

# **HALL EFFECT SENSING AND APPLICATION**



# Table of Contents

## Chapter 1 • Hall Effect Sensing

- Introduction ..... 1
- Hall Effect Sensors ..... 1
- Why use the Hall Effect ..... 2
- Using this Manual ..... 2

## Chapter 2 • Hall Effect Sensors

- Introduction ..... 3
- Theory of the Hall Effect ..... 3
- Basic Hall effect sensors ..... 4
- Analog output sensors ..... 5
- Output vs. power supply characteristics ..... 5
- Transfer Function ..... 6
- Digital output sensors ..... 7
- Transfer Function ..... 7
- Power Supply Characteristics ..... 8
  - Input Characteristics ..... 8
  - Output Characteristics ..... 8
- Summary ..... 8

## Chapter 3 • Magnetic Considerations

- Magnetic Fields ..... 9
- Magnetic materials and their specifications ..... 9
- Basic magnetic design considerations ..... 10
- Magnetic materials summary ..... 11
- Magnetic systems ..... 11
- Unipolar head-on mode ..... 12
- Unipolar slide-by mode ..... 12
- Bipolar slide-by mode ..... 13
  - Bipolar slide by mode (ring magnet) ..... 14
  - Systems with pole pieces ..... 15
  - Systems with bias magnets ..... 16
- Magnetic systems comparison ..... 17
- Ratiometric Linear Hall effect sensors ..... 18
- Summary ..... 18

## Chapter 4 • Electrical Considerations

Introduction .....	19
Digital output sensors.....	19
Electrical specifications .....	20
Specification definitions.....	20
Absolute Maximum Ratings.....	20
Rated Electrical Characteristics .....	21
Basic interfaces.....	21
Pull-up resistors .....	21
Logic gate interfaces.....	22
Transistor interfaces .....	22
Symbols for design calculations .....	24
Analog Output Sensors .....	29
Electrical specifications .....	30
Basic interfaces.....	30
Interfaces to common components .....	31
Summary.....	32

## Chapter 5 • Hall-based Sensing Devices

Introduction .....	33
Vane-operated position sensors.....	33
Principles of Operation.....	33
Sensor Specifications.....	35
Digital current sensors.....	36
Principles of Operation.....	37
Sensor Specifications.....	37
Linear current sensors.....	38
Principles of Operation.....	38
C.losed Loop Current Sensors .....	39
Principles of Operation.....	39
Mechanically operated solid state switches.....	41
Principles of Operation.....	41
Switch specifications .....	42
Gear Tooth Sensors .....	42
Principles of Operation.....	43
Target Design.....	43
Summary.....	44

## Chapter 6 • Applying Hall-effect Sensing Devices

General sensing device design .....	45
Design of Hall effect-based sensing devices .....	47
System definition.....	48
Concept definition... Discrete sensing devices .....	48
Digital output Hall effect-based sensing devices .....	49
Design approach... Non-precision applications .....	49
Design Approach... Precision applications.....	51
Linear output Hall effect-based sensing devices .....	53

Design approach... Linear output sensors .....	53
Design approach... Linear current sensors .....	55
Sensor packages.....	57
Design approach... Vane-operated sensors .....	58
Design approach... Digital output current sensor.....	59
Summary.....	60

## Chapter 7 • Application Examples

Flow rate sensor (digital) .....	63
Sequencing sensors.....	63
Proximity sensors .....	64
Office machine sensors.....	64
Adjustable current sensor.....	65
Linear feedback sensor .....	66
Multiple position sensor.....	66
Microprocessor controlled sensor.....	67
Anti-skid sensor.....	67
Door interlock and ignition sensor.....	67
Transmission mounted speed sensor.....	68
Crankshaft position or speed sensor .....	68
Distributor mounted ignition sensor .....	68
Level/tilt measurement sensor.....	69
Brushless DC motor sensors .....	69
RPM sensors.....	70
Remote conveyor sensing .....	70
Remote reading sensing.....	71
Current sensors.....	71
Flow rate sensor (linear output .....	72
Piston detection sensor .....	73
Temperature or pressure sensor .....	73
Magnetic card reader.....	74
Throttle angle sensor.....	75
Automotive sensors.....	76

<b>Appendix A • Units and Conversion Factors.....</b>	<b>77</b>
---	-----------

<b>Appendix B • Magnet Application Data.....</b>	<b>79</b>
--	-----------

<b>Appendix C • Magnetic Curves.....</b>	<b>89</b>
--	-----------

<b>Appendix D • Use of Calibrated Hall Device.....</b>	<b>99</b>
--	-----------

<b>Glossary.....</b>	<b>103</b>
----------------------	------------



# Chapter 1

# Hall Effect Sensing

## Introduction

The Hall effect has been known for over one hundred years, but has only been put to noticeable use in the last three decades. The first practical application (outside of laboratory experiments) was in the 1950s as a microwave power sensor. With the mass production of semiconductors, it became feasible to use the Hall effect in high volume products. MICRO SWITCH Sensing and Control revolutionized the keyboard industry in 1968 by introducing the first solid state keyboard using the Hall effect. For the first time, a Hall effect sensing element and its associated electronics were combined in a single integrated circuit. Today, Hall effect devices are included in many products, ranging from computers to sewing machines, automobiles to aircraft, and machine tools to medical equipment.

## Hall effect sensors

The Hall effect is an ideal sensing technology. The Hall element is constructed from a thin sheet of conductive material with output connections perpendicular to the direction of current flow. When subjected to a magnetic field, it responds with an output voltage proportional to the magnetic field strength. The voltage output is very small ( $\mu\text{V}$ ) and requires additional electronics to achieve useful voltage levels. When the Hall element is combined with the associated electronics, it forms a Hall effect sensor. The heart of every MICRO SWITCH Hall effect device is the integrated circuit chip that contains the Hall element and the signal conditioning electronics.

Although the Hall effect sensor is a magnetic field sensor, it can be used as the principle component in many other types of sensing devices (current, temperature, pressure, position, etc.).

Hall effect sensors can be applied in many types of sensing devices. If the quantity (parameter) to be sensed incorporates or can incorporate a magnetic field, a Hall sensor will perform the task. Figure 1-1 shows a block diagram of a sensing device that uses the Hall effect.

In this generalized sensing device, the Hall sensor senses the field produced by the magnetic system. The magnetic system responds to the physical quantity to be sensed (temperature, pressure, position, etc.) through the input interface. The output interface converts the electrical signal from the Hall sensor to a signal that meets the requirements of the application. The four blocks contained within the sensing device (Figure 1-1) will be examined in detail in the following chapters.

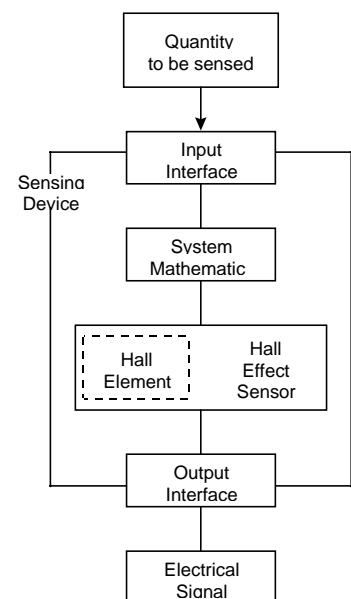

**Figure 1-1 General sensor based on the Hall effect**

### Why use the Hall effect?

The reasons for using a particular technology or sensor vary according to the application. Cost, performance and availability are always considerations. The features and benefits of a given technology are factors that should be weighed along with the specific requirements of the application in making this decision.

General features of Hall effect based sensing devices are:

- True solid state
- Long life (30 billion operations in a continuing keyboard module test program)
- High speed operation - over 100 kHz possible
- Operates with stationary input (zero speed)
- No moving parts
- Logic compatible input and output
- Broad temperature range (-40 to +150°C)
- Highly repeatable operation

### Using this manual

This manual may be considered as two parts: Chapters 2 through 5 present the basic information needed to apply Hall effect devices. Chapter 6 brings this information together and relates it to the design and application of the Hall effect sensing systems.

**Chapter 2, Hall effect sensors.** Introduces the theory of operation and relates it to the Hall effect sensors. Both digital and analog sensors are discussed and their characteristics are examined. This chapter describes what a Hall effect sensor is and how it is specified.

**Chapter 3, Magnetic considerations.** Covers magnetism and magnets as they relate to the input of a Hall effect device. Various magnetic systems for actuating a sensor are examined in detail.

**Chapter 4, Electrical considerations.** Discusses the output of a Hall effect device. Electrical specifications as well as various interface circuits are examined. These three chapters (2, 3, and 4) provide the nucleus for applying Hall effect technology.

**Chapter 5, Sensing devices based on the Hall effect.** These devices combine both a magnetic system and a Hall effect sensor into a single package. The chapter includes vane operated position sensors, current sensors, gear tooth sensors and magnetically-operated solid state switches. The principles of operation and how these sensors are specified are examined.

**Chapter 6, Applying Hall effect sensors.** This chapter presents procedures that take the designer from an objective (to sense some physical parameter) through detailed sensor design. This chapter brings together the Hall sensor (Chapter 2), its input (Chapter 3), and its output (Chapter 4).

**Chapter 7, Application concepts.** This is an idea chapter. It presents a number of ways to use Hall effect sensors to perform a sensing function. This chapter cannot by its nature be all inclusive, but should stimulate ideas on the many additional ways Hall effect technology can be applied.

This manual may be used in a number of ways. For a complete background regarding the application of Hall effect sensors, start with Chapter 1 and read straight through. If a sensing application exists and to determine the applicability of the Hall effect, Chapter 7 might be a good place to start. If a concept exists and the designer is familiar with Hall effect sensors, start with Chapter 6 and refer back to various chapters as the need arises.



# Chapter 2

# Hall Effect Sensors

## Introduction

The Hall effect was discovered by Dr. Edwin Hall in 1879 while he was a doctoral candidate at Johns Hopkins University in Baltimore. Hall was attempting to verify the theory of electron flow proposed by Kelvin some 30 years earlier. Dr. Hall found when a magnet was placed so that its field was perpendicular to one face of a thin rectangle of gold through which current was flowing, a difference in potential appeared at the opposite edges. He found that this voltage was proportional to the current flowing through the conductor, and the flux density or magnetic induction perpendicular to the conductor. Although Hall's experiments were successful and well received at the time, no applications outside of the realm of theoretical physics were found for over 70 years.

With the advent of semiconducting materials in the 1950s, the Hall effect found its first applications. However, these were severely limited by cost. In 1965, Everett Vorthmann and Joe Maupin, MICRO SWITCH Sensing and Control senior development engineers, teamed up to find a practical, low-cost solid state sensor. Many different concepts were examined, but they chose the Hall effect for one basic reason: it could be entirely integrated on a single silicon chip. This breakthrough resulted in the first low-cost, high-volume application of the Hall effect, truly solid state keyboards. MICRO SWITCH Sensing and Control has produced and delivered nearly a billion Hall effect devices in keyboards and sensor products.

## Theory of the Hall Effect

When a current-carrying conductor is placed into a magnetic field, a voltage will be generated perpendicular to both the current and the field. This principle is known as the Hall effect.

Figure 2-1 illustrates the basic principle of the Hall effect. It shows a thin sheet of semiconducting material (Hall element) through which a current is passed. The output connections are perpendicular to the direction of current. When no magnetic field is present (Figure 2-1), current distribution is uniform and no potential difference is seen across the output.

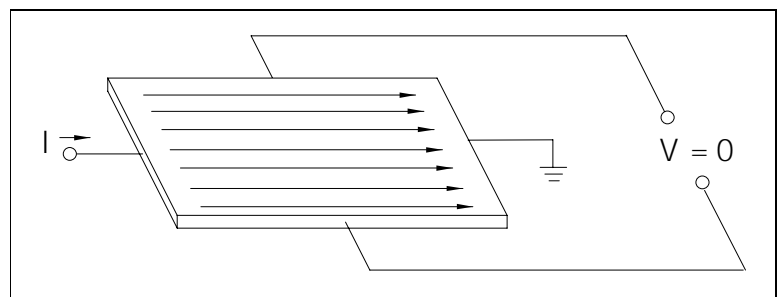

Figure 2-1 Hall effect principle, no magnetic field

When a perpendicular magnetic field is present, as shown in Figure 2-2, a Lorentz force is exerted on the current. This force disturbs the current distribution, resulting in a potential difference (voltage) across the output. This voltage is the Hall voltage ( $V_H$ ). The interaction of the magnetic field and the current is shown in equation form as equation 2-1.

$$V_H \propto \mathbf{I} \times \mathbf{B}$$

Formula (2-1)

Hall effect sensors can be applied in many types of sensing devices. If the quantity (parameter) to be sensed incorporates or can incorporate a magnetic field, a Hall sensor will perform the task.

## Chapter 2 • Hall Effect Sensors

The Hall voltage is proportional to the vector cross product of the current ( $I$ ) and the magnetic field ( $B$ ). It is on the order of  $7 \mu\text{v}/\text{V}_s/\text{gauss}$  in silicon and thus requires amplification for practical applications.

Silicon exhibits the piezoresistance effect, a change in electrical resistance proportional to strain. It is desirable to minimize this effect in a Hall sensor. This is accomplished by orienting the Hall element on the IC to minimize the effect of stress and by using multiple Hall elements. Figure 2-3 shows two Hall elements located in close proximity on an IC. They are positioned in this manner so that they may both experience the same packaging stress, represented by  $\Delta R$ . The first Hall element has its excitation applied along the vertical axis and the second along the horizontal axis. Summing the two outputs eliminates the signal due to stress. MICRO SWITCH Hall ICs use two or four elements.

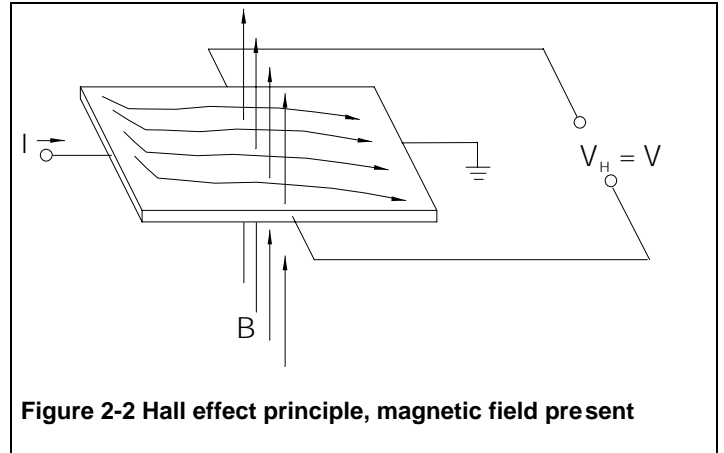

Figure 2-2 Hall effect principle, magnetic field present

### Basic Hall effect sensors

The Hall element is the basic magnetic field sensor. It requires signal conditioning to make the output usable for most applications. The signal conditioning electronics needed are an amplifier stage and temperature compensation. Voltage regulation is needed when operating from an unregulated supply. Figure 2-4 illustrates a basic Hall effect sensor.

If the Hall voltage is measured when no magnetic field is present, the output is zero (see Figure 2-1). However, if voltage at each output terminal is measured with respect to ground, a non-zero voltage will appear. This is the common mode voltage (CMV), and is the same at each output terminal. It is the potential difference that is zero. The amplifier shown in Figure 2-4 must be a differential amplifier so as to amplify only the potential difference – the Hall voltage.

The Hall voltage is a low-level signal on the order of 30 microvolts in the presence of a one gauss magnetic field. This low-level output requires an amplifier with low noise, high input impedance and moderate gain.

A differential amplifier with these characteristics can be readily integrated with the Hall element using standard bipolar transistor technology. Temperature compensation is also easily integrated.

As was shown by equation 2-1, the Hall voltage is a function of the input current. The purpose of the regulator in Figure 2-4 is to hold this current constant so that the output of the sensor only reflects the intensity of the magnetic field. As many systems have a regulated supply available, some Hall effect sensors may not include an internal regulator.

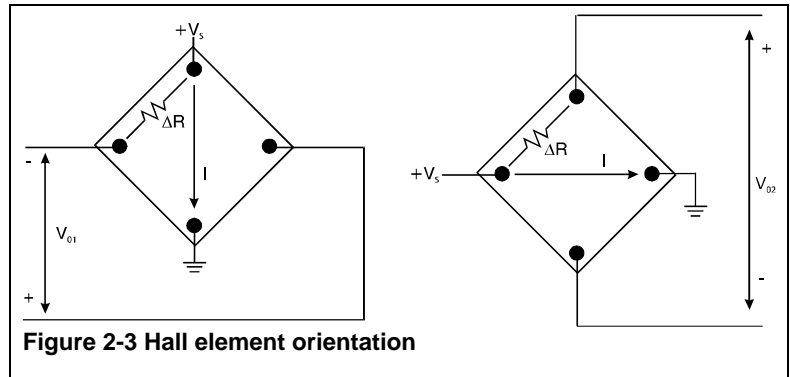

Figure 2-3 Hall element orientation

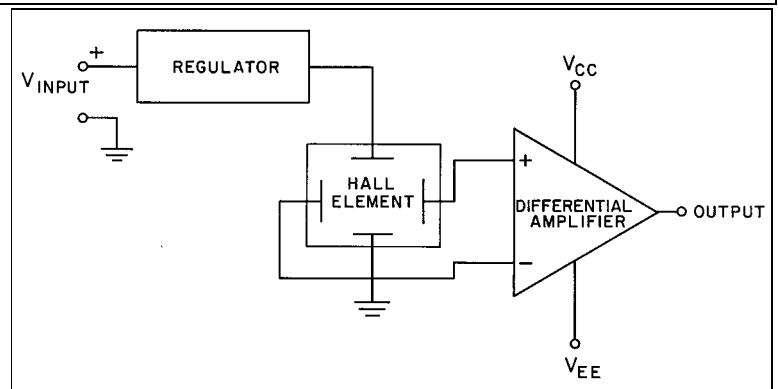

Figure 2-4 Basic Hall effect sensor

### Analog output sensors

The sensor described in Figure 2-4 is a basic analog output device. Analog sensors provide an output voltage that is proportional to the magnetic field to which it is exposed. Although this is a complete device, additional circuit functions were added to simplify the application.

The sensed magnetic field can be either positive or negative. As a result, the output of the amplifier will be driven either positive or negative, thus requiring both plus and minus power supplies. To avoid the requirement for two power supplies, a fixed offset or bias is introduced into the differential amplifier. The bias value appears on the output when no magnetic field is present and is referred to as a null voltage. When a positive magnetic field is sensed, the output increases above the null voltage. Conversely, when a negative magnetic field is sensed, the output decreases below the null voltage, but remains positive. This concept is illustrated in Figure 2-5.

The output of the amplifier cannot exceed the limits imposed by the power supply. In fact, the amplifier will begin to saturate before the limits of the power supply are reached. This saturation is illustrated in Figure 2-5. It is important to note that this saturation takes place in the amplifier and not in the Hall element. Thus, large magnetic fields will not damage the Hall effect sensors, but rather drive them into saturation.

To further increase the interface flexibility of the device, an open emitter, open collector, or push-pull transistor is added to the output of the differential amplifier. Figure 2-6 shows a complete analog output Hall effect sensor incorporating all of the previously discussed circuit functions.

The basic concepts pertaining to analog output sensors have been established. Both the manner in which these devices are specified and the implication of the specifications follow.

### Output vs. power supply characteristics

Analog output sensors are available in voltage ranges of 4.5 to 10.5, 4.5 to 12, or 6.6 to 12.6 VDC. They typically require a regulated supply voltage to operate accurately. Their output is usually of the push-pull type and is ratiometric to the supply voltage with respect to offset and gain.

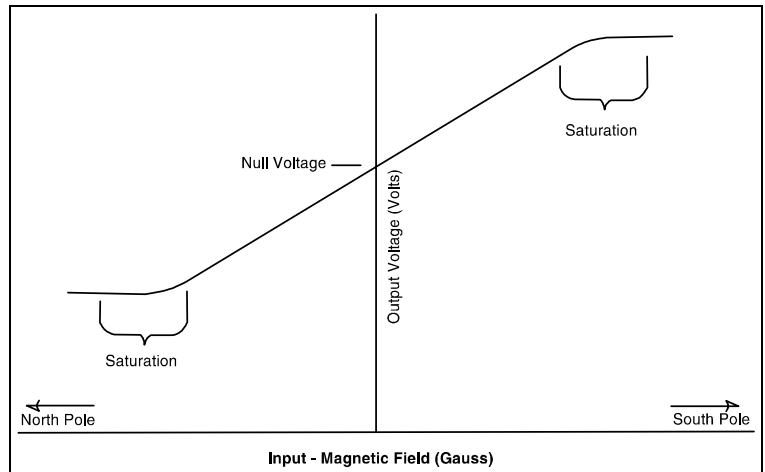

Figure 2-5 Null voltage concept

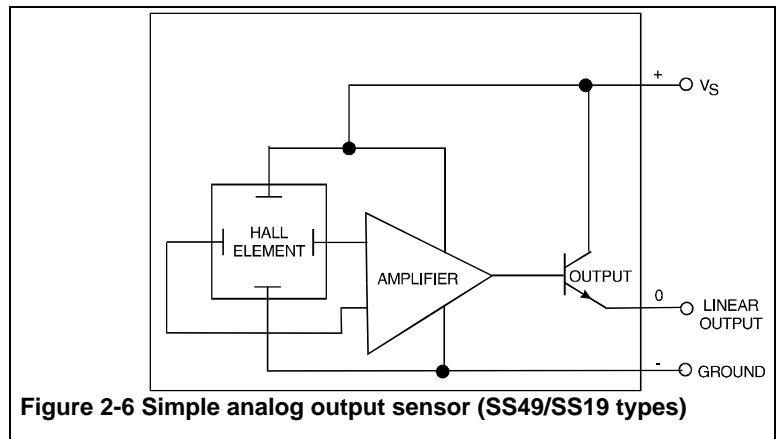

Figure 2-6 Simple analog output sensor (SS49/SS19 types)

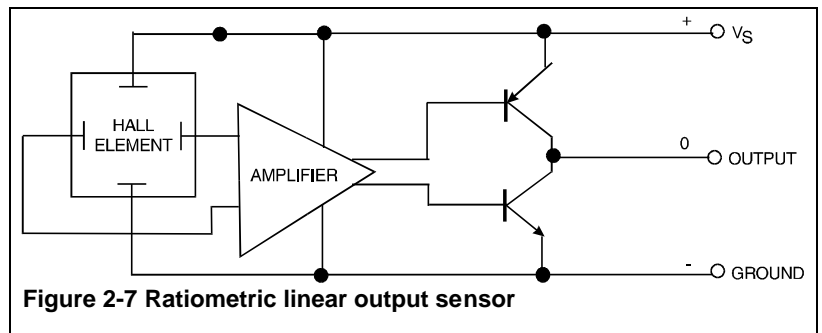

Figure 2-7 Ratiometric linear output sensor

## Chapter 2 • Hall Effect Sensors

Figure 2-7 illustrates a ratiometric analog sensor that accepts a 4.5 to 10.5 V supply. This sensor has a sensitivity (mV/Gauss) and offset (V) proportional (ratiometric) to the supply voltage. This device has “rail-to-rail” operation. That is, its output varies from almost zero (0.2 V typical) to almost the supply voltage ( $V_s - 0.2$  V typical).

### Transfer Function

The transfer function of a device describes its output in terms of its input. The transfer function can be expressed in terms of either an equation or a graph. For analog output Hall effect sensors, the transfer function expresses the relationship between a magnetic field input (gauss) and a voltage output. The transfer function for a typical analog output sensor is illustrated in Figure 2-8.

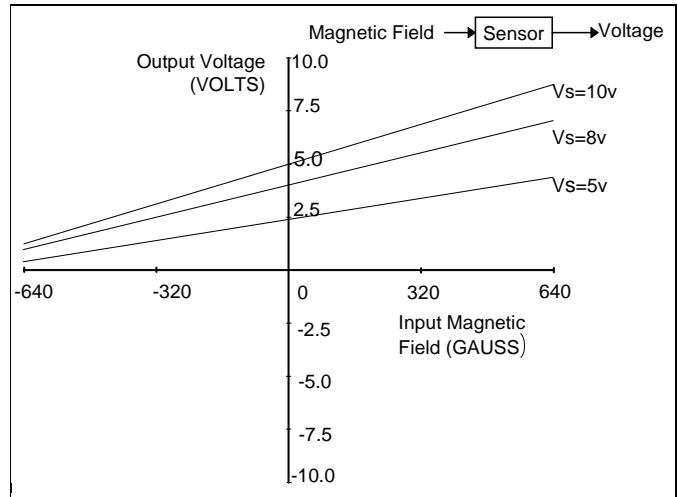

Figure 2-8 Transfer function . . . Analog output sensor

Equation 2-2 is an analog approximation of the transfer function for the sensor.

$$V_{out} \text{ (Volts)} = (6.25 \times 10^{-4} \times V_s)B + (0.5 \times V_s) \quad (2-2)$$

$$-640 < B(\text{Gauss}) < +640$$

An analog output sensor’s transfer function is characterized by sensitivity, null offset and span.

Sensitivity is defined as the change in output resulting from a given change in input. The slope of the transfer function illustrated in Figure 2-8 corresponds to the sensitivity of the sensor. The factor of  $\{B (6.25 \times 10^{-4} \times V_s)\}$  in equation 2-2 expresses the sensitivity for this sensor.

Null offset is the output from a sensor with no magnetic field excitation. In the case of the transfer function in Figure 2-8, null offset is the output voltage at 0 gauss and a given supply voltage. The second term in Equation 2-2,  $(0.5 \times V_s)$ , expresses the null offset.

Span defines the output range of an analog output sensor. Span is the difference in output voltages when the input is varied from negative gauss (north) to positive gauss (south). In equation form:

$$\text{Span} = V_{OUT} @ (+) \text{ gauss} - V_{OUT} @ (-) \text{ gauss} \quad (2-3)$$

Although an analog output sensor is considered to be linear over its span, in practice, no sensor is perfectly linear. The specification linearity defines the maximum error that results from assuming the transfer function is a straight line. Honeywell’s analog output Hall effect sensors are precision sensors typically exhibiting linearity specified as -0.5% to -1.5% (depending on the listing). For these devices, linearity is measured as the difference between actual output and the perfect straight line between end points. It is given as a percentage of the span.

The basic Hall device is sensitive to variations in temperature. Signal conditioning electronics may be incorporated into Hall effect sensors to compensate for these effects. Figure 2-9 illustrates the sensitivity shift over temperature for the miniature ratiometric linear Hall effect sensor.

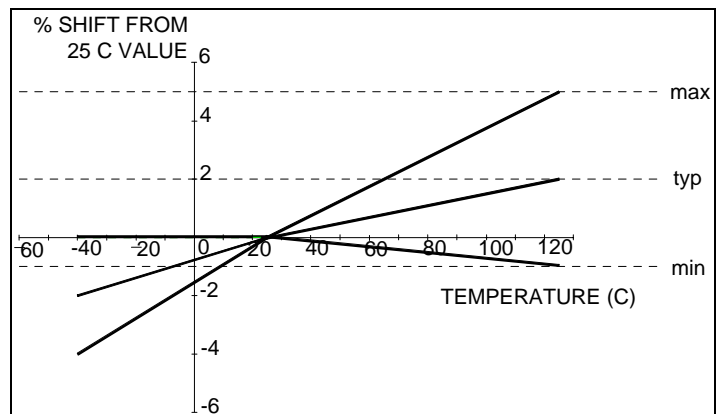

Figure 2-9 Sensitivity shift versus temperature

### Digital output sensors

The preceding discussion described an analog output sensor as a device having an analog output proportional to its input. In this section, the digital Hall effect sensor will be examined. This sensor has an output that is just one of two states: ON or OFF. The basic analog output device illustrated in Figure 2-4 can be converted into a digital output sensor with the addition of a Schmitt trigger circuit. Figure 2-10 illustrates a typical internally regulated digital output Hall effect sensor.

The Schmitt trigger compares the output of the differential amplifier (Figure 2-10) with a preset reference. When the amplifier output exceeds the reference, the Schmitt trigger turns on. Conversely, when the output of the amplifier falls below the reference point, the output of the Schmitt trigger turns off.

Hysteresis is included in the Schmitt trigger circuit for jitter-free switching. Hysteresis results from two distinct reference values which depend on whether the sensor is being turned ON or OFF.

### Transfer function

The transfer function for a digital output Hall effect sensor incorporating hysteresis is shown in Figure 2-11.

The principal input/output characteristics are the operate point, release point and the difference between the two or differential. As the magnetic field is increased, no change in the sensor output will occur until the operate point is reached. Once the operate point is reached, the sensor will change state. Further increases in magnetic input beyond the operate point will have no effect. If magnetic field is decreased to below the operate point, the output will remain the same until the release point is reached. At this point, the sensor's output will return to its original state (OFF). The purpose of the differential between the operate and release point (hysteresis) is to eliminate false triggering which can be caused by minor variations in input.

As with analog output Hall effect sensors, an output transistor is added to increase application flexibility. This output transistor is typically NPN (current sinking). See Figure 2-12. The features and benefits are examined in detail in Chapter 4.

The fundamental characteristics relating to digital output sensors have been presented. The specifications and the effect these specifications have on product selection follows.

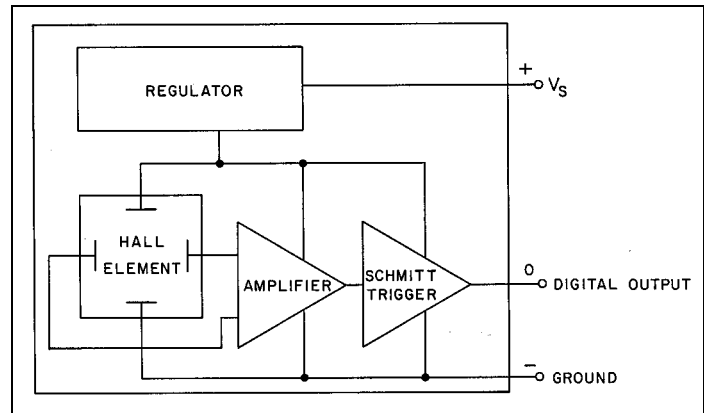

Figure 2-10 Digital output Hall effect sensor

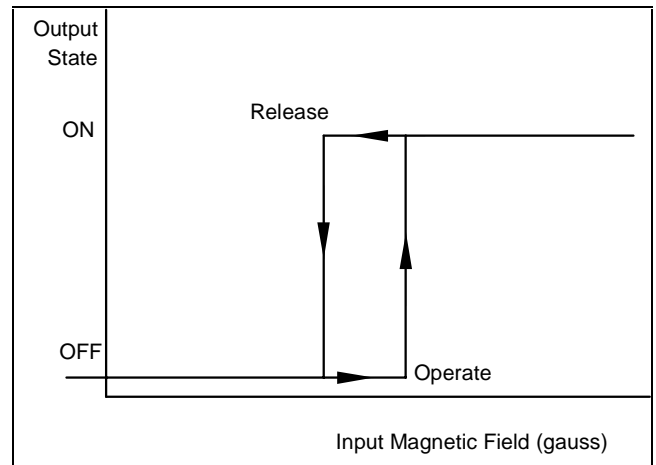

Figure 2-11 Transfer function hysteresis . . . Digital output sensor

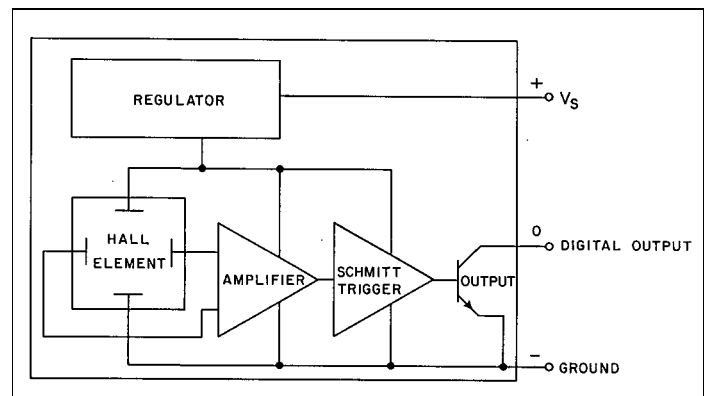

Figure 2-12 NPN (Current sinking) . . . Digital output sensor

**Power supply characteristics**

Digital output sensors are available in two different power supply configurations - regulated and unregulated. Most digital Hall effect sensors are regulated and can be used with power supplies in the range of 3.8 to 24 VDC. Unregulated sensors are used in special applications. They require a regulated DC supply of 4.5 to 5.5 volts ( $5 \pm 0.5$  v). Sensors that incorporate internal regulators are intended for general purpose applications. Unregulated sensors should be used in conjunction with logic circuits where a regulated 5 volt power supply is available.

**Input characteristics**

The input characteristics of a digital output sensor are defined in terms of an operate point, release point, and differential. Since these characteristics change over temperature and from sensor to sensor, they are specified in terms of maximum and minimum values.

Maximum Operate Point refers to the level of magnetic field that will insure the digital output sensor turns ON under any rated condition. Minimum Release Point refers to the level of magnetic field that insures the sensor is turned OFF.

Figure 2-13 shows the input characteristics for a typical unipolar digital output sensor. The sensor shown is referred to as unipolar since both the maximum operate and minimum release points are positive (i.e. south pole of magnetic field).

A bipolar sensor has a positive maximum operate point (south pole) and a negative minimum release point (north pole). The transfer functions are illustrated in Figure 2-14. Note that there are three combinations of actual operate and release points possible with a bipolar sensor. A true latching device, represented as bipolar device 2, will always have a positive operate point and a negative release point.

**Output characteristics**

The output characteristics of a digital output sensor are defined as the electrical characteristics of the output transistor. These include type (i.e. NPN), maximum current, breakdown voltage, and switching time. The implication of this and other parameters will be examined in depth in Chapter 4.

**Summary**

In this chapter, basic concepts pertaining to Hall effect sensors were presented. Both the theory of the Hall effect and the operation and specifications of analog and digital output sensors were examined. In the next chapter, the principles of magnetism will be presented. This information will form the foundation necessary to design magnetic systems that actuate Hall effect sensors.

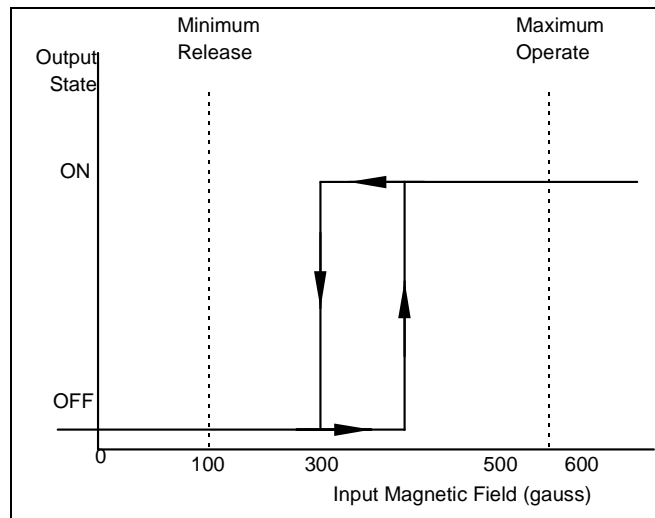

**Figure 2-13 Unipolar input characteristics . . . Digital output sensor**

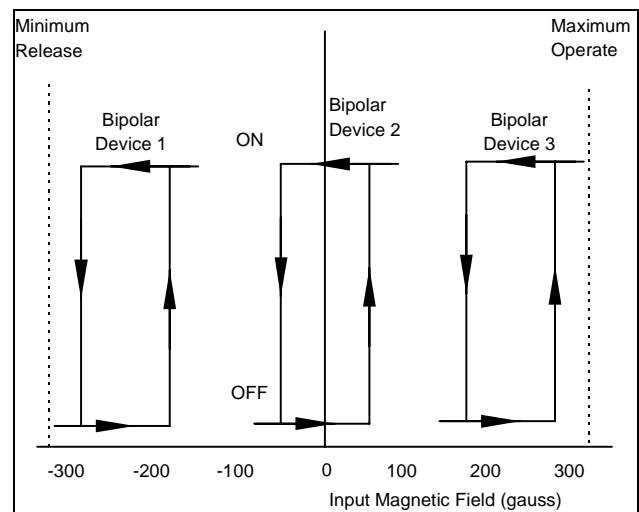

**Figure 2-14 Bipolar input characteristics . . . Digital output sensor**

# Magnetic Considerations

## Magnetic fields

The space surrounding a magnet is said to contain a magnetic field. It is difficult to grasp the significance of this strange condition external to the body of a permanent magnet. It is a condition undetected by any of the five senses. It cannot be seen, felt or heard, nor can one taste or smell it. Yet, it exists and has many powers. It can attract ferromagnetic objects, convert electrical energy to mechanical energy and provide the input for Hall effect sensing devices. This physical force exerted by a magnet can be described as lines of flux originating at the north pole of a magnet and terminating at its south pole (Figure 3-1). As a result, lines of flux are said to have a specific direction.

The concept of flux density is used to describe the intensity of the magnetic field at a particular point in space. Flux density is used as the measure of magnetic field. Units of flux density include teslas and webers/meter<sup>2</sup>. The CGS unit of magnetic field, **gauss**, is the unit used throughout this book. For conversion factors, see Appendix A.

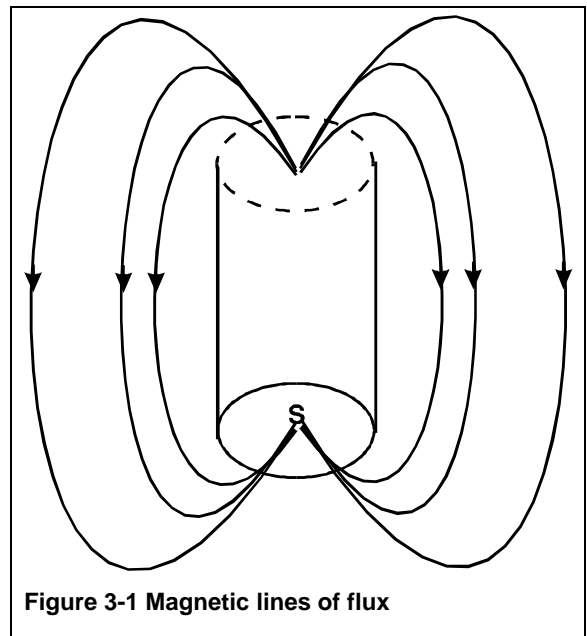

Figure 3-1 Magnetic lines of flux

## Magnetic materials and their specifications

As opposed to sophisticated magnet theory (of principal importance to magnet manufacturers), practical magnet specification involves only a basic understanding of magnetic materials (refer to Appendix B) and those characteristics that affect the field produced by a magnet.

The starting point in understanding magnetic characteristics is the magnetization curve as illustrated in Figure 3-2.

This curve describes the characteristics of a magnetic material. The horizontal axis corresponds to the magnetizing force (H) expressed in oersteds. The vertical axis corresponds to flux density (B) expressed in gauss. The first quadrant of this curve shows the characteristics of a material while being magnetized. When an unmagnetized material ( $B = 0, H = 0$ ) is subjected to a gradually increasing magnetizing force, the flux density in the material increases from 0 to  $B_{MAX}$ . At this point, the material is magnetically saturated and can be magnetized no further.

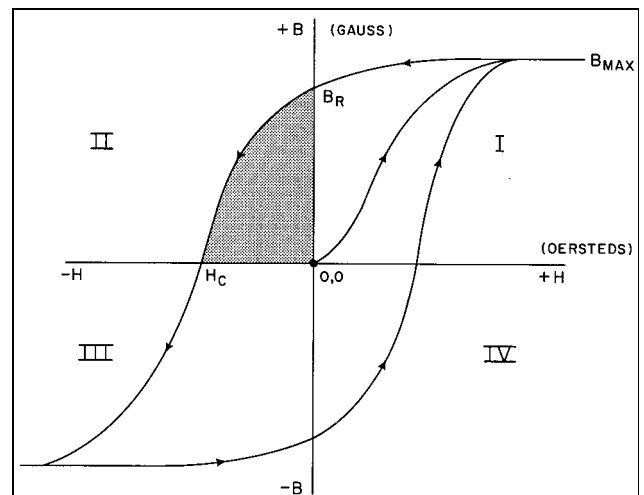

Figure 3-2 Magnetization curve

## Chapter 3 • Magnetic Considerations

If the magnetizing force is then gradually reduced to 0, the flux density does not retrace the original magnetizing curve. Rather, the flux density of the material decreases to a point known as the Residual Induction ( $B_R$ ).

If the magnetizing force is reversed in direction and increased in value, the flux density in the material is further reduced, and it becomes zero when the demagnetizing force reaches a value of  $H_C$ , known as the Coercive Force.

The second quadrant of the magnetization curve, shown shaded, is of primary interest to the designers of permanent magnets. This quadrant is known as the Demagnetization Curve, and is shown in Figure 3-3 along with the Energy Product Curve.

The energy product curve is derived from the demagnetization curve by taking a product of  $B$  and  $H$  for every point, and plotting it against  $B$ . Points on the energy product curve represent external energy produced per unit of volume. This external energy has a peak value known as the Peak Energy Product ( $B_D H_{D(MAX)}$ ). The peak energy product value is used as the criterion for comparing one magnetic material with another. Appendix B contains comparative information on various magnet materials.

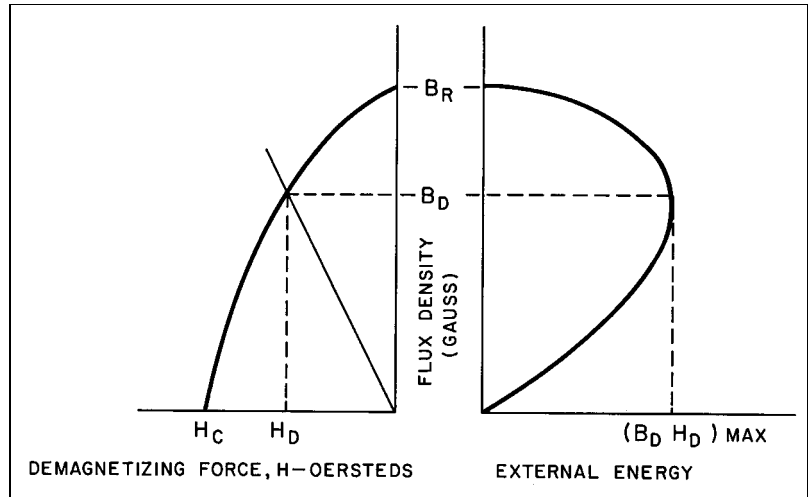

Figure 3-3 Demagnetization and energy product curve

### Basic magnetic design considerations

The flux density produced by a magnet at a particular point in space is affected by numerous factors. Among these are magnet length, cross sectional area, shape and material as well as other substances in the path of the flux. Consequently, a complete discussion of magnet design procedures is beyond the scope of this book. It is, however, important to understand the influence of these factors when applying Hall effect sensors.

When choosing a magnet to provide a particular flux density at a given point in space, it is necessary that the entire magnetic circuit be considered. The magnetic circuit may be divided into two parts; the magnet itself, and the path flux takes in getting from one pole of the magnet to the other.

First consider the magnet by itself. For a given material, there is a corresponding demagnetization curve such as the one in Figure 3-4.  $B_R$  represents the peak flux density available from this material. For a magnet with a given geometry, the flux density will be less than  $B_R$  and will depend on the ratio  $B/H$ , known as the permeance. Load line 1 in Figure 3-4 represents a fixed value of permeance. The point at which it crosses the demagnetization curve determines the peak flux density available from this magnet.

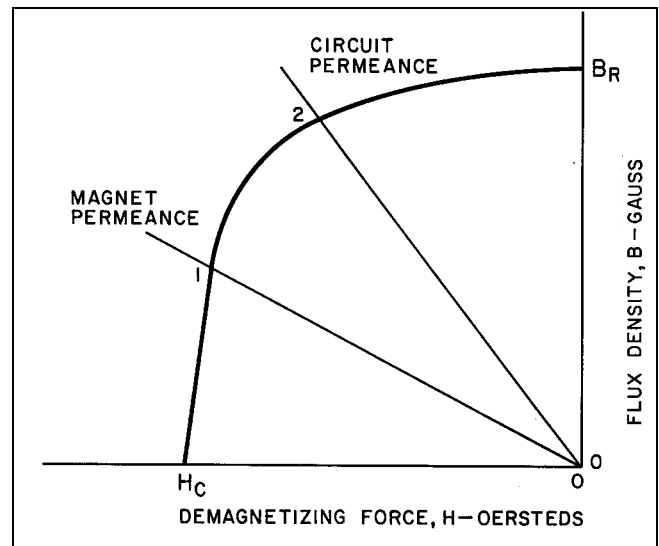

Figure 3-4 Typical magnet material load lines



The field at a point **P** some distance **d** from the North pole face of a magnet is proportional to the inverse square of the distance. This is shown in equation form by equation 3-1 and graphically by Figure 3-5.

$$B_N \propto 1/d^2 \tag{3-1}$$

The field indicated by equation 3-1 is reduced by the action of the South pole at the rear of the magnet which is stated in equation 3-2.

$$B_S \propto 1/(d+L)^2 \tag{3-2}$$

This means that magnetic sensing is only effective at short distances. It also means that a magnet of a given pole face area will exhibit increasing field strength with length per the above relation. The field strength at point **P** is also roughly proportional to the area of the pole face.

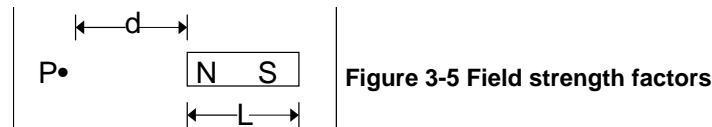

The magnet considered by itself corresponds to an open circuit condition, where permeance is strictly a function of magnet geometry. If the magnet is assembled into a circuit where magnetically soft materials (pole pieces) direct the flux path, geometry of the magnet is only one consideration. Since permeance is a measure of the ease with which flux can get from one pole to the other, it follows that permeance may be increased by providing a “lower resistance path.” This concept is illustrated by load line 2 in Figure 3-4 which represents the permeance of the circuit with the addition of pole pieces. The point at which the load line now crosses the demagnetization curve shows a peak flux density greater than that of the magnet alone. Since some applications of Hall effect sensors call for magnetic systems that include soft magnetic materials (pole pieces or flux concentrators) it is important to consider the permeance of the entire magnetic system.

### Magnet materials summary

The materials commonly used for permanent magnets and their properties are contained in Appendix B. The table in Figure 3-6 provides a relative comparison between various magnet materials. The list of materials presented is not intended to be exhaustive,

Class of Material	Relative Properties		(BDHD)MAX	Relative Cost	Stability	BR TC (%/°C)
	BR	HC				
Alnico	High	Low	Med.	High	medium	-0.02
INDOX®	Low	High	Low to Med.	Low	high	-0.2
Ferrite	Medium	Medium	Medium	Low	high	-0.04
Rare Earth	High	Highest	Highest	Highest	high	-0.12
NdFeB	High	High	High	Medium	High	-0.12

Figure 3-6 Magnet material comparison chart

but rather to be representative of those commonly available. The remainder of this chapter is devoted to an examination of the relation between the position of a magnet and the flux density at a point where a Hall effect sensor will be located.

### Magnetic systems

Hall effect sensors convert a magnetic field to a useful electrical signal. In general, however, physical quantities (position, speed, temperature, etc.) other than a magnetic field

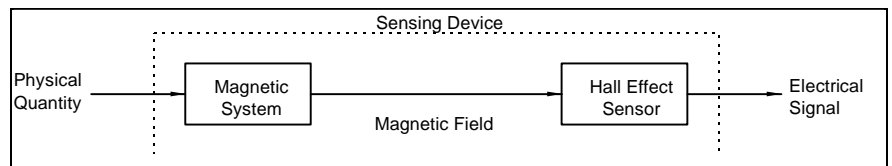

Figure 3-7 General Hall effect system

are sensed. The magnetic system performs the function of changing this physical quantity to a magnetic field which can in turn be sensed by Hall effect sensors. The block diagram in Figure 3-7 illustrates this concept.

## Chapter 3 • Magnetic Considerations

Many physical parameters can be measured by inducing motion of a magnet. For example, both temperature and pressure can be sensed through the expansion and contraction of a bellows to which a magnet is attached. Refer to Chapter 6 for an example of a Hall effect-based temperature sensor that makes use of a bellows.

The gauss versus distance curves which follow give the general shape of this relation. Actual curves will require making the measurements for a particular magnet. Refer to Appendix C for curves of various magnets.

### Unipolar head-on mode

Figure 3-8 shows the Unipolar Head-on Mode of actuating a Hall effect sensor. The term “head-on” refers to the manner in which the magnet moves relative to the sensor’s reference point. In this case, the magnet’s direction of movement is directly toward and away from the sensor, with the magnetic lines of flux passing through the sensor’s reference point. The magnet and sensor are positioned so the south pole of the magnet will approach the sensing face of the Hall effect sensor.

Flux lines are a vector quantity with a specific direction (from the magnet’s north pole to its south pole). Flux density is said to have a positive polarity if its direction is the same as the sensor’s reference direction. The arrow in Figure 3-8 defines this reference direction. In the mode shown, only lines of flux in the reference direction (positive) are detected. As a result, this mode is known as unipolar.

In the unipolar head-on mode, the relation between gauss and distance is given by the inverse square law. Distance is measured from the face of the sensor to the south pole of the magnet, along the direction of motion.

To demonstrate application of this magnetic curve, assume a digital (ON/OFF) Hall effect sensor is used. For this example, the sensor will have an operate (ON) level of  $G_1$  and a release (OFF) level of  $G_2$ . As the magnet moves toward the sensor it will reach a point  $D_1$ , where the flux density will be great enough to turn the sensor ON. The motion of the magnet may then be reversed and moved to a point  $D_2$  where the magnetic field is reduced sufficiently to return the sensor to the OFF state. Note that the unipolar head-on mode requires a reciprocating magnet movement.

Actual graphs of various magnets (gauss versus distance) are shown in Appendix C.

### Unipolar slide-by mode

In the Unipolar Slide-by Mode shown in Figure 3-9, a magnet is moved in a horizontal plane beneath the sensor’s sensing face. If a second horizontal plane is drawn through the sensor, the distance between these two places is referred to as the gap. Distance in this

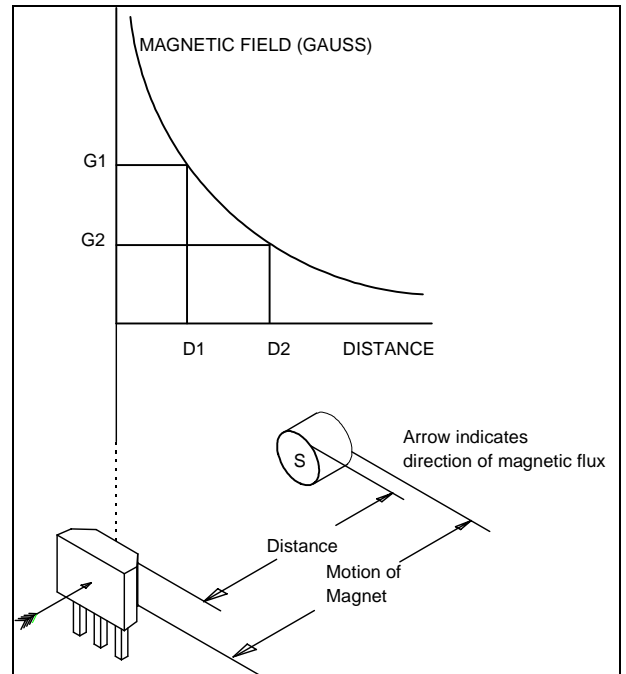

Figure 3-8 Unipolar head-on mode

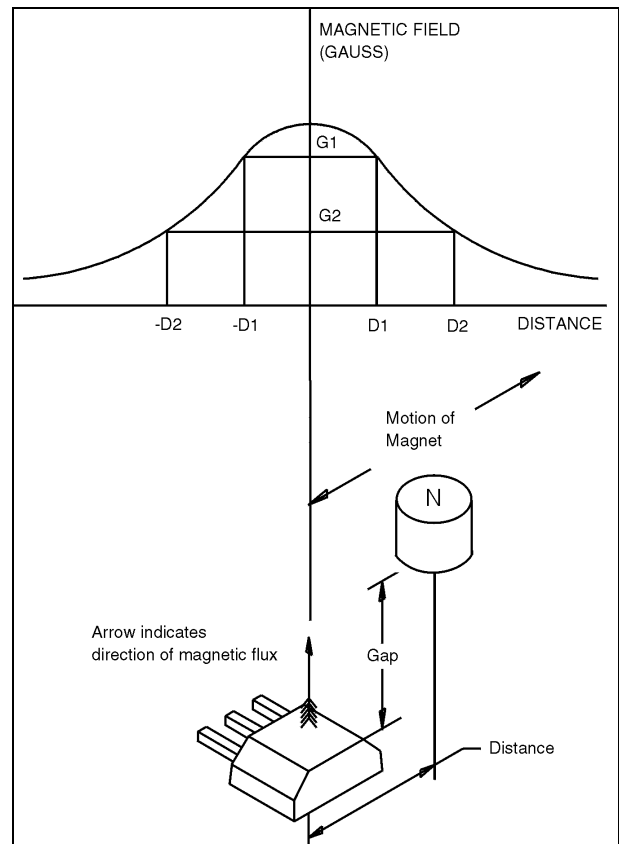

Figure 3-9 Unipolar slide-by mode

mode is measured relative to the center of the magnet's pole face and the sensor's reference point in the horizontal plane of the magnet.

The gauss versus distance relation in this mode is a bell shaped curve. The peak (maximum gauss) of the curve is a function of the gap; the smaller the gap, the higher the peak.

To illustrate the application of this curve, a digital Hall effect sensor with an operate (G1) and release value (G2), may be used. As the magnet moves from the right toward the sensor's reference point, it will reach point +D1 where the sensor will operate. Continue the motion in the same direction and the sensor will remain ON until point -D2 is reached. If, however, the magnet's motion is reversed prior to reaching point -D2, then the sensor will remain ON until the magnet is back at point +D2. Thus, this mode may be used with either continuous or reciprocating motion. The point at which the sensor will operate is directly dependent on the direction in which the magnet approaches the sensor. Care must be taken in using this mode in bi-directional systems. Actual graphs of various magnets (gauss versus distance) are shown in Appendix C.

### Bipolar slide-by mode

Bipolar slide-by mode (1), illustrated in Figure 3-10, consists of two magnets, moving in the same fashion as the unipolar slide-by mode. In this mode, distance is measured relative to the center of the magnet pair and the sensor's reference point. The gauss versus distance relationship for this mode is an "S" shaped curve which has both positive and negative excursions, thus the term bipolar. The positive and negative halves of the curve are a result of the proximity of the magnet's north or south pole, and whether it is to the right or left of the sensor's reference point. MICRO SWITCH Sensing and Control recommends using magnets with a high permeance in this type of application.

To illustrate the effect of this curve, a digital (ON-OFF) Hall effect sensor may be used with an operate and release value of G1 and G2. As the magnet assembly is moved from right to left, it will reach point D2 where the sensor will be operated. If the motion continues in the same direction, the sensor will remain ON until point D4 is reached. Thus, in a continuous right to left movement, the sensor will be operated on the steep portion of the curve, and OFF for the shallow tail of the curve. For left to right movement, the converse is true. (Actual graphs - gauss versus distance - are shown in Appendix C.)

A variation of the slide-by mode (1) is illustrated in Figure 3-11, bipolar slide-by mode (2). In this mode, the two magnets are separated by a fixed distance. The result of this separation is to reduce the steepness of the center portion of the curve. (Actual graphs - gauss versus distance - are shown in Appendix C.)

Yet another variation of the bipolar slide-by mode is shown in Figure 3-12, bipolar slide-by mode (3). In this mode, a magnet with its south pole facing the sensor's reference point is sandwiched between two magnets with the opposite orientation. The "pulse-shaped" curve resulting from this magnet

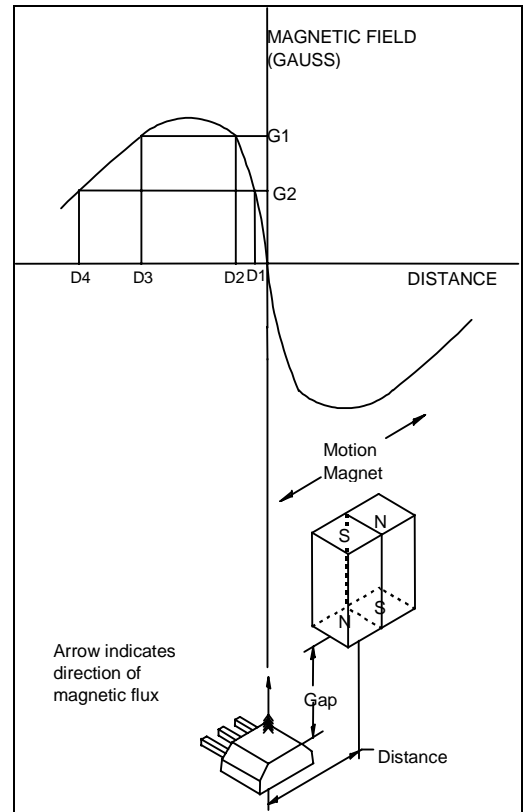

Figure 3-10 Bipolar slide-by mode (1)

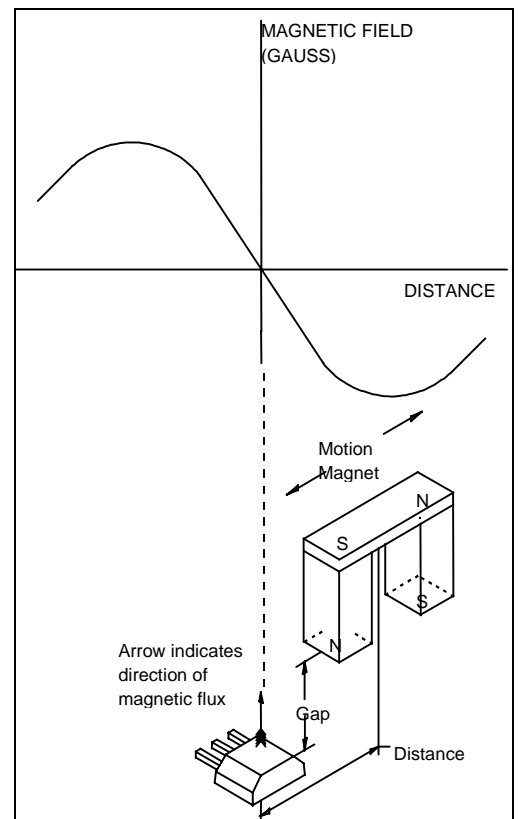

Figure 3-11 Bipolar slide-by mode (2)

## Chapter 3 • Magnetic Considerations

configuration is symmetrical along the distance axis and has a positive peak somewhat reduced from its negative peaks.

When a digital output Hall effect sensor is used, actuation will occur on either the left or right slope of the curve, depending upon the direction of travel. The distance between the two operate points depends on the width of the “pulse” that, in turn, is a function of the width of the center magnet. MICRO SWITCH Sensing and Control recommends using magnets with a high permeance for this type of application.

### Bipolar slide-by mode (ring magnet)

Another variation on the bipolar slide-by mode results from using a ring magnet, as shown in Figure 3-13. A ring magnet is a disk-shaped piece of magnetic material with pole pairs magnetized around its circumference.

In this mode, rotational motion results in a sine wave shaped curve. The ring magnet illustrated in Figure 3-13 has two pole pairs (north/south combination). Ring magnets are available with various numbers of pole pairs depending on the application. It should be noted that the greater the number of pole pairs, the smaller the peak gauss level available from the magnet. Because of the difficulty in producing a magnet with totally uniform material around the circumference, a true sine wave output is seldom realized.

When a ring magnet is used in conjunction with a digital output Hall effect sensor, an output pulse will be produced for each pole pair. Thus, for a 30 pole pair ring magnet, 30 pulses per revolution can be obtained. (Actual graphs of various ring magnets - gauss versus distance - are shown in Appendix C.)

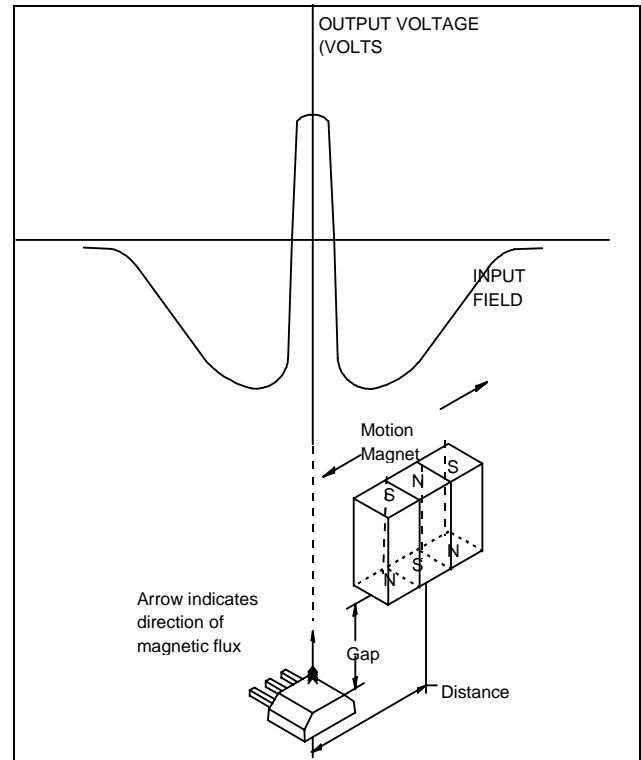

Figure 3-12 Bipolar slide-by mode (3)

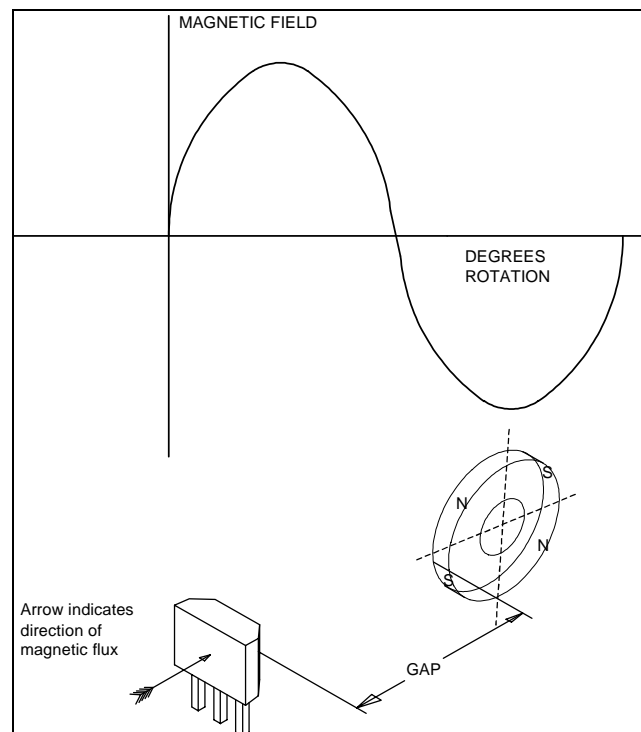
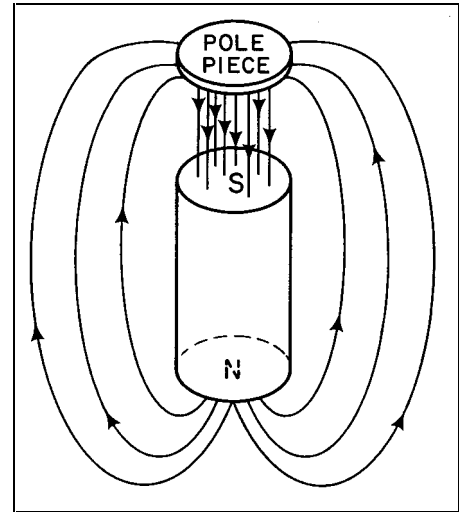

Figure 3-13 Bipolar slide-by mode (ring magnet)

**Systems with pole pieces**

Sometimes it is more cost-effective to use magnetically soft materials, known as pole pieces or flux concentrators with a smaller magnet. When added to a magnetic system, they provide a “lower resistance path” to the lines of flux. As a result, pole pieces tend to channel the magnetic field, changing the flux densities in a magnetic circuit. When a pole piece is placed opposite the pole face of a magnet, as in Figure 3-14, the flux density in the air gap between the two is increased. The flux density on the opposite side of the pole piece is similarly decreased.

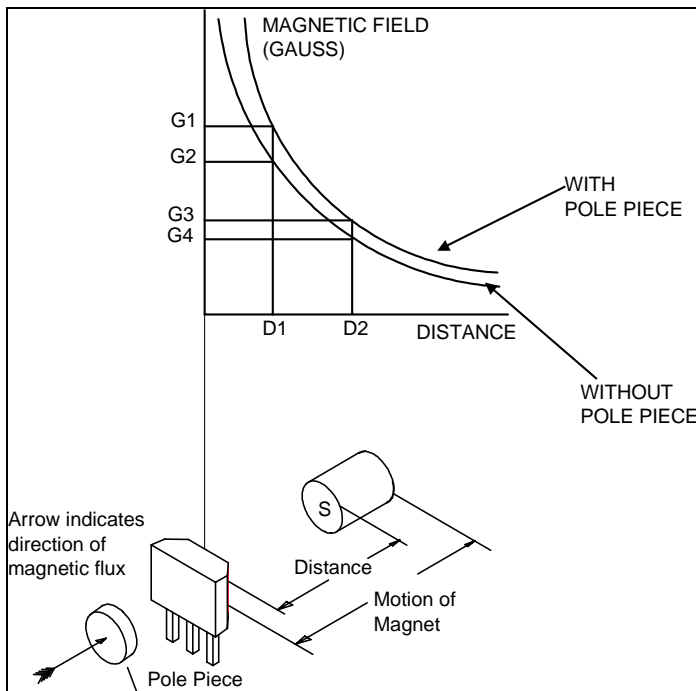

**Figure 3-14 Magnet with pole pieces**

When a pole piece is added to a magnetic system operating in the unipolar head-on mode, the change in magnetic field density illustrated in Figure 3-15 results. The flux density increase, caused by the pole piece, becomes greater as the magnet approaches the sensor’s reference point. When a digital Hall effect sensor is used, three distinct benefits from a pole piece can be realized. For actuation at a fixed distance, D1, a pole piece increases the gauss level and allows use of a less sensitive sensor.

Figure 3-16 demonstrates the second benefit that can be realized through the use of a pole piece. For a sensor with a given operate level (G1), the addition of a pole piece allows actuation at a greater distance (D2 as opposed to D1).

The final benefit is that the addition of a pole piece would allow the use of a magnet with a lower field intensity. The addition of a pole piece (flux concentrator) to the magnetic circuit does not change the characteristics of the sensor. It merely concentrates more of the magnetic flux to the sensor. Thus a pole piece makes it possible to use a smaller magnet or a magnet of different material to achieve the same operating characteristics. It should be noted that pole pieces provide the same benefits in all previously mentioned modes of operation. Because of the resulting benefits from the use of pole pieces, MICRO SWITCH Sensing and Control has integrated them into many sensor packages to provide high device sensitivity.



**Figure 3-15 Unipolar head-on mode with pole piece**

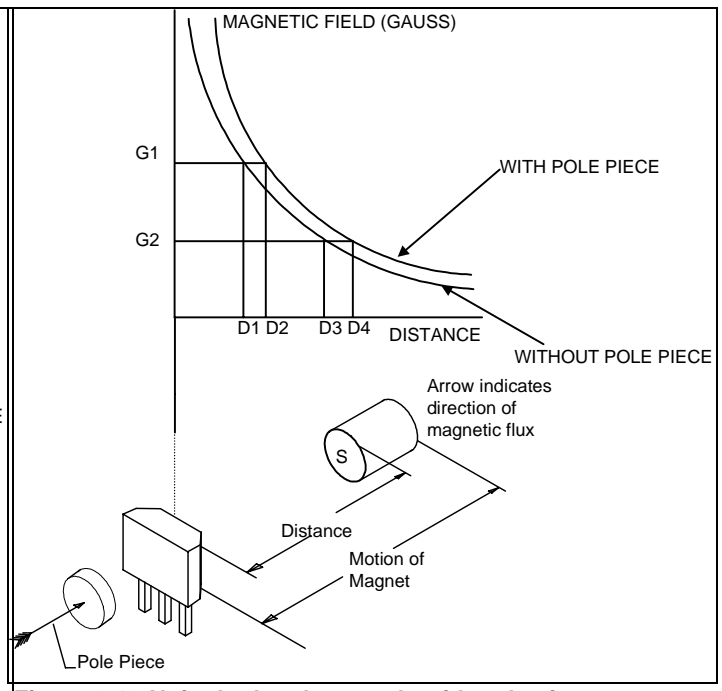

**Figure 3-16 Unipolar head-on mode with pole piece**

**Systems with bias magnets**

Magnetic systems (circuit) can be altered by the addition of a stationary or bias magnet. The effect of a bias magnet is to provide an increase or decrease (bias) in flux density at the sensor's reference point. In Figure 3-17, a bias magnet is introduced into a magnetic system moving in a unipolar head-on mode. The bias magnet is oriented with its poles in the same direction as the moving magnet, resulting in an additive field at the sensor's reference point.

The reverse orientation of the bias magnet is shown in Figure 3-18. In this configuration, a bias field will be introduced which subtracts from the field of the moving magnet, resulting in a bipolar mode. Bias magnets can also be used with other modes previously discussed.

The position of the bias magnet can be adjusted so as to "fine tune" the characteristics of the magnetic curve. The bias magnet can be used to adjust the operate or release distance of a digital output Hall effect sensor.

Caution should be taken when using bias magnets, as opposing magnetic fields will cause partial demagnetization. As a consequence, only magnets with high coercivity (i.e. rare earth magnets) should be used in such configurations.

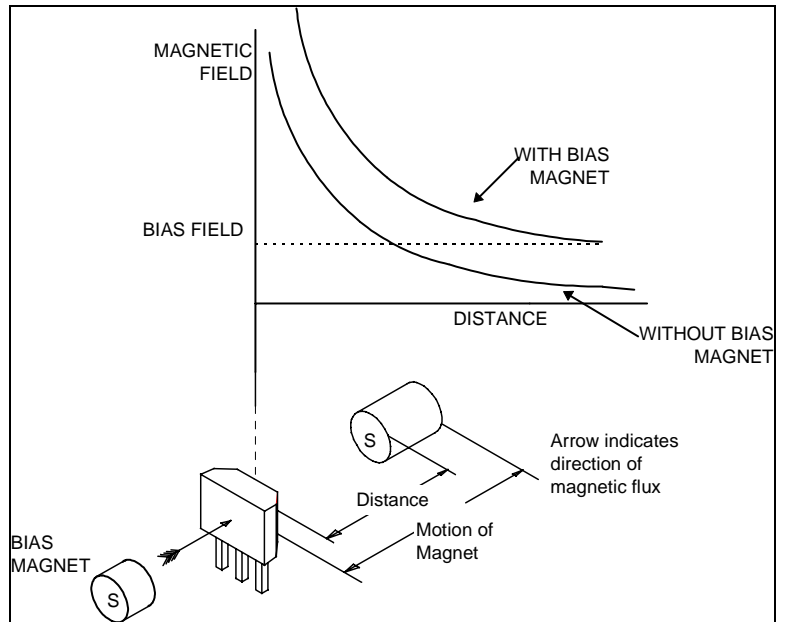

**Figure 3-17 Unipolar biased head-on mode**

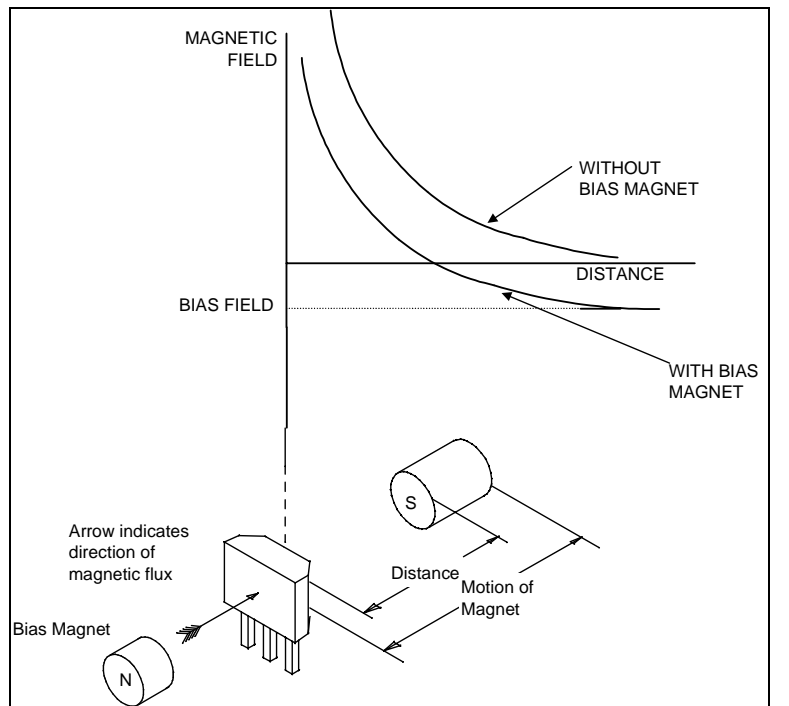

**Figure 3-18 Bipolar biased head-on mode**

### Magnetic systems comparison

The table in Figure 3-19 provides a comparison of the various modes that have been examined. The list of modes presented is by no means complete, but is rather representative of the most common magnetic systems.

Figure 3-19 Magnetic systems comparison chart

Mode	Motion Type	Mechanical Complexity	Symmetry	Recommended Applications		
				Digital	Linear	Precision
Unipolar Head-on	Reciprocating	Low	Not Applicable	Unipolar	No	Medium
Unipolar Slide-by	All*	Low-Medium	Yes	Unipolar	No	Low
Bipolar Slide-by (1)	All*	Low-Medium	No	Any	Yes	Medium
Bipolar Slide-by (2)	All*	Medium	No	Any	Yes	High
Bipolar Slide-by (3)	All*	Low-Medium	Yes	Any	Yes	High Medium
Bipolar Slide-by (Ring)	Rotational	Low	Yes	Any	Yes	Low

\*Reciprocating, Continuous and Rotational

**Motion type** refers to the manner in which the system magnet may move. These types include:

- Continuous motion . . . motion with no changes in direction
- Reciprocating motion . . . motion with direction reversal
- Rotational motion . . . circular motion which is either continuous or reciprocating.

**Mechanical complexity** refers to the level of difficulty in mounting the magnet(s) and generating the required motion.

**Symmetry** refers to whether or not the magnetic curve can be approached from either direction without affecting operate distance.

**Digital** refers to the type of sensor, either unipolar or bipolar, recommended for use with the particular mode.

**Linear** refers to whether or not a portion of the gauss versus distance curve (angle relationship) can be accurately approximated by a straight line.

**Precision** refers to the sensitivity of a particular magnetic system to changes in the position of the magnet.

A definite relationship exists between the shape of a magnetic curve and the precision that can be achieved. Assume the sloping lines in Figure 3-20 are portions of two different magnet curves. G1 and G2 represent the range of actuation levels (unit to unit) for digital output Hall effect sensors. It is evident from this illustration that the curve with the steep slope (b) will give the smaller change in operate distance for a given range of actuation levels. Thus, the steeper the slope of a magnetic curve, the greater the accuracy that can be achieved.

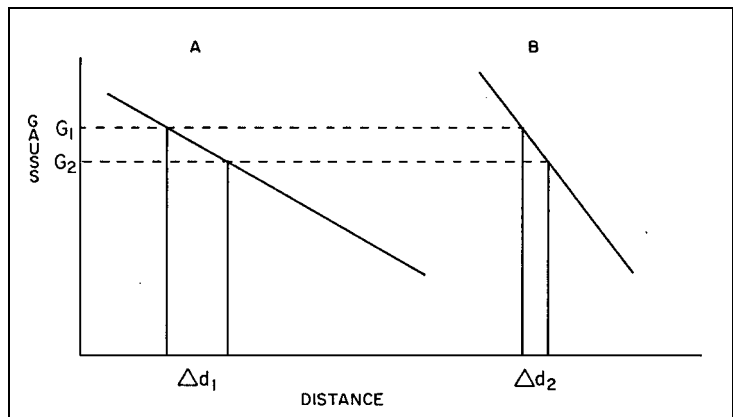

Figure 3-20 Effect of slope

All of the magnetic curves previously presented have portions steeper than others. It is on the steepest portions of these curves that Hall sensors must be actuated to achieve the highest precision. A magnetic curve or circuit is referred to as high precision if a small change in distance corresponds to a sufficiently large change in gauss to encompass the range in device actuation levels and other system variables. Thus, only magnetic curves with long steep regions are classified as high precision.

### Ratiometric Linear Hall effect sensors

Ratiometric linear sensors are small, versatile Hall effect sensors. The ratiometric output voltage is set by the supply voltage and varies in proportion to the strength of the magnetic field. It utilizes a Hall effect-integrated circuit chip that provides increased temperature stability and sensitivity. Laser trimmed thin film resistors on the chip provide high accuracy and temperature compensation to reduce null and gain shift over temperature. The ratiometric linear sensors respond to either positive or negative gauss, and can be used to monitor either or both magnetic poles. The quad Hall sensing element makes the device stable and predictable by minimizing the effects of mechanical or thermal stress on the output. The positive temperature coefficient of the sensitivity (+0.02%/°C typical) helps compensate for the negative temperature coefficients of low cost magnets, providing a robust design over a wide temperature range. Rail-to-rail operation (over full voltage range) provides a more usable signal for higher accuracy.

The ratiometric linear output Hall effect sensor is an important and useful tool. It can be used to plot gauss versus distance curves for a particular magnet in any of the magnetic systems previously described. When used in this way, various magnetic system parameters such as gap, spacing (for multiple magnet systems), or pole pieces can be evaluated. The ratiometric linear sensor can be used to compare the effects of using different magnets in a given magnetic system. It can also be used to determine the gauss versus distance relation for magnetic systems not covered, but that may hold promise in a given application. Designing the magnetic system may involve any or all of the above applications of the ratiometric linear Hall effect sensor.

### Summary

In this chapter, the basic concepts pertaining to magnets, magnetic systems, and their relation to Hall effect sensors were explored. Magnetic systems were investigated in order to give the designer a foundation on which to design sensing systems using Hall effect sensors. The ratiometric linear output Hall effect sensor was introduced. The criteria used in selecting a particular magnet and magnetic systems to perform a specific sensing function will be examined in Chapter 6.



# Chapter 4

# Electrical Considerations

## Introduction

To effectively apply Hall effect technology, it is necessary to understand the sensor, its input and its output. The previous two chapters covered the sensor and its input. This chapter covers electrical considerations as they relate to the output of a Hall effect sensor.

There are two types of Hall effect sensor outputs: analog and digital. They have different output characteristics and will be treated separately in this chapter. Analog sensors provide an analog output voltage which is proportional to the intensity of the magnetic field input. The output of a digital sensor is two discrete levels, 1 or 0 (ON or OFF), never in between. Output specifications, basic interfaces and interfaces to common devices will be examined for both sensor types.

## Digital output sensors

The output of a digital Hall effect sensor is NPN (current sinking, open collector), as shown in Figure 4-1. The illustration shows the outputs in the actuated (ON) state.

Current sinking derives its name from the fact that it “sinks current from a load.” The current flows **from the load** into the sensor. Current sinking devices contain NPN integrated circuit chips. The physics of chip architecture and doping are beyond the scope of this book.

Like a mechanical switch, the digital sensor allows current to flow when turned ON, and blocks current flow when turned OFF. Unlike an ideal switch, a solid state sensor has a voltage drop when turned ON, and a small current (leakage) when turned OFF. The sensor will only switch low level DC voltage (30 VDC max.) at currents of 20 mA or less. In some applications, an output interface may be current sinking output, NPN.

Figure 4-2 represents an NPN (current sinking) sensor. In this circuit configuration, the load is generally connected between the supply voltage and the output terminal (collector) of the sensor. When the sensor is actuated, turned ON by a magnetic field, current flows through the load into the output transistor to ground. The sensor’s supply voltage ( $V_S$ ) need not be the same value as the load supply ( $V_{LS}$ ); however, it is usually convenient to use a single supply. The sensor’s output voltage is measured between the output terminal (collector) and ground (-). When the sensor is not actuated, current will not flow through the output transistor (except for the small leakage current). The output voltage, in this condition, will be equal to  $V_{LS}$  (neglecting the leakage current). When the sensor is actuated, the output voltage will drop to ground potential if the saturation voltage of the output

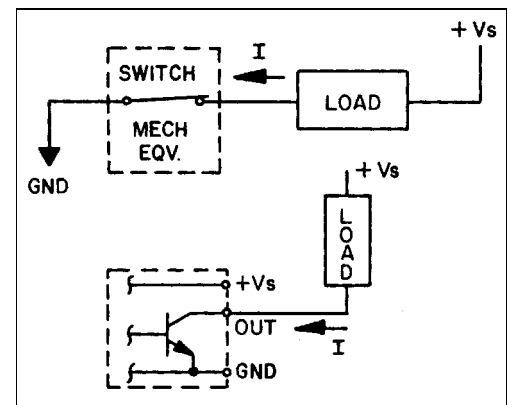

Figure 4-1 NPN output

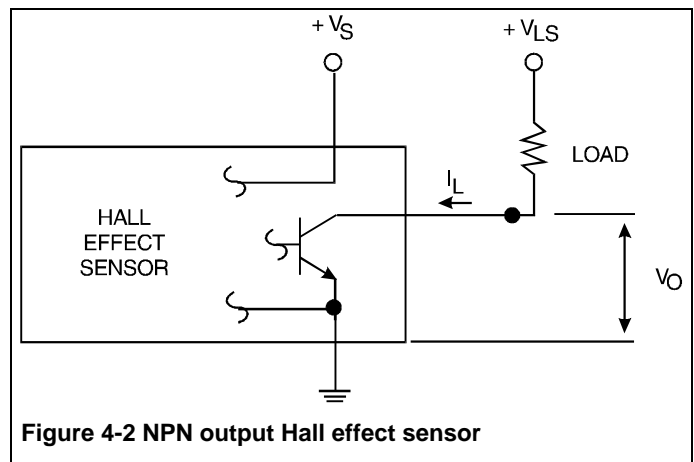

Figure 4-2 NPN output Hall effect sensor

## Chapter 4 • Electrical Considerations

transistor is neglected. In terms of the output voltage, an NPN sensor in the OFF condition is considered to be normally high.

### Electrical specifications

An example of typical characteristics of an NPN (current sinking) sensor are shown in the tables in Figure 4-3. The characteristics are divided into Absolute Maximum Ratings and Electrical Characteristics.

Absolute maximum ratings are the extreme limits that the device will withstand without damage to the device. However, the electrical and mechanical characteristics are not guaranteed as the maximum limits (above recommended operating conditions) as approached, nor will the device necessarily operate at absolute maximum ratings.

Figure 4-3A Typical NPN sensor characteristics

#### Absolute Maximum Ratings

Supply Voltage (VS)	-1.0 to +30 VDC
Voltage externally applied to output	+25 VDC max. OFF only -0.5 VDC min. OFF or ON
Output Current	50 mA max.
Temperature	-40 to +150°C operating
Magnetic flux	No limit. Circuit cannot be damaged by magnetic overdrive

Absolute Maximum Ratings are the conditions if exceeded may cause permanent damage. Absolute Maximum Ratings are not continuous ratings, but an indication of the ability to withstand a transient condition without permanent damage. Function is not guaranteed. Rated operating parameters are listed under Electrical Characteristics.

Figure 4-3B Typical NPN sensor characteristics

#### Electrical Characteristics

Parameters	Min.	Typ.	Max.
Supply Voltage (VDC)	3.8		30
Supply current (mA)			10.0
Output voltage (operated) volts		0.15	0.40
Output current (operated) mA			20
Output leakage current (released) $\mu$ A			10
Output switching time (sinking 10 mA)			
Rise time 10 to 90%			1.5 $\mu$ s
Fall time 90 to 10%			1.5 $\mu$ s

### Specification definitions

#### Absolute Maximum Ratings

Supply voltage refers to the range of voltage which may be applied to the positive (+) terminal of a sensor without damage. The sensor may not, however, function properly over this entire range.

Voltage externally applied to output refers to the breakdown voltage of the output transistor between its collector and emitter when the transistor is turned OFF ( $BV_{CER}$ ). Voltage measured at the output terminals of an inactivated sensor must never exceed 30 VDC or the device may be damaged. If the sensor is used in a single supply ( $V_S = V_{LS}$ ) configuration, the 30 VDC maximum rating of the supply insures that this limit will never be exceeded.

**Output Current** specifies the maximum output current that may flow without damage when the sensor is actuated.

**Temperature** refers to the temperature range that the sensor may be operated within without damage. This temperature range is distinguished from the rated temperature range over which the sensor will meet specific operational characteristics.

**Magnetic flux** – a Hall effect sensor cannot be damaged by excessively large magnetic field densities.

**Rated Electrical Characteristics**

**Supply voltage** refers to the voltage range over which the sensor is guaranteed to operate within performance specifications.

**Supply current** corresponds to the current drain on the  $V_S$  terminal. The supply current is dependent on the supply voltage.

**Output voltage (operated)** refers to the saturation voltage ( $V_{SAT}$ ) of the output transistor. This is the voltage that appears at the output due to the inherent voltage drop of the output transistor in the ON condition.

**Output current (operated)** refers to the maximum output current at which the sensor is guaranteed to operate within performance specifications.

**Output leakage current** is the maximum allowable current that remains flowing in the output transistor after it is turned OFF.

**Output switching time** refers to the time necessary for the output transistor to change from one logic state to another after a change in actuating field. This specification only applies to conditions specified on product drawings.

**Basic interfaces**

When the electrical characteristics are known, it is possible to design interfaces that are compatible with NPN (current sinking) output Hall effect sensors. The current sink configuration produces a logic “0” condition when a magnetic field of sufficient magnitude is applied to the sensor.

Current sinking sensors may be operated with a dual supply; one for the sensor and a separate supply for the load.

Certain conditions must be met for interfacing with sinking output sensors:

- the interface must appear as a load that is compatible with the output
- the interface must provide the combination of current and voltage required in the application

**Pull-up resistors**

It is common practice to use a pull-up resistor for current sinking. This resistor minimizes the effect of small leakage currents from the sensor output or from the interfaced electronics. In addition, they provide better noise immunity along with faster rise and fall times.

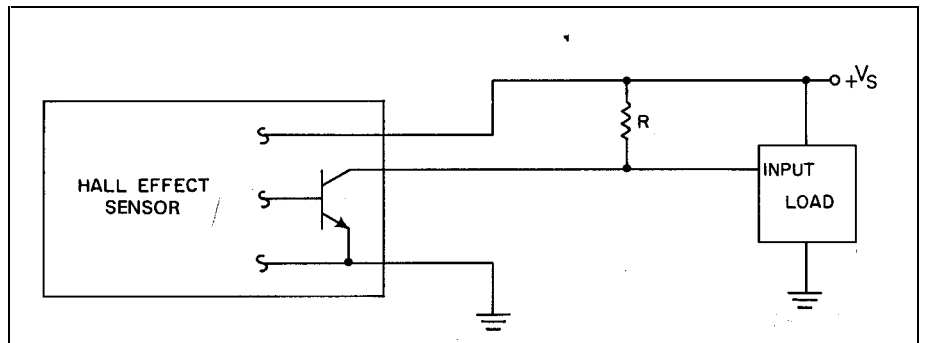

**Figure 4-4 Pull-up resistor interface**

The current sinking output is an open collector. The output is floating, so the pull-up resistor helps establish a solid quiescent voltage level. When selecting the pull-up resistor, it must be determined if the interface will tolerate a resistance in parallel with it. If there is a parallel resistance, the total resistance and load current should be calculated to make sure that the Hall effect sensor’s output current will not be exceeded.

The basic interface for a digital Hall effect sensor is a single resistor. When a resistor is used in conjunction with a current sinking sensor, it is normally tied between the output and the plus power supply and is referred to as a pull-up resistor. Figure 4-4 illustrates pull-up resistor (R) connected between the sensor and its load. When the sensor is actuated, the input to the load falls to near ground potential, independent of the pull-up resistor.

## Chapter 4 • Electrical Considerations

When the device is de-actuated, the input to the load is **pulled-up** to near  $V_S$ . If the pull-up resistor were not present, the input to the load could be left floating, neither at ground nor  $V_S$  potential.

### Logic gate interfaces

Digital sensors are commonly interfaced to logic gates. In most cases, the interface consists of a single pull-up or pull-down resistor on the input of the logic gate. Figure 4-5 illustrates an example of the interface to a TTL gate.

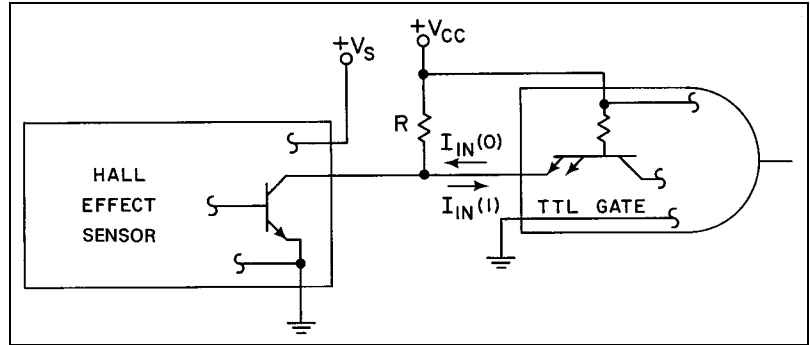

Figure 4-5 NPN sensor interfaced with TTL gate

### Transistor interfaces

To further illustrate how input and output specifications are related, consider an interface with the requirement for a higher load current than the sensor's rated output current. Figure 4-6 illustrates one of the four possible high current interfaces. The interface consists of a Hall effect sensor driving an auxiliary transistor. The transistor must have sufficient current gain, adequate collector breakdown voltage, and power dissipation characteristics capable of meeting the load requirements.

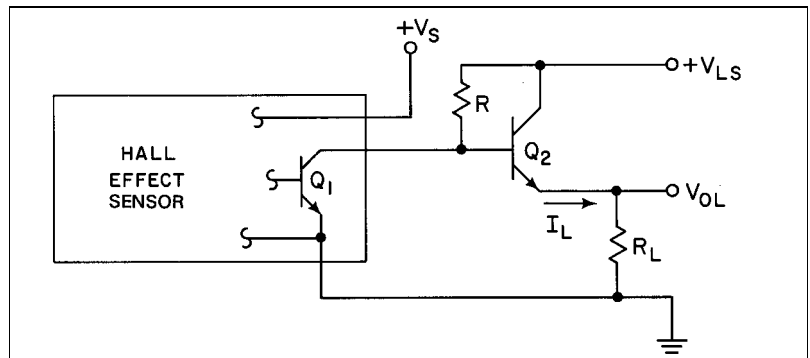

Figure 4-6 High load current interface

The rated output current of the sensor will determine the minimum value of (R). The resistor must also bias the transistor ON when the sensor is not actuated. The current required to adequately drive the transistor will determine the maximum value of (R). Since the bias voltage appears across the sensor output, it is important that the bias be less than the sensor's breakdown voltage.

Four additional combinations of transistor interfaces can be realized with current sourcing and current sinking sensors. These are:

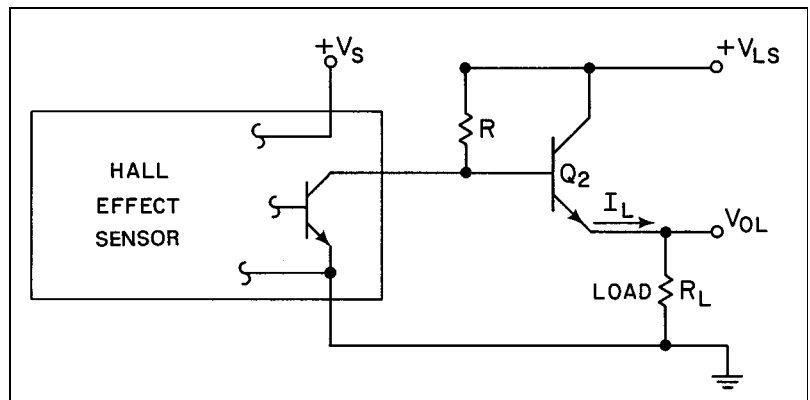

Figure 4-7 Sinking sensor - sourcing output

- Current sinking sensor with a current sourcing drive
- Current sinking sensor with a current sinking drive
- Current sourcing sensor with a current sinking drive
- Current sourcing sensor with a current sourcing drive

The design equations necessary to choose the correct bias resistors and drive transistors for the first two are shown in Figures 4-7 and 4-8. The current sourcing sensor interfaces will not be discussed any further due to lack of widespread use. The symbols used in the sensor interface design equations are defined in Figure 4-9.

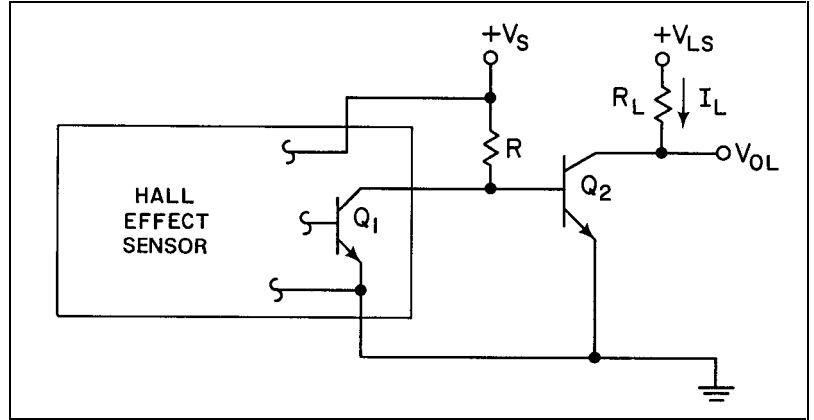

Figure 4-8 Sinking sensor - sinking output

R for a given sensor:

$$R_{min} = \frac{V_{LS} - V_{CE(Q1)}}{I_{ON}}$$

R for adequate load current:

$$R_{max} = \frac{(\beta_{min} + 1)(V_{LS} - R_L I_{L(max)}) - V_{BE(ON)}}{I_{L(max)}}$$

If  $R_{max} \leq R_{min}$  then use either a transistor with a higher  $\beta$  or a second amplifier stage.

$\beta_{min}$  for given R:

$$\beta_{min} = \frac{R_L I_{L(max)}}{V_{LS} - R_L I_{L(max)} - V_{BE(ON)}}$$

Output voltage:

$$V_{OL} = \frac{V_{LS} - V_{BE(ON)}}{1 + \frac{R}{R_L \beta + R_L}}$$

Transistor output requirements:

$$I_{L(max)} < I_{C(max)}$$

$$V_{LS} < BV_{CER}$$

Transistor power dissipation:

$$PD = I_L (V_{LS} - V_{OL}) = \frac{R V_{LS}}{1 + \frac{R}{R_L \beta + R_L} + V_{BE(ON)}}$$

R for given sensor:

$$R_{min} = \frac{V_S - V_{CE(Q1)}}{I(ON)}$$

R for adequate load current:

$$R_{max} = \frac{\beta_{min}(V_S - V_{BE(ON)})}{V_S - V_{BE(ON)}}$$

If  $R_{max} \leq R_{min}$  then use either a transistor with a high  $\beta$  or a second amplifier stage.

$\beta_{min}$  for a given R:

$$\beta_{min} = \frac{R_L I_{L(max)}}{V_S - V_{BE(ON)}}$$

Output voltage:

$$V_{OL} = V_{CE(SAT)Q2} \text{ for } I_L$$

## Chapter 4 • Electrical Considerations

A minimum  $\beta$  of 10 is recommended for good saturation voltage.

Transistor output requirements:	Transistor power dissipation:
$I_{L(max)} < I_{C(max)}$	$P_D = V_{OL} \cdot I_L$
$V_{LS} < BV_{CER}$	

### Symbols for design calculations

$BV_{CEO}$	=	Collector-to-emitter breakdown voltage with base open
$BV_{CER}$	=	Collector-to-emitter breakdown voltage with resistor from base-to-emitter
$BV_{EBO}$	=	Emitter-to-base breakdown voltage, junction reverse biased, collector open circuited
$I_{C(max)}$	=	Maximum collector current rating
$I_{L(max)}$	=	Maximum load current
$I_{(ON)}$	=	Sensor rated output current
$V_{CE(Q2)}$	=	Driver transistor voltage drop
$R_L$	=	Load resistance
$V_{BE(ON)}$	=	Base-emitter forward voltage drop when transistor is ON (typically 0.7 V)
$V_{LS}$	=	Load power supply voltage
$V_S$	=	Sensor supply voltage
$\beta$	=	DC current gain of drive transistor
$I_{CBO}$	=	Collector-to-base leakage current
$I_L$	=	Load current
$I_{(OFF)}$	=	Sensor output transistor leakage current
$V_{CE(Q1)}$	=	Sensor output transistor voltage drop
$P_D$	=	Drive transistor power dissipation
$V_{BE(OFF)}$	=	Forward base-emitter voltage drop when transistor is OFF (typically 0.4 V)
$V_{OL}$	=	Output voltage
$I_S$	=	Sensor supply current in ON condition

Figure 4-9 Design calculation symbols

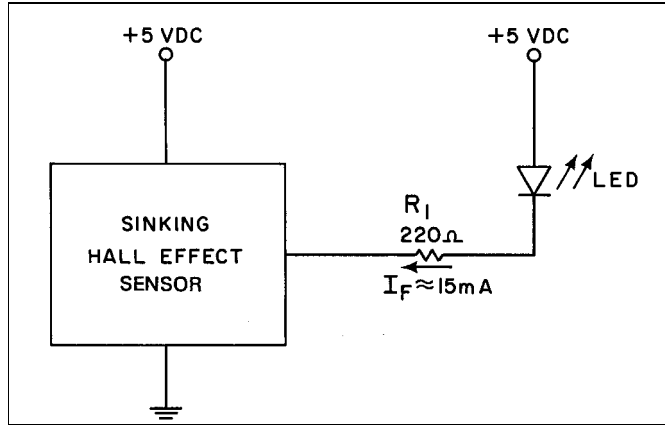

Figure 4-10 Sinking sensor interfaced to normally OFF LED

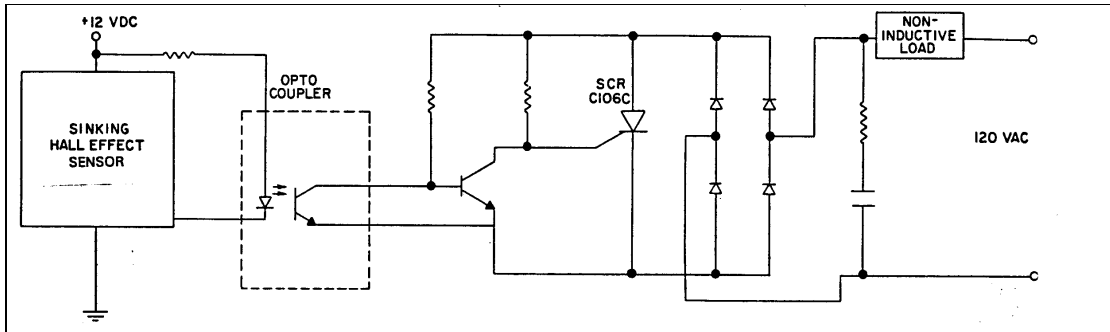

Figure 4-11 Sinking sensor interfaced to normally OFF SCR

For C106C: Breakdown voltage = 300 VDC

Current rating = 4 amperes

Sensor:  $I_{(ON)} = 20 \text{ mA}$

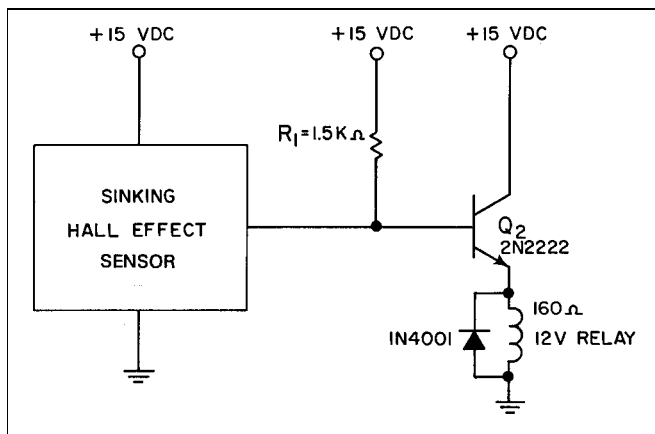

Figure 4-12 Sinking sensor interfaced to normally ON relay

## Chapter 4 • Electrical Considerations

For 2N2222:  $V_{BE(ON)} = 0.7 \text{ V}$

$$\beta_{\min} = 75$$

Sensor:  $V_{CE(SAT)Q1} = 0.15 \text{ V}$   $I_{ON} = 20 \text{ mA}$

For load:  $I_{L(max)} = 81 \text{ mA}$

For design equations, see Figure 4-7.

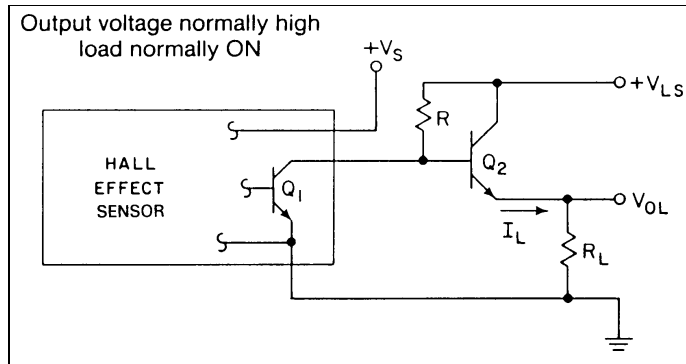

**Figure 4-13 Sinking sensor interfaced to normally ON solenoid**

For 2N3715:  $\beta_{\min} = 50$

Sensor:  $V_{CE(SAT)Q1} = 0.15 \text{ V}$

For load  $I_{L(max)} = 911 \text{ mA}$

$V_{BE(ON)} = 0.7 \text{ V}$

$I_{ON} = 20 \text{ mA}$

For design equations, see Figure 4-8.

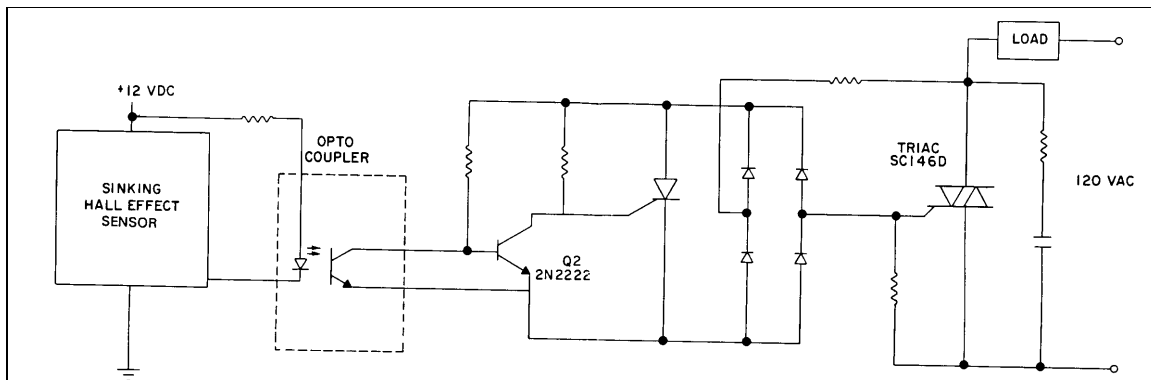

**Figure 4-14 Sinking sensor interfaced to normally OFF triac**



For SC146D: Breakdown voltage = 400 V

Current rating = 10 A

For 2N2222:  $V_{BE(ON)} = 0.5 \text{ V}$

$\beta_{min} = 75$

Sensor:  $V_{CE(Q1)} = 0.15 \text{ V}$

Input voltage = 2.5 V

Input current = 50 mA

$I_{CBO} = 10 \mu\text{A}$

$I_{(ON)} = 10 \text{ mA}$

Other digital output sensor interface circuits can provide the functions of counting, latching, and the control of low level AC signals. Figures 4-15 through 4-17 demonstrate how these functions can be achieved.

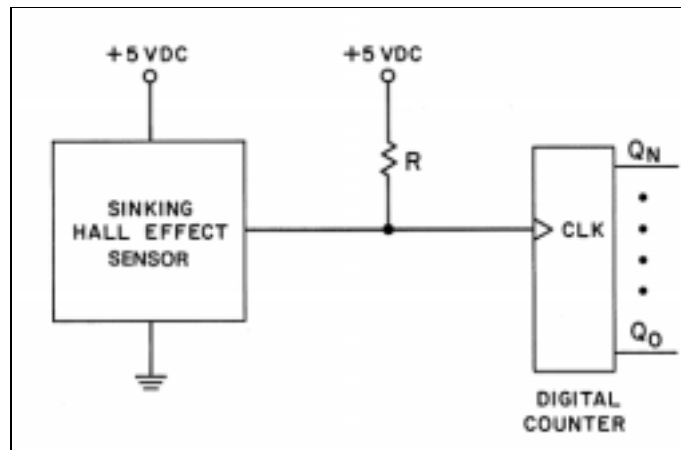

Figure 4-15 Sinking sensor interfaced to digital counter

Counter output is a binary representation of the number of times the sensor has been actuated.

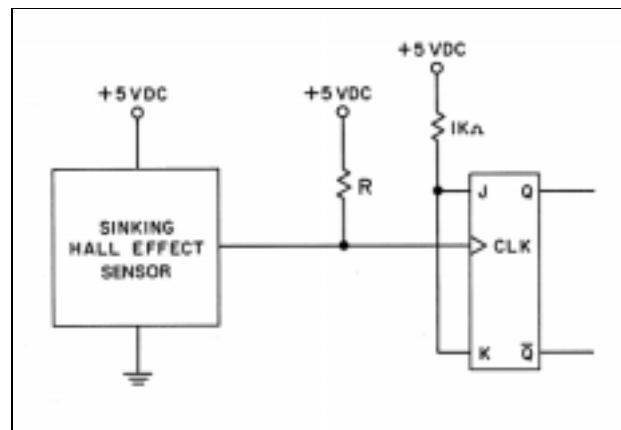

Figure 4-16 Sinking sensor interfaced to a divide by 2 counter

## Chapter 4 • Electrical Considerations

Latch output remains in the same state until sensor is actuated a second time.

Three additional interface circuits which extend the capabilities of digital output Hall effect sensors are shown in Figures 4-18 through 4-20. Figure 4-18 demonstrates how more than one Hall effect sensor may be connected in parallel. This configuration is known as **wired OR** since a logic 0 will be provided to the input of the TTL gate if any combination of sensors is actuated. It is important to note that only current sinking sensors may be tied in parallel.

$$R_{\min} = \frac{V_{CC} - V_{O(0)}}{I_{(ON)} - nI_{IN(0)}}$$

$$R_{\max} = \frac{V_{CC} - V_{IN(1)}}{nI_{(OFF)} - nI_{IN(1)}}$$

Where:

N	=	number of sensors in parallel
$V_{IN(1)}$	=	Minimum input voltage to insure logic 0
$V_{O(0)}$	=	Maximum output voltage of sensor for logic 0
$I_{IN(0)}$	=	Maximum input current per unit load at $V_{O(0)}$
$I_{IN(1)}$	=	Maximum input current per unit load at $V_{IN(1)}$

When a Hall effect sensor is placed in a remote location, it may be desirable to convert its three terminals to a two-wire current loop as shown in Figure 4-19. When the sensor is not actuated, the current in the loop will be equal to the sensor supply current plus leakage current. Conversely, when the sensor is actuated, the loop current will increase to equal the supply current plus the current flow in the output transistor. The difference in loop current will cause a voltage change across the sense resistor  $R_2$  that in turn, reflects the state (ON or OFF) of the sensor. The comparator will then detect this change by comparing it against a fixed reference. Since this changing voltage ( $V_1$ ) is also the sensor supply voltage, the sensor must also have internal regulator. The value of  $R_2$  must also be chosen so that when the sensor is actuated,  $V_1$  does not fall below the minimum supply rating of the Hall effect sensor.

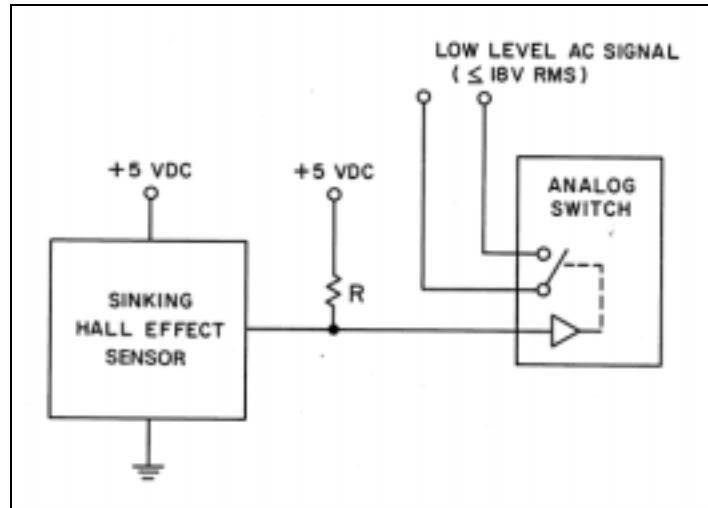

Figure 4-17 Sinking sensor interfaced to analog switch

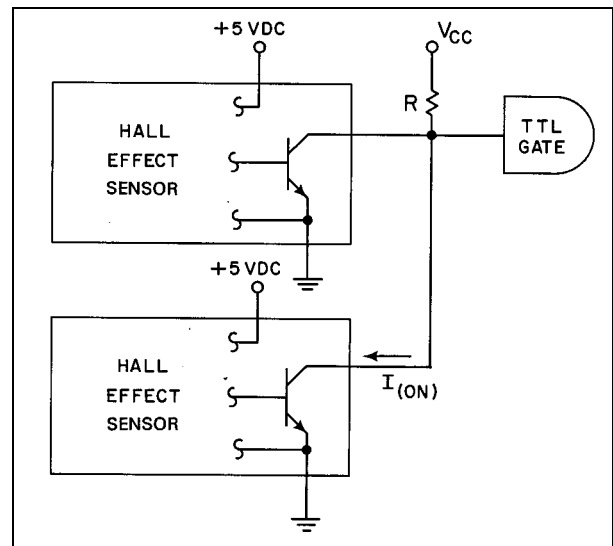

Figure 4-18 Wired OR interface

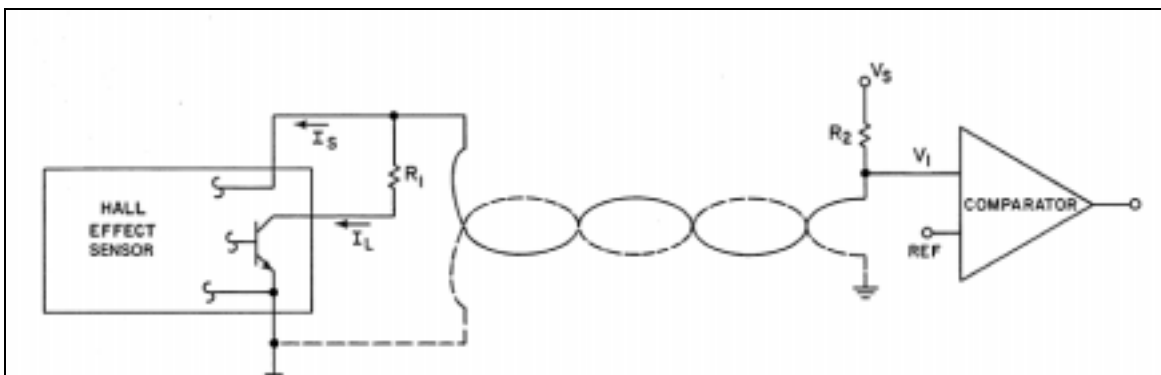

Figure 4-19 Two-wire current loop interface

$$\frac{V_S - V_{OL} - R_2 I_{S(ON)}}{R_1 + R_2} \leq I_{L \max}$$

$$V_{1(ON)} = \frac{V_S - I_{S(ON)} + R_2/R_1 V_{OL}}{1 + R_2/R_1}$$

$$V_{1(OFF)} = V_S - I_{S(OFF)} R_2$$

Two digital output Hall effect devices may be used in combination to determine the direction of rotation of a ring magnet, as shown in Figure 4-20. The sensors are located close together along the circumference of the ring magnet. If the magnet is rotating in the direction shown (counter-clockwise) the time for the south pole of the magnet to pass from sensor T<sub>2</sub> to T<sub>1</sub> will be shorter than the time to complete one revolution. If the ring magnet's direction is reversed, the time it takes the south pole to pass from T<sub>2</sub> to T<sub>1</sub> will be almost as long as the time for an entire revolution. By comparing the time between actuations of sensors T<sub>2</sub> and T<sub>1</sub> with the time for an entire revolution (successive actuations of T<sub>2</sub>), the direction can be determined.

A method by which these two times can be compared is also shown in Figure 4-20. An oscillator is used to generate timing pulses. The counter adds these pulses (counts up) starting when sensor T<sub>2</sub> is actuated and stopping when sensor T<sub>1</sub> is actuated.

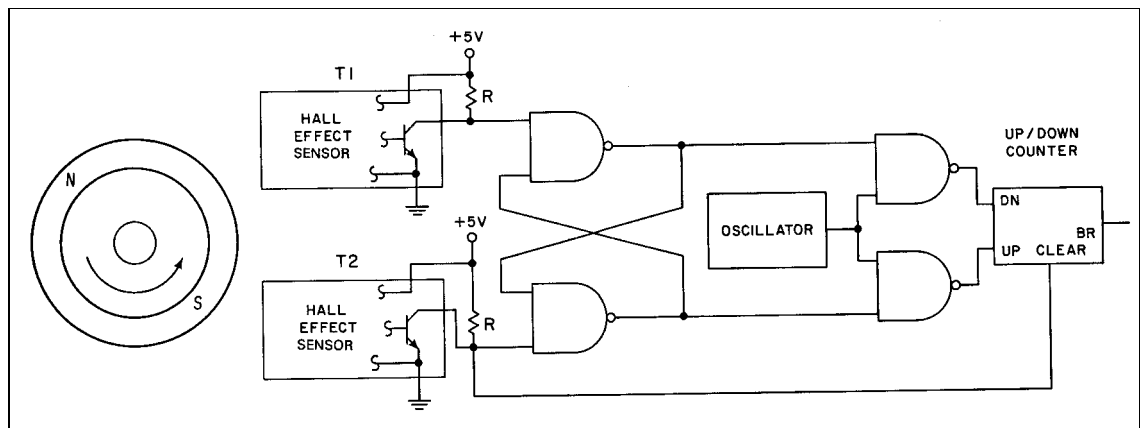

Figure 4-20 Digital output sensor direction sensor

The counter then subtracts pulses (counts down) for the remainder of the revolution. The shorter time interval between T<sub>2</sub> and T<sub>1</sub> actuation will result in fewer pulses being added than subtracted, thus actuating the counter's BR (borrow) output. When the time between T<sub>2</sub> and T<sub>1</sub> is longer, more pulses are added than subtracted and the BR output is not actuated. For the configuration shown, there will be no output for clockwise motion and a pulse output for each revolution for counterclockwise motion.

In addition to the interface design concepts covered in this section, there are many other possible ways to utilize the output of digital Hall effect sensors. For example, the output could be coupled to a tone encoder in speed detection applications or a one-shot in current sensing applications. To a large extent, the interface used is dependent on the application and the number of possible interface circuits is as large as the number of applications.

### Analog output sensors

The output of an analog Hall effect sensor is an open emitter (current sourcing) configuration intended for use as an emitter follower. Figure 4-21 illustrates the output stage of a typical analog output Hall effect sensor. The output transistor provides current to the load resistor R<sub>LOAD</sub> producing an analog voltage proportional to the magnetic field at the sensing surface of the sensor. The load in Figure 4-21 is indicated as a resistor, but in practice may consist of other components or networks.

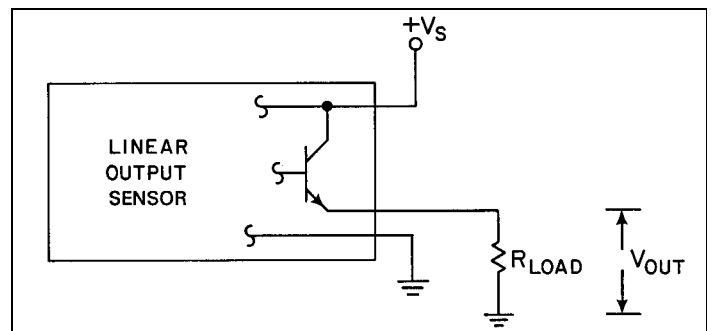

Figure 4-21 Analog output Hall effect sensor

**Electrical specifications**

Typical characteristics of an analog output Hall effect sensor are shown in Figure 4-22. These characteristics, like those of digital devices, are divided into Absolute Maximum Ratings and Electrical Characteristics. The parameters listed under Absolute Maximum Ratings are defined in the same manner as digital sensors. With the exception of output voltage at 0 gauss (null offset), span and sensitivity, the electrical characteristics are also defined the same as those for digital devices. Span, output voltage at 0 gauss or null offset, and sensitivity are transfer function characteristics that were defined in Chapter 2.

**Figure 4-22 Analog output characteristics**

**Absolute Maximum Ratings**

<b>Supply voltage (<math>V_s</math>)</b>	-1.2 and +18 VDC
<b>Output current</b>	10 mA
<b>Temperature</b>	-40 to +150°C operating
<b>Magnetic flux</b>	No limit. Circuit cannot be damaged by magnetic over-drive

**Electrical Characteristics**

	Min.	Typ.	Max.	Conditions
<b>Supply voltage, V</b>	5.0		16.0	
<b>Supply current, mA</b>			20	$V_s = 12\text{ V}$ @ $24 \pm 2^\circ\text{C}$
<b>Output current, mA</b>			10	$V_s = 12\text{ V}$
<b>Output voltage @ 0 gauss, V</b>	5.4	6.0	6.6	@ $24 \pm 2^\circ\text{C}$
<b>Span (-400 to +400 gauss), V</b>	5.84	6.0	6.16	@ $24 \pm 2^\circ\text{C}$
<b>Sensitivity, mV/G</b>	7.3	7.5	7.7	@ $24 \pm 2^\circ\text{C}$

**Basic interfaces**

When interfacing with analog output sensors, it is important to consider the effect of the load. The load must:

- provide a path to ground
- limit the current through the output transistor to the rated output current for all operating conditions.

Figure 4-23 illustrates a typical load configuration. The parallel combination of the pull-down resistor (R) and the load resistance  $R_L$  must be greater than the minimum load resistance which the sensor can drive. In general, this parallel combination should be at least 2200 ohms.

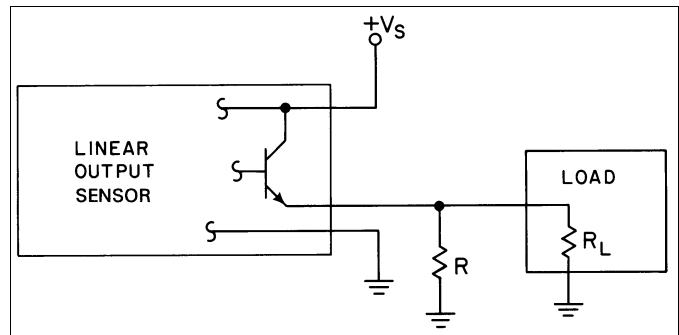

**Figure 4-23 Typical load . . . Analog output sensor**

In many cases, the output of an analog sensor is connected to a component such as a comparator or operational amplifier, with an external pull-down resistor, as illustrated in Figure 4-24. This resistor should be selected so that the current rating of the analog output sensor is not exceeded. Depending on the comparator used and the electrical noise, this resistor may not be required.

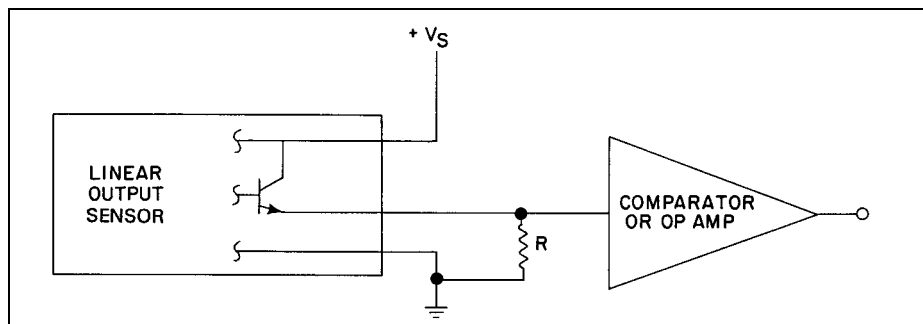

**Figure 4-24 Analog sensor interfaced with comparator**

### Interfaces to common components

The basic concepts needed to design simple interfaces to analog sensors have been presented. Using these basic techniques, more sophisticated interface circuits can be implemented. The interface circuits shown in Figures 4-25 through 4-27 demonstrate how analog Hall effect sensors can be used with standard components.

An analog sensor can be used with an operation amplifier to adjust the sensor's null offset (to zero if desired). Figure 4-25 illustrates one method of accomplishing this using an inverting operational amplifier stage.

When an analog sensor is interfaced to a comparator (level detector), a digital output system results. Figure 4-26 illustrates a system consisting of an analog output sensor and comparator circuit with no hysteresis. The comparator output will remain in the OFF state until the magnetic field reaches the trigger level. The trigger level corresponds to a voltage output from the sensor equal to the reference on the minus input of the comparator. When the magnetic field is above the trigger level, the comparator's output will be ON. This circuit provides a trigger level that can be electronically controlled by adjusting  $R_2$ . Hysteresis can also be added to the circuit with the addition of a feedback resistor (dotted) between the comparator's output and positive input.

When an analog output sensor is interfaced with two comparators, as shown in Figure 4-27, a window detector results. The output of the comparators will be ON only when the magnetic field is between trigger level 1 and trigger level 2. As in Figure 4-26, the trigger levels correspond to a sensor output voltage which is equal to reference voltages 1 and 2. This circuit is useful in applications where a band of magnetic fields needs to be developed.

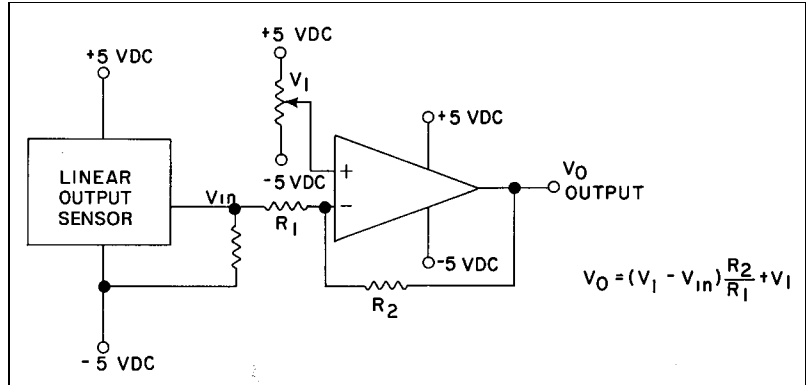

Figure 4-25 Null offset cancellation circuit

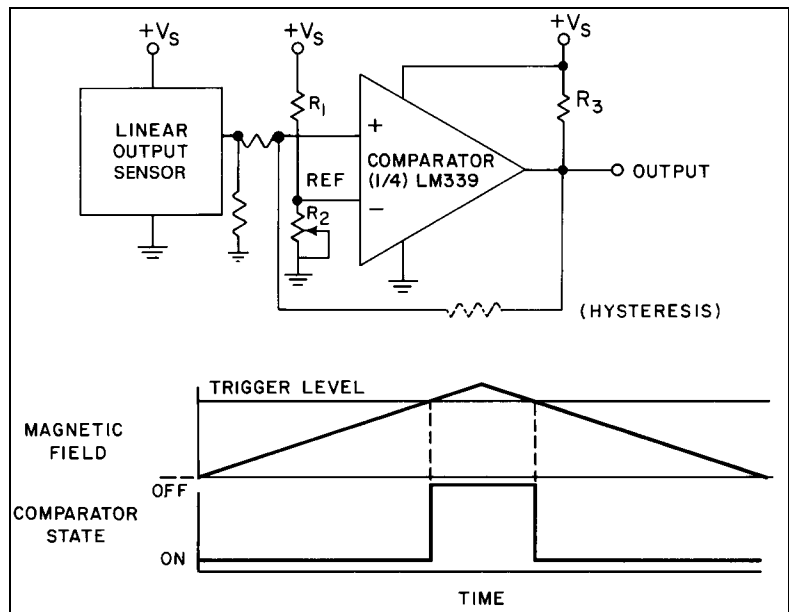

Figure 4-26 Digital system with analog sensor

### Summary

In this chapter, the concepts and techniques necessary to interface Hall effect sensors have been explored. In conjunction with the preceding two chapters, the foundation necessary to design with Hall effect sensors has been established. The remainder of this book is devoted to putting these concepts to work in the design of Hall effect based sensing systems.

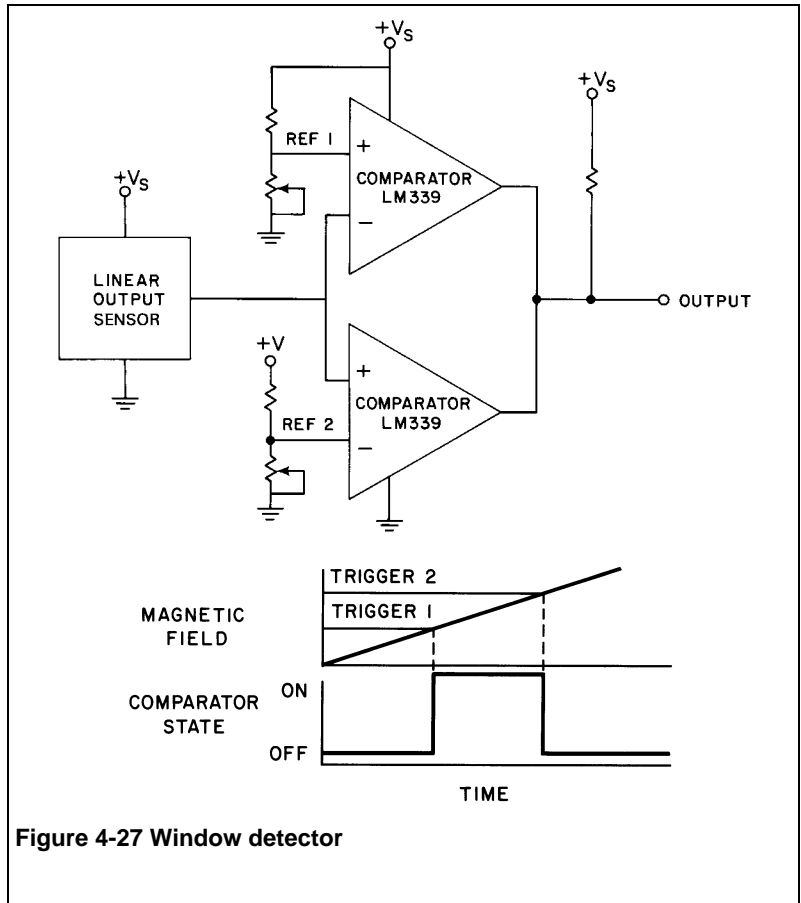

Figure 4-27 Window detector

# Hall-based Sensing Devices

## Introduction

Applying Hall effect sensors involves selecting the magnetic system and choosing the Hall sensor with the appropriate operate and release characteristics. These components must then be integrated into a system that will meet the specific application requirements. MICRO SWITCH Sensing and Control has developed a number of products that integrate the sensor and a magnetic system into a single package. Since the magnetic characteristics are pre-defined, applying these products does not involve magnetic to sensor design. Instead, applying these sensors consists of mechanical or electrical interfacing of the input.

In this chapter, vane operated position sensors, current sensors, magnetically operated solid state switches, and gear tooth sensors will be examined. For each of these products incorporating a Hall effect sensor, the principles of operation and interface requirements will be discussed. Electrical considerations as they relate to the output are the same as those presented in Chapters 2 and 4.

## Vane operated position sensors

A vane operated position sensor, sometimes referred to as a vane sensor, consists of a magnet and a digital output Hall effect sensor assembled as shown in Figure 5-1. Both the magnet and the Hall effect sensor are rigidly positioned in a package made of a non-magnetic material.

The sensor has a space or gap through which a ferrous vane may pass, as illustrated in Figure 5-2. The Hall effect sensor will detect the presence (or absence) of the vane.

## Principles of operation

Figure 5-3 shows the construction of another version of the basic vane sensor. Pole pieces have been added to direct the lines of flux by providing a low resistance path. The lines of flux, illustrated by arrows, leave the north pole of the magnet, travel through the pole piece, across the gap, and return through the sensor to the south pole. As a result, the sensor is normally ON.

The magnetic circuit (flux lines) illustrated in Figure 5-3 is altered when a vane, made of material similar to the pole pieces, is present in the gap. The vane has the effect of shunting the lines

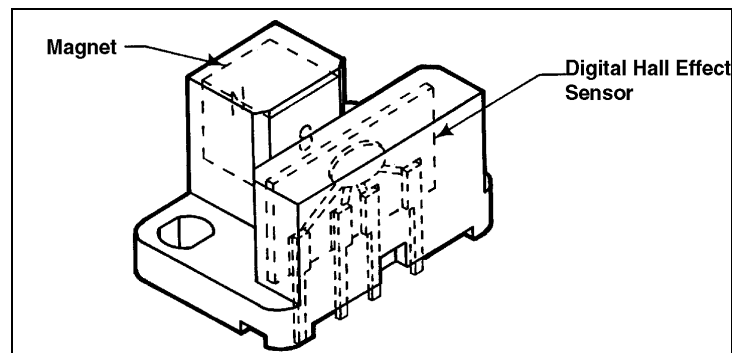

Figure 5-1 Basic vane operated position sensor

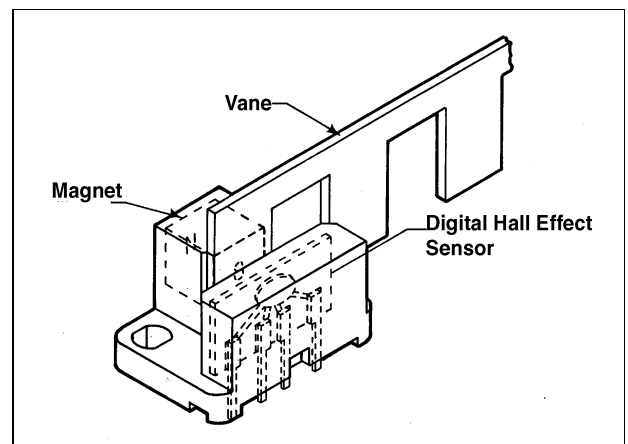

Figure 5-2 Ferrous vane in gap

## Chapter 5 • Hall-based Sensing Devices

of flux away from the sensor in the manner shown by the arrows in Figure 5-4. Thus, the sensor will be turned OFF when a vane is present in the gap.

The curve in Figure 5-5 illustrates how the magnetic field sensed by the Hall effect sensing device varies as a vane is passed through the gap. Assume the sensor has the operate and release points shown. When a vane is moved from left to right, the sensor will be ON until the leading edge of the vane reaches point b. At this point (known as the left release), the sensor will be turned OFF. If this motion is continued, the sensor will remain turned OFF until the trailing edge of the vane reaches point d. At this point (known as the right operate), the sensor is turned ON again. The total left to right distance traveled by the vane with the sensor OFF, is equal to the distance between points b and d plus the vane width.

If the vane is moved from right to left, the sensor will be ON until the leading edge of the vane reaches point c (known as the right release). The sensor is then turned OFF until the trailing edge of the vane reaches point a (left operate). The total right to left distance traveled by the vane with the sensor OFF is equal to the distance between points c and a (L release to R operate), plus the vane width.

In many cases, the vane consists of several teeth. The gaps between the individual teeth are referred to as windows. Figure 5-6 shows a vane with two teeth and a single window. If this vane is passed through the gap, the distance traveled with the sensor OFF (tooth plus b to d) will be the same as for the single tooth vane shown in Figure 5-5. The total distance traveled by the vane with the sensor ON is equal to the window width minus the distance between point d and b, or between a and c, depending on direction of travel.

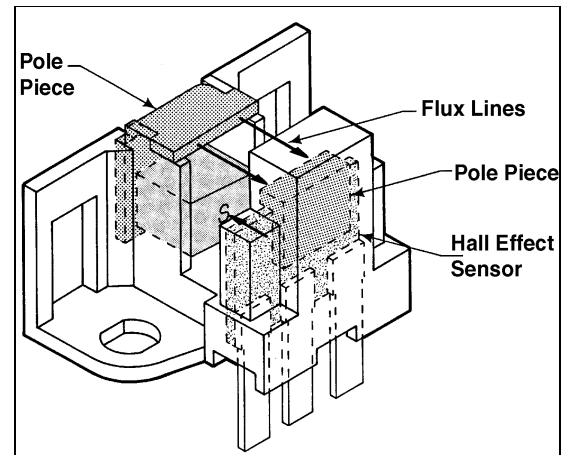

Figure 5-3 Vane operated sensor with pole pieces

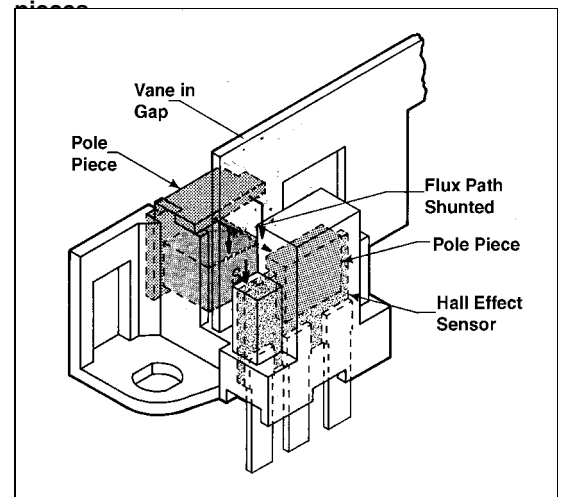

Figure 5-4 Ferrous vane in gap

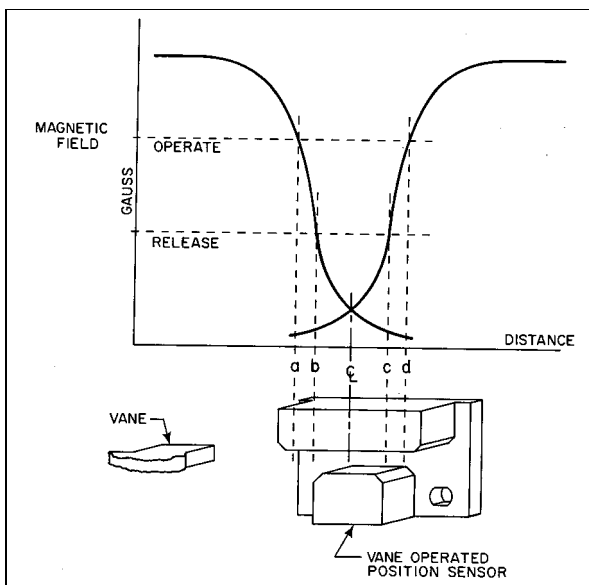

Figure 5-5 Ferrous vane passing through the gap

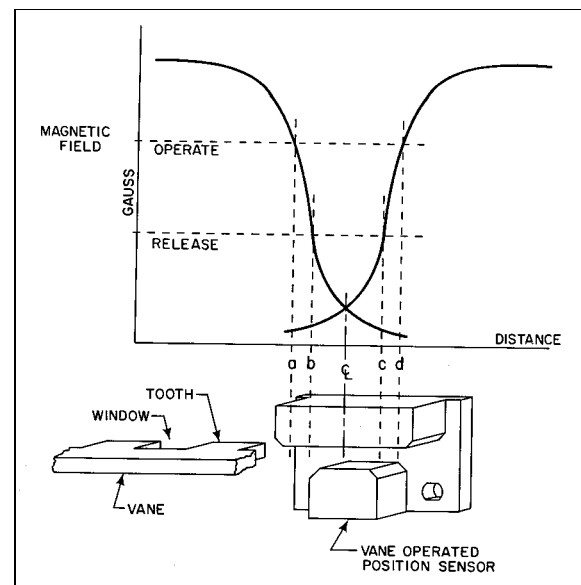

Figure 5-6 Multiple tooth vane operation

The relationships between ON and OFF travel for a multiple tooth vane are summarized in Figure 5-7.



Travel	OFF Distance	ON Distance
Left to Right	Tooth width plus (b to d)	Window width minus (d to b)
Right to Left	Tooth width plus (c to a)	Window width minus (a to c)

Figure 5-7 Relationship between ON and OFF travel

### Sensor specifications

Vane operated position sensors are specified in terms of vane characteristics and mechanical characteristics. Mechanical characteristics are the left and right operate and release points previously discussed. Vane characteristics define the minimum and maximum dimensions the vane required to operate a given sensor.

Figure 5-8 illustrates how the mechanical characteristics of a vane operated position sensor are defined. The left and right operate and release characteristics are specified as the center of the round mounting hole of the sensor. As a result, dimensions a, b, c and d are specified individually as distances from this reference point.

The mechanical characteristics for a typical vane operated position sensor are shown in the table, Figure 5-9. Refer to Figure 5-8 for the definition of a, b, c and d. The first (dimensions) row in the chart lists the characteristics at room temperature (25°C) and their tolerances. The left-difference (b-a), right difference (d-c) and left-right difference (d-b or c-a) have been included because their tolerances are smaller than the differences calculated from a, b, c and d individually. The second row lists the additional tolerance increase over the temperature range of the sensor (-40° to +125°C, for instance).

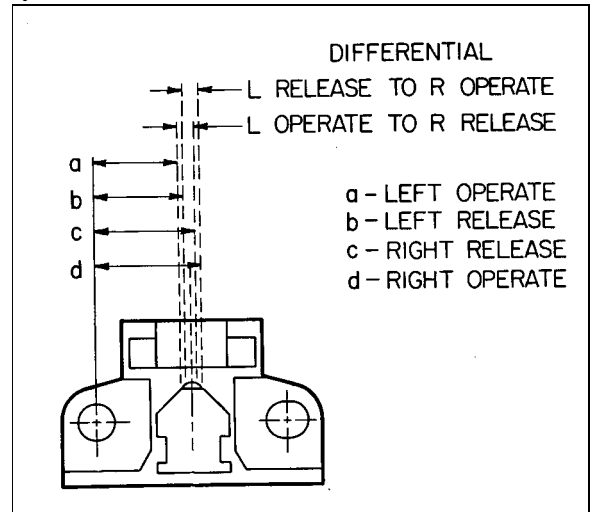

Figure 5-8 Reference points for mechanical characteristics

Temperature	Left			Right			L-R Diff.
	Operate a	Release b	Difference	Operate d	Release c	Difference	
25°C (77°F)	.390 ± .03	.410 ± .03	.020 ± .014	.510 ± .03	.490 ± .03	.020 ± .014	.100 ± .040
-40° to 125°C (-40° to 257°F)	± .040	± .040	± .010	± .040	± .040	± .010	± .070

Figure 5-9 Typical mechanical characteristics . . . Vane operated position sensor

Some typical dimensions for a multiple tooth vane are illustrated in Figure 5-10. The maximum thickness of a tooth is limited by gap width and required clearances. The amount of material necessary to shunt the magnetic field governs the minimum tooth thickness and tooth width. The minimum window width and tooth depth are specified to prevent adjacent vane material (teeth and frame) from partially shunting the magnetic field. The recommended range of tooth thickness and the corresponding minimum tooth width, window width, and tooth depth are shown in Figure 5-10.

Thickness	Minimum Tooth	Minimum Window	Minimum Tooth Depth
0.04"	0.40"	0.40"	0.40"
0.06"	0.25"	0.40"	0.37"

Figure 5-10 Typical multiple tooth vane dimensions

## Chapter 5 • Hall-based Sensing Devices

The vane operated position sensor may be used with a linear vane, as shown in Figure 5-11 to sense linear position.

Vane operated position sensors may be used with a circular vane to sense rotary position. Figure 5-12 shows a circular pie cut vane with windows cut from a sector. The window and tooth widths vary from a maximum at the vanes outer circumference to a minimum at its inner circumference. Since window and tooth widths vary, care must be taken to insure that the minimum specifications (Figure 5-10) are not violated.

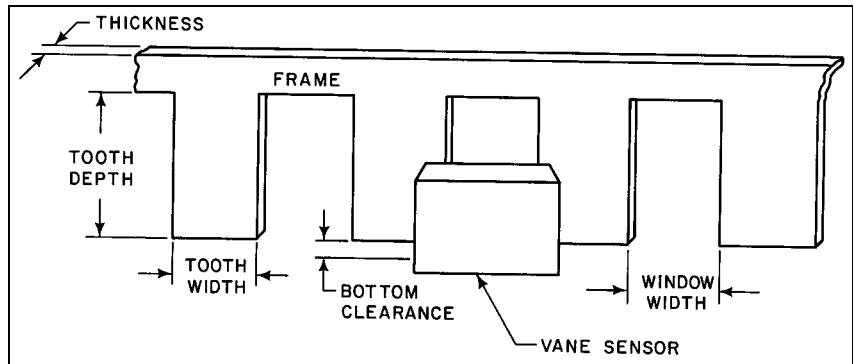

Figure 5-11 Vane operated linear position sensor

Another circular vane configuration is shown in Figure 5-13. This vane has uniform tooth and window widths, eliminating the drawbacks of a pie cut vane.

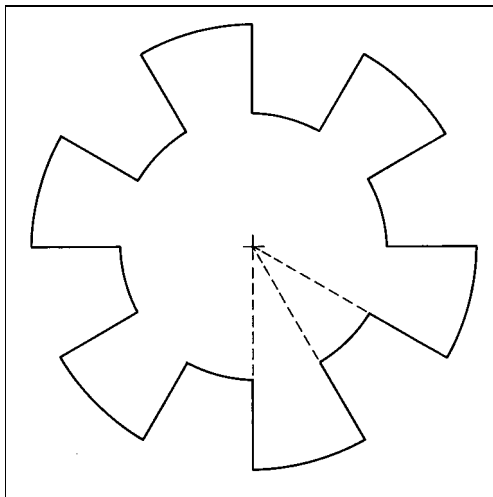

Figure 5-12 Circular vane with windows

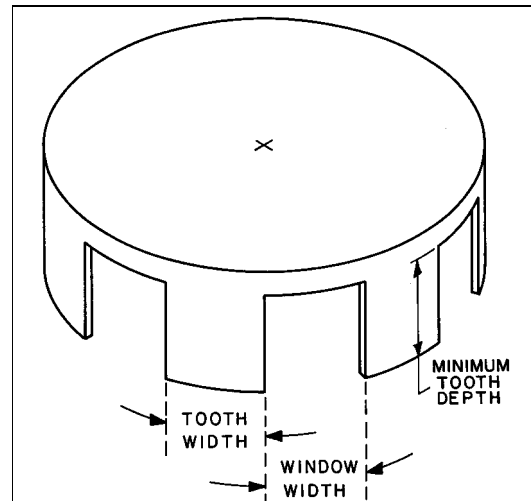

Figure 5-13 Uniform tooth and window vane

### Digital current sensors

A fast-acting, automatically-resetting current sensor can be made using a digital output Hall effect sensor. The current sensor is constructed using an electromagnet and sensor assembled as illustrated in Figure 5-14. Both the electromagnet and the Hall effect sensor are rigidly mounted in a package. The current passing through the electromagnet coils generates a magnetic field which is sensed by the Hall sensor.

An overload signal could change state, from low to high or vice versa, when the current exceeded the design trip point. This signal could be used to trigger a warning alarm or to control the current directly by electronic means.

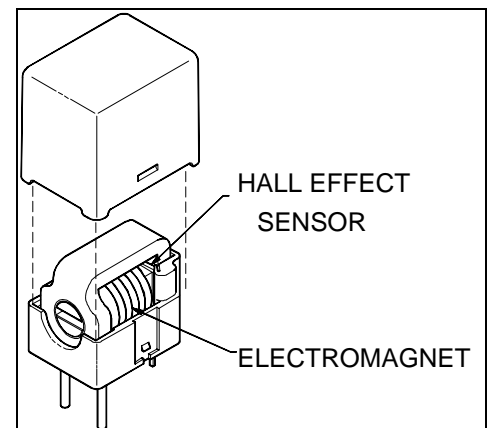

Figure 5-14 Typical digital current sensor

### Principles of operation

The operation of a current sensor depends on the use of an electromagnet to generate a magnetic field. Electromagnets are based on the principle that when a current is passed through a conductor, a magnet field is generated around it. See Figure 5-15. The flux density at a point is proportional to the current flowing through the conductor. If the conductor is formed into a coil, the magnetic field from successive turns of the coil add. As a result, the magnetic field from a coil is directly proportional to the product of the number of turns in the coil and the current flowing through the coil.

Conductors, coiled conductors or either of these in combination with pole pieces (magnetically soft materials) can be used as an electromagnet. Pole pieces are used in a current sensor, such as the one shown in Figure 5-16, to concentrate the magnetic field in a gap where a Hall effect sensor is positioned. The magnetic field in the gap is proportional to the current flowing through the coil.

For a digital output Hall effect sensor with operate and release points as indicated in Figure 5-17, the current sensor will turn ON when current  $I_2$  is reached and OFF when the current drops to  $I_1$ . Ideally the current sensor will turn ON at the moment  $I_2$  is reached. However, if the current level is changing rapidly, eddy currents (current induced by the time rate of change of flux density) will be induced in the pole pieces. In turn, these currents produce a magnetic field that opposes the input current, thus reducing the net flux density seen by the Hall effect sensor. The result is an apparent delay between the time  $I_2$  is reached and the output turns ON.

The same principles of operation apply when using a linear Hall effect sensor. Refer to Chapter 6 where design concepts for linear sensors are discussed.

### Sensor specifications

Typical operational characteristics of a digital output current sensors are shown in Figure 5-18. The direct current (DC) operate and release characteristics of a digital output current sensor are specified in terms of an operate current (within a tolerance), and a minimum release current.

Where a digital output current sensor is used to indicate a low current condition, the normal current will be greater than the operate level. Maximum continuous DC current specifies the largest continuous current that may be used in this type of application. Maximum coil resistance is used to calculate the voltage drop (insertion loss) across the coil and the power dissipated by the coil. Temperature stability is used to calculate the shift in operate and release characteristics of the sensor as a function of temperature.

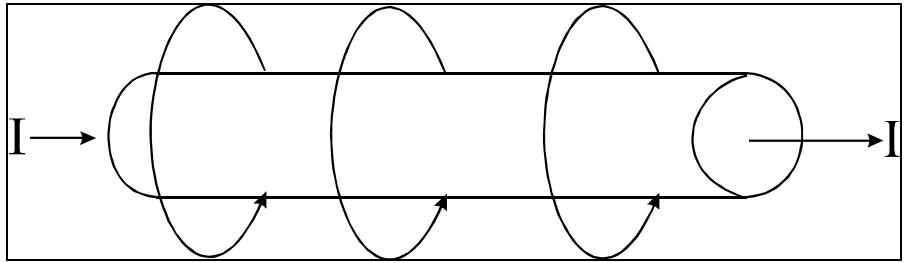

Figure 5-15 Electromagnetic field

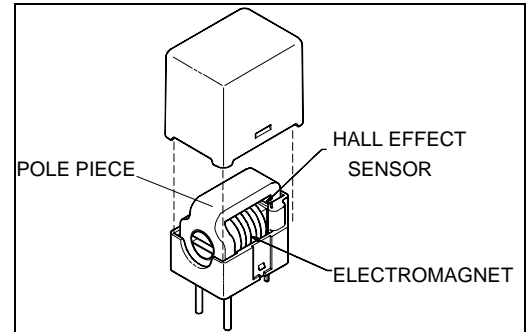

Figure 5-16 Current sensor with pole pieces

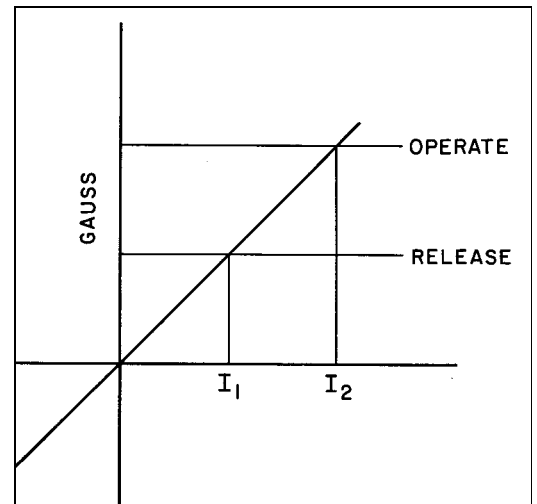

Figure 5-17 Current sensor transfer function

Figure 5-18 Typical digital output current sensor specifications

DC Current				
Operate	Min. Rel.	Max. Cont.	Max. Coil Resistance	Temperature Stability
5 ± .25	3.8 A	25°C/20 A	5 mΩ	± .008 A/°C

**Linear current sensors**

A current sensor with an analog output can be made using a linear Hall effect sensor. The current sensor is constructed using a ferrite or silicon steel core and a Hall effect IC as shown in Figure 5-19. Both the core and the IC are accurately mounted in a plastic housing. The current passing through the conductor being measured generates a magnetic field. The core captures and concentrates the flux on the Hall effect IC. The linear response and isolation from the sensed current makes linear current sensors ideal for motor control feedback circuits.

The voltage output of the Hall effect IC is proportional to the current in the conductor. The linear signal accurately duplicates the waveform of the current being sensed.

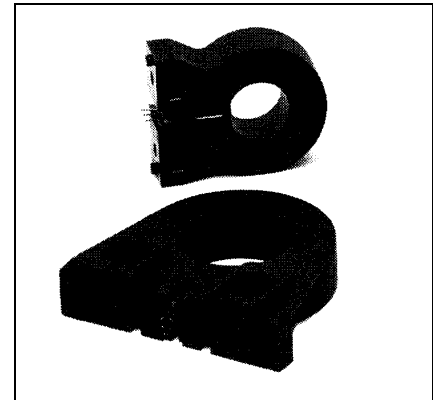

Figure 5-19 Typical linear current sensor

**Principles of operation**

Linear current sensors monitor the gauss level of the magnetic field created by a current flow, not the actual current flow. The current being measured is passed through a flux-collecting core that concentrates the magnetic field on the Hall effect sensor. The waveform of the sensor voltage output will trace AC or DC waveforms of the measured current. The through-hole design electrically isolates the sensor and ensures that it will not be damaged by over-current or high voltage transients. It also eliminates any DC insertion loss.

The Hall effect sensor is a ratiometric device. The output voltage of the sensor will be half of the supply voltage ( $V_{CC}$ ) when the current in the conductor being measured is zero. The output voltage range is 25% of the supply voltage up to 75% of the supply voltage ( $0.25 V_{CC} < V_{out} < 0.75 V_{CC}$ ). When the current is flowing in the positive direction, the output voltage will increase from the null ( $V_{CC}/2$ ) towards  $0.75 V_{CC}$ . See Figure 5-20 for an example of a linear current sensor output.

When current is flowing in the opposite direction, the voltage output decreases from the null towards  $0.25 V_{CC}$ . Since the sensor is ratiometric, sensitivity is also a functions of  $V_{CC}$ .

Current sensors are best used towards the maximum end of the sensed range. This will help with noise. To increase the current measured to a level near the maximum, the number of times the wire is passed through the core can be increased. For example, a 50 amp peak sensor could be used to measure a 10 amp peak conductor by looping the wire through the sensor aperture five times. Count the number of turns as the number of wire cross-sections in the core hole. The position of the wire in the core is not a major contributor to measurement error. The sensitivity of the sensor also increases as the number of times the conductor is passed through the hole.

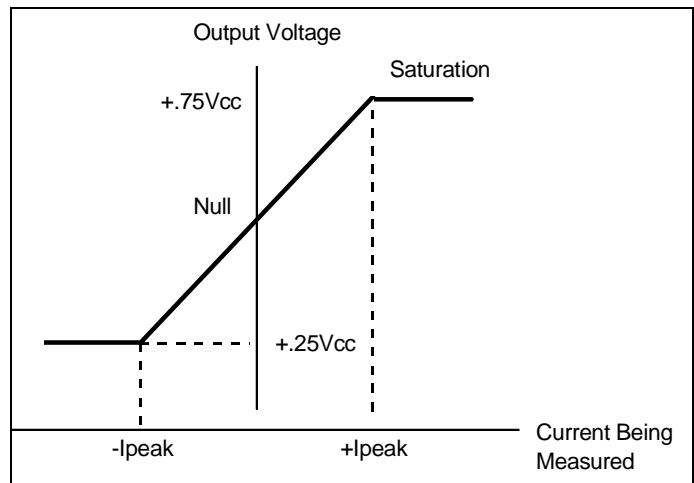

Figure 5-20 Linear current sensor ideal output

As with Hall effect sensors, current sensors are subject to drift because of temperature changes. Linear current sensors can have their null offset voltage and the sensitivity change with temperature. Sensors with ±0.02 to ±0.05 percent per degree C offset shift are common. The change in voltage offset from temperature shift can be calculated as:

$$\Delta V_{\text{offset}} = \pm 0.0002 * \Delta \text{Temp} * V_{\text{offset @ 25C}} \quad (5-1)$$

Values of the sensitivity shift are ±0.03 %/C typically. The change in sensitivity can be calculated in the same way as the null shift.

The flux collector is typically a ferrite or silicon-steel core. Core material is selected on the basis of saturation and remanance. At some point, a core material will not collect additional flux and is defined to be saturated. When this happens, the sensor will no longer supply an increasing voltage output to increasing conductor field strength. Remanance is the residual flux that is present in the core after the excitation of the current sensor. The remanance will create a shift in the null offset voltage. The air gap in the core also has an effect on the saturation point. By varying the width of the gap, the level of current that produces the amount of gauss necessary to saturate the sensor is varied.

Typical sensor characteristics are provided in Figure 5-21

Supply Voltage (Vdc)	Supply Current (mA max)	Offset Voltage (Volts 2%)	Offset Shift (%/ c)	Response Time (µsec)
6 to 12	20	V <sub>cc</sub> /2	± 0.02	3

Figure 5-21 Typical linear output current sensor characteristics

### Closed Loop Current Sensors

Another application of Hall effect technology in current sensing is the closed loop current sensor. Closed loop sensors amplify the output of the Hall effect sensor to drive a current through a wire coil wrapped around the core. The magnetic flux created by the coil is exactly opposite of the magnetic field in the core generated by the conductor being measured (primary current). The net effect is that the total magnetic flux in the core is driven to zero, so these types of sensors are also called null balance current sensors. The secondary current in the coil is an exact image of the current being measured reduced by the number of turns in the coil. Passing the secondary current through a load resistor gives a voltage output.

The closed loop current sensor has some very desirable characteristics. The feedback system responds very fast, typically less than one microsecond. Frequency response bandwidth is typically 100 kHz. Closed sensors are very accurate with linearity better than 0.1%. All of these specifications exceed what is possible with open loop linear sensing. However, the higher cost, larger size, and increased supply current consumption of the closed loop sensors must be balanced with the application’s requirements for accuracy and response.

### Principles of Operation

The closed loop sensor has several more components in addition to the core and Hall effect sensor used in the open loop linear sensor. The feedback electronics including an operational amplifier and the coil are the significant additions. Figure 5-22 shows the construction of a typical closed loop sensor.

The primary current being measured ( $I_p$ ) creates a magnetic flux in the core just as in the open loop linear sensor. The core is made up of thin pieces of steel stacked together to give high frequency response. The Hall effect sensor in the core gap measures the amount of flux in the core. As with the open loop sensor, the voltage output of the Hall effect sensor is proportional to the current  $I_p$ . The output of the Hall sensor is amplified in the compensation electronics. The current output of the compensation electronics ( $I_s$ ) creates a second magnetic field in the coil. The magnitude of this secondary field is the product of current  $I_s$  times the number of turns in the coil ( $N_s$ ). The magnetic flux from the secondary coil cancels out the flux from the primary to zero. The feedback system of the current sensor is shown in Figure 5-23.

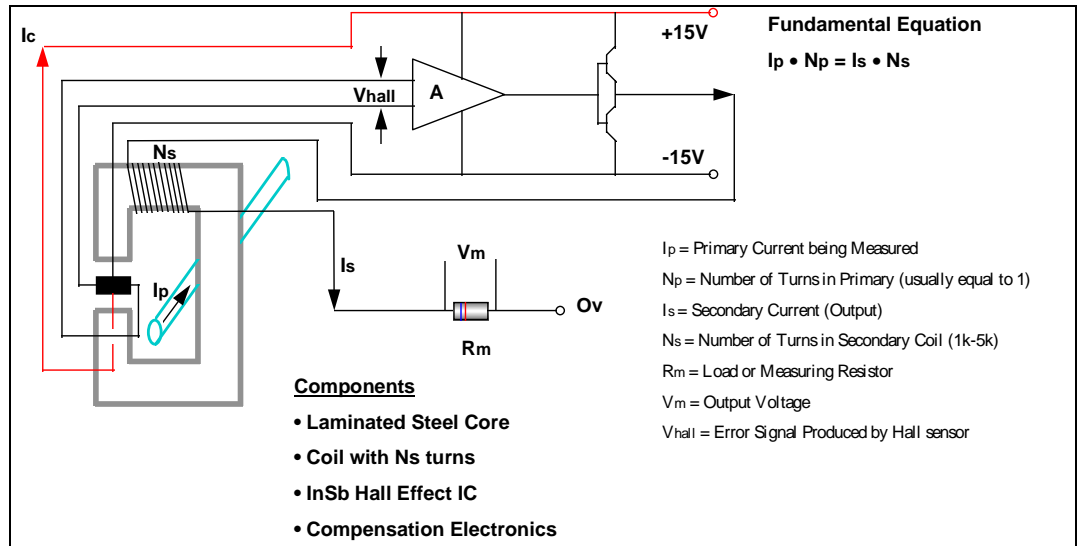

Figure 5-22 Closed loop current sensor construction

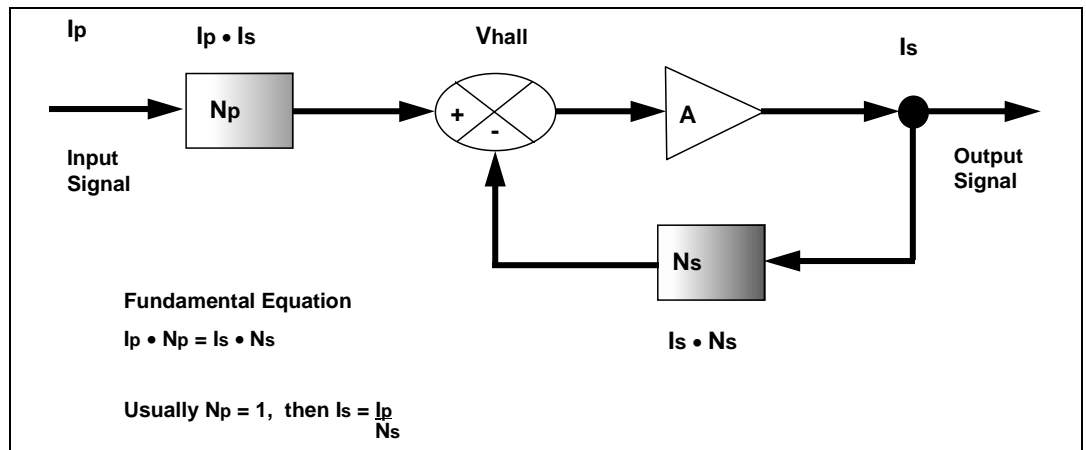

Figure 5-23 Block diagram showing feedback system

The output of the closed loop current sensor is the secondary current  $I_s$ . When the current is passed through a measuring or load resistor, the output becomes a voltage that is proportional to the primary current being measured. DC, AC, and impulse currents can be accurately measured and waveforms duplicated. The selection of the load or measuring resistor has a major impact on the maximum current that can be sensed. The maximum measuring range of  $I_s$  is determined by the supply voltage available and the selection of the measuring resistor according to the following equation:

$$I_s = \frac{V_{supply} - V_{ce}}{R_m + R_s}$$

where:

$V_{supply}$  = the supply voltage available (in Volts)

$V_{ce}$  = the saturation voltage of sensor output transistors (typ. 3.5V max.)

$R_m$  = the measuring or load resistor value ( $\Omega$ )

$R_s$  = the resistance of the internal secondary coil  $N_s$  ( $\Omega$ )

The maximum current that can be sensed will increase with the selection of a lower load resistance. See Figure 5-24 for an example output range of a 300 amp nominal closed loop current sensor.

The output current is not exactly zero when the primary current  $I_p$  is zero. There is a small offset current from the operational amplifier and Hall effect sensor. This current is typically less than  $\pm 0.2$  mA. Accidental distortion of the offset can occur if the magnetic circuit is magnetized by a high DC current when the sensor is not powered up. This value is usually limited to 0.5 mA. Finally, there will be a drift in offset current with temperature changes. The drift is caused by the operational amplifier and the Hall sensor changing values of temperature. The offset error is typically limited to  $\pm 0.35$  mA.

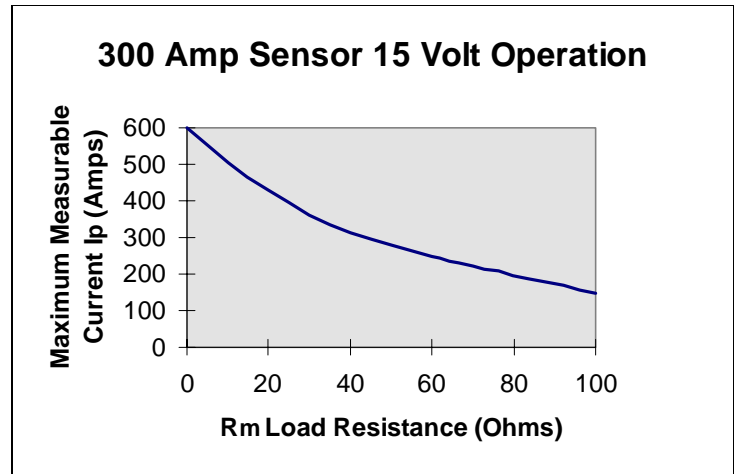

Figure 5-24 300 Amp sensor output range

### Mechanically operated solid state switches

The mechanically (plunger) operated solid state switch is a marriage of mechanical switch mounting convenience and solid state reliability. These switches consist of a magnet attached to a plunger assembly and a Hall effect sensor mounted rigidly in a package as shown in Figure 5-25. From an external viewpoint, the solid state switch has characteristics similar to a traditional mechanical snap-action switch. High reliability, contactless operation, and microprocessor compatible outputs are the primary distinguishing features.

### Principles of operation

The solid state switch shown in Figure 5-25 employs a magnet pair to actuate a digital output Hall effect sensor. These magnets are mounted in the bipolar slide-by mode, to provide precision operate and release characteristics.

For the magnet pair shown in Figure 5-25, the north pole is normally opposite the sensor maintaining the switch in a normally OFF state. When a plunger is depressed, the south pole is brought into proximity to the sensor, turning it ON. This type of switch is referred to as normally OFF.

A normally ON switch will result from reversing the magnet pair. The south pole is normally opposite the digital output Hall effect sensor, maintaining the switch in a normally ON state. When the plunger is depressed, the north pole is brought near the sensor, turning it OFF.

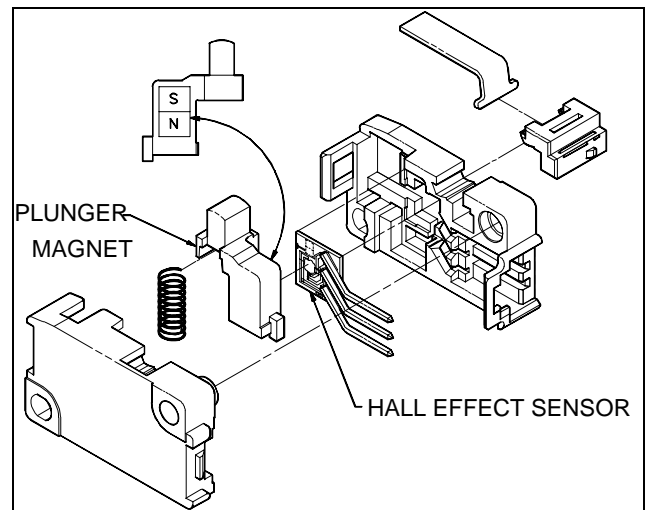

Figure 5-25 Typical solid state switch (normally OFF)

### Switch specifications

The operating characteristics of a typical mechanically operated solid state switch are shown in Figure 5-26. These characteristics are defined below.

<b>Pre-travel</b>	The distance the switch plunger moves from the free position to the operating point			
<b>Operating point</b>	The position of the plunger, relative to a fixed point on the switch, where the sensor will change state			
<b>Over-travel</b>	The distance the plunger may be driven past the operating point			
<b>Differential travel</b>	The distance between the switch's operating point and release point			
<b>Operating force</b>	The mechanical force necessary to depress the plunger			
<b>Pre-travel (max.)</b>	<b>Operating Point</b>	<b>Over-travel (min.)</b>	<b>Differential Travel (max.)</b>	<b>Operating Force (ounces)</b>
2,16 mm .085 in.	14,73 mm .580 in.	1,02 mm .040 in.	0,30 mm 012 in.	.35 +.18 (-.14)

Figure 5-26 Typical solid state switch operating characteristics

Detailed information on the use of precision switches can be found in MICRO SWITCH General Technical Bulletin No. 14, Applying Precision Switches, by J. P. Lockwood.

### Gear Tooth Sensors

A gear tooth sensor is a magnetically biased Hall effect integrated circuit to accurately sense movement of ferrous metal targets. An example of an assembled gear tooth sensor is shown in Figure 5-27.

The IC, with discrete capacitors and bias magnet, is sealed in a probe type, non-magnetic package for physical protection and cost effective installation. See Figure 5-28 for typical construction of a gear tooth sensor and wiring diagram.

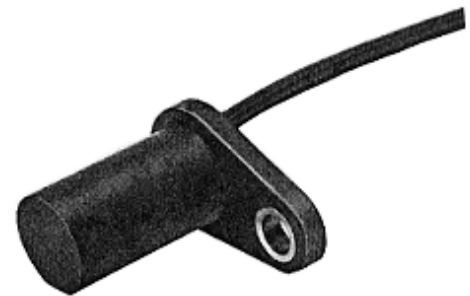

Figure 5-27 Gear tooth Hall effect sensor

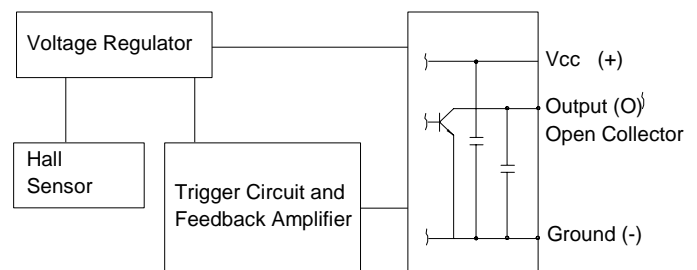
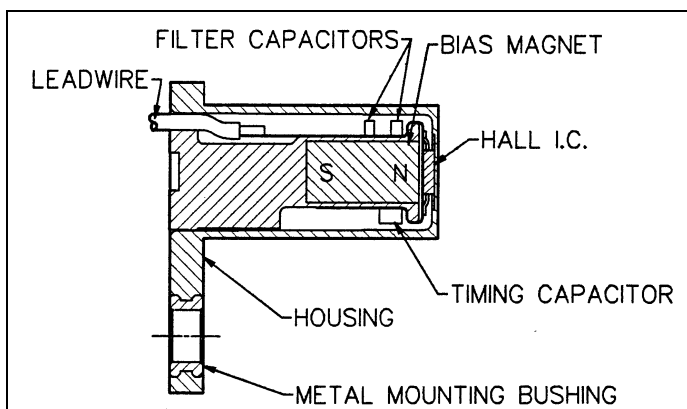

Figure 5-28 Gear tooth sensor construction and wiring diagram



### Principles of Operation

As a gear tooth passes by the sensor face, it concentrates the magnetic flux from the bias magnet. The sensor detects the change in flux level and translates it into a change in the sensor output. The current sinking (normally high) digital output switches between the supply voltage and saturation voltage of the output transistor. See Figure 5-29 for sensor output.

A thin film laser-trimmed resistor network in the preamplifier/trigger circuit is used to set and control the Hall element offset voltage and operate point. The sensor output is an open collector switching transistor, which requires a pull-up resistor.

A feedback circuit is integrated into the silicon IC and is used to reduce the effects of temperature and other variables. It uses a discrete capacitor to store a reference voltage that is directly proportional to the no-tooth magnetic field strength. This design requires that one target space must be moved past the sensor on power up to establish the reference voltage. The trigger circuit uses this voltage to establish the reference level for the operate point.

When the magnetic field sensed by the Hall element changes by a pre-defined amount, the signal from the Hall element to the trigger circuit exceeds the trigger point and the output transistor switches ON (low). The trigger circuit switches the transistor output OFF (high) when the Hall signal is reduced to less than 75% of the operate gauss.

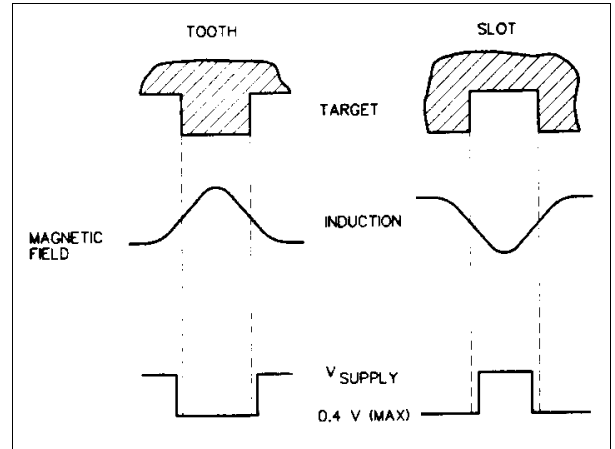

Figure 5-29 Sensor output (with pull-up resistor added to output circuit)

### Target Design

The optimum sensor performance is dependent on the following variables to be considered in combination:

- Target material, geometry, and speed
- Sensor/target air gap
- Ambient temperature
- Magnetic material in close proximity to the sensor and target

Figures 5-30, 5-31, and 5-32 show some of the typical tradeoffs involved with these variables. The operate point is defined as the distance from the leading edge of a tooth to the mechanical center of the sensor where the output changes from a high to a low voltage state. It is expressed in angular degrees.

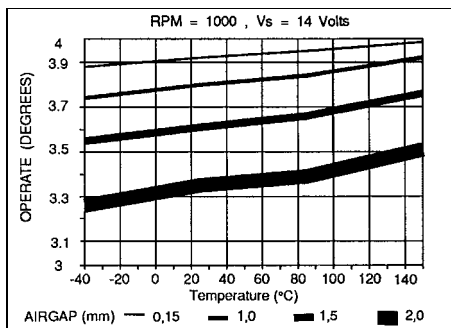

Figure 5-30 Operate Point vs. Temperature

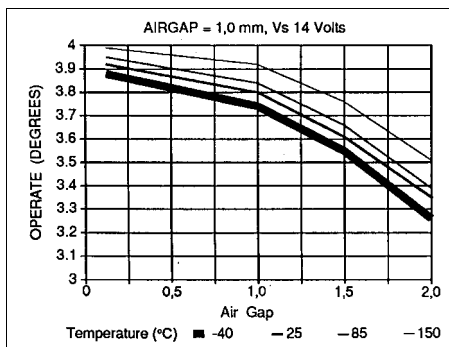

Figure 5-31 Operate Point vs. Air Gap

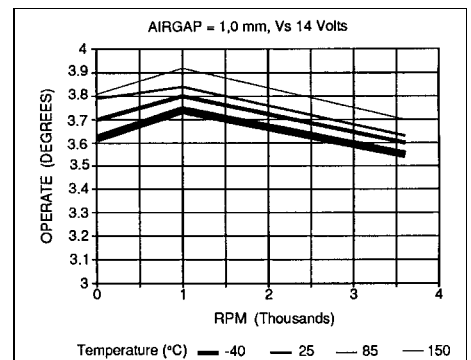

Figure 5-32 Operate Point vs. Target Speed

The following information will help in the design of a new target toothed wheel or to evaluate an existing target. The target should be made from a good magnetic material with less than 25 gauss residual magnetization. Cold rolled steels (1010-1018) are ideal. Other soft magnetic materials such as 430 stainless steel or sintered powdered metals may be used with a change in operating characteristics of less than 5%.

It is important to maximize the amount of magnetic flux available to the sensor; this will optimize the sensor's performance. See Figure 5-33 for target geometry. Increasing the tooth spacing width and the tooth height up to a certain point will maximize sensor performance. Increasing these dimensions beyond that will have little effect on the sensor.

A signature pulse can be used to indicate specific angular positions. There are two ways to provide a signature pulse: wide tooth and wide slot. Wide tooth is the simplest method. It is achieved by filling in the space between two or more teeth to make one large tooth. The advantage of this method is the spacing between the remaining teeth is uniform, insuring optimum performance.

The second method, wide slot, also achieves excellent results. A requirement for good target performance is that the magnetic level of the spaces between the teeth of the target be approximately the same. This can easily be done by decreasing the depth of the signature space to give it magnetic characteristics that are similar to those of the normal spaces. When this is done, the target performance will be the same as if the target had uniform spacing widths.

Target speed is the most critical detecting both the leading and trailing edge of a tooth. Gear tooth sensors can provide consistent indication of one or both edges. To achieve the highest accuracy and stability in such applications as speed sensing and counting, detection of the leading edge (operate point) is the most accurate.

At very low speeds, the output can change state due to time out (output goes high) prior to the trailing edge of the target passing the sensor. The time out is because of capacitive coupling of the feedback circuit on the IC and can vary with target geometry, air gap, and target speed. The output affects only the trailing edge (release point).

### Summary

In this chapter, the principles and specifications of Hall effect based sensors have been examined. In conjunction with the information presented in Chapter 4, the techniques necessary to apply sensors have been established. The next chapter brings together the information in this and previous chapters and demonstrates how it is applied.

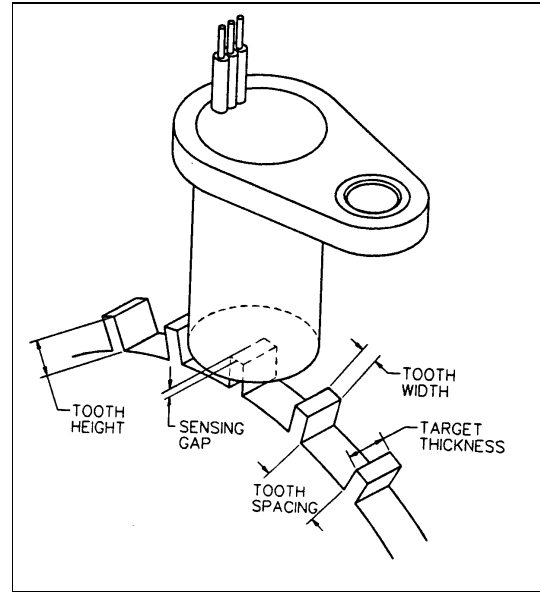

Figure 5-33 Target Geometry

# Applying Hall-effect Sensing Devices

Hall effect sensing devices can be used to sense many physical parameters, ranging from the direct measurement of a magnetic field to the detection of ocean currents. Although these applications vary in nature, the same design approach can be used. The beginning of this chapter addresses general design strategies. It begins with a requirement to sense some quantity through a fundamental concept.

The remainder of the chapter covers Hall effect as the particular technology used. It describes the various design phase approaches, procedures, alternatives and the factors to be considered when designing sensing devices using the Hall effect. The Hall sensor's input, output and magnetic characteristics are brought together and defined.

Using this chapter, a designer can choose the internal components (Hall effect sensor, magnetic system and the input and output interfaces) from manufacturer's data sheets or catalogs to provide the required electrical signal from the sensed quantity. This chapter, together with the next, Application Concepts, forms the basis for sensing device design.

## General sensing device design

Figure 6-1 illustrates the procedure for designing sensing devices using any sensing technology.

The first step in any sensing device design is to define what is to be sensed. The identification of the physical parameter (quantity) to be sensed is not always obvious. Measuring the rotation of an impeller blade is one approach to building a flow meter. In this case, it would be easy to assume what is to be sensed is the rotation of the impeller blade. In fact, fluid flow is the desired quantity to be sensed. The limiting identification of the impeller blade motion as the parameter to be sensed, reduces the possible design approaches and available technologies open to the designer.

In most cases, several methods of sensing a physical parameter can be identified. Each of these methods will consist of a conceptual approach with an associated technology. The conceptual approach describes how the sensing function might be implemented without considering the engineering details and component specifications. At this level of detail, some conceptual approaches can be immediately eliminated on the basis of cost, complexity, etc. Take, for example, a simple motor tachometer application. Although a laser-gyro could be used to sense rotary motion, it would be immediately removed from consideration because it is much too complicated for the design objective.

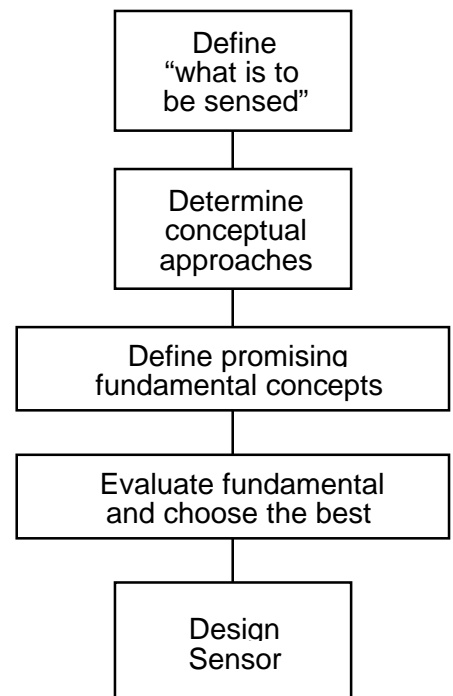

**Figure 6-1 General sensing device design approach**

## Chapter 6 • Applying Hall Effect Sensing Devices

It is important that the designer not limit the method of sensing a physical parameter to the obvious. Physical parameters can often be sensed using indirect methods. As an example, the requirement to sense temperature changes. An obvious approach would be to use a thermocouple since it is a temperature sensor. An alternate method of sensing temperature is shown in Figure 6-2.

In this example, an increase and/or decrease in temperature causes the bellows to expand or contract, moving the attached magnet. The corresponding change in magnetic field is sensed by the Hall effect sensing device. The end result is conversion of the temperature input to a measurable electrical field.

Once the most promising sensing techniques are identified, a decision must be made as to the concept which will be followed. In order to make this decision, the conceptual approach must be expanded into a fundamental concept (Figure 6-1). A fundamental concept includes the identification of input and output requirements, the major sensing device components, and the application requirements. With all requirements at hand, the resulting fundamental concept can be analyzed. The result of this analysis will be the choice of a concept for further development.

Consider a simple motor-tachometer application where each rotation of the motor shaft is to be detected. Two conceptual approaches are shown in Figures 6-3 and 6-4. The approach shown in Figure 6-3 consists of a ring magnet on the motor shaft and a radially-mounted digital output Hall effect sensor. As the ring magnet rotates with the motor, its south pole passes the sensing face of the Hall sensor with each revolution. The sensor is actuated when the south pole approaches the sensor and deactivated when the south pole moves away (see Chapter 3 for details). Thus, a single digital pulse will be produced for each revolution.

The conceptual approach shown in Figure 6-4 consists of a vane on the motor shaft with a phototransistor and LED pair mounted parallel to the shaft. As the vane rotates with the motor, the cut-out in the vane passes between the LED and the phototransistor, allowing light to pass. The phototransistor is turned ON for each rotation. Again, one pulse will be produced per revolution.

The details given in the two previous examples are insufficient to determine which one to develop. Input and output requirements must be considered. For example, what are the electrical characteristics of the output pulse required for the application (current, voltage, rise time, fall time, etc.)? The major components in the sensing device must be identified. If the required electrical characteristics are not met at the output of the phototransistor, what additional circuitry is required? The environmental requirements must also be identified. For example, if the sensing device is to be used in oil laden air, the optical approach would be discarded.

There are no universal step-by-step procedures that can be followed in the selection of a particular fundamental concept. Engineering judgment must be used. The strengths and weaknesses of each approach must be weighed. The features and

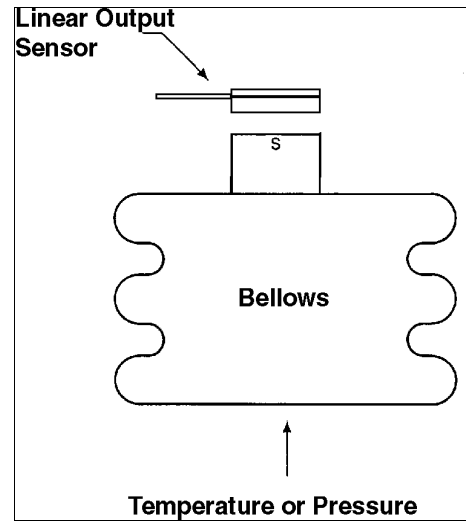

Figure 6-2 Hall effect based temperature sensor

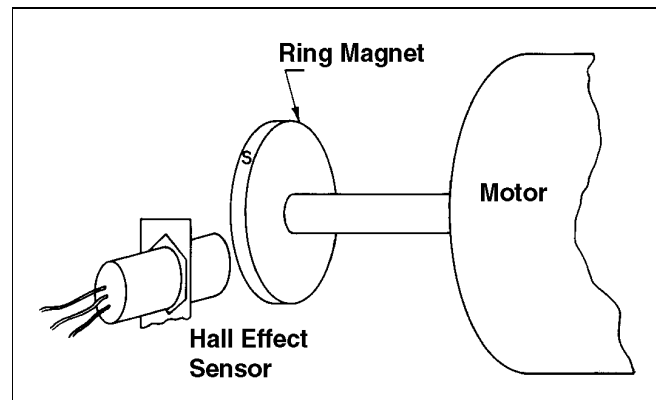

Figure 6-3 Hall effect conceptual approach

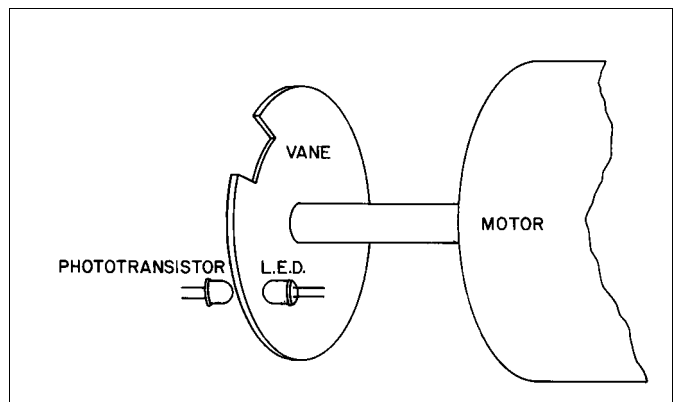

Figure 6-4 Optoelectronic conceptual approach

benefits of each technology must be evaluated with respect to the application. During the process of making tradeoffs, it is important that all key information be considered. Among the key considerations are:

- Overall cost
- Volume producibility
- Component availability
- Complexity
- Tolerance of part-to-part variations
- Compatibility with other system components
- Reliability
- Repeatability
- Maintainability
- Environmental constraints

MICRO SWITCH sensor products include complete position sensors, non-contact solid-state switches and current sensors. If one of these products fits the desired application, it will be the most cost-effective solution.

Although several of these considerations cannot be quantified until a detailed design is completed, they must, nevertheless, be weighed at this point.

Once a fundamental concept has been chosen, the detail sensing device design can begin. The remainder of this chapter will be devoted to the detailed design of sensing devices for which the fundamental concept includes a discrete Hall effect sensor or a sensor combined with a magnetic system in a single package.

### Design of Hall effect based sensing devices

Figure 6-5 illustrates the functional blocks that must be considered when designing Hall effect based sensing devices.

The design of any Hall effect based sensing device requires a magnetic system capable of responding to the physical parameter sensed through the action of the input interface. The input interface may be mechanical (most sensing devices) or electrical (current sensing devices). The Hall effect sensor senses the magnetic field and produces an electrical signal. The output interface converts this electrical signal to one that meets the requirements of the system (application).

The objective of the design phase is to define each of the four blocks that comprise the sensing device in Figure 6-5. Then determine all the components and specifications, mounting, interfacing and interconnection of these blocks with each other and with the system.

Not every Hall effect based sensing device requires all four functional blocks. A magnetic field sensor, for example, does not require a magnetic system or input interface. Other sensing devices have the magnetic system already designed and integrated into a package with the sensor chip. The design phase is somewhat simplified for these cases, but the objective is still the same.

The design phase begins with the fundamental concept chosen. Next, the detail configuration, specification and requirements for the application are defined. This is the system definition phase. Initial configurations and specifications for the sensing device are determined. Discrete sensing devices and sensing device packages will be treated separately, beginning with the concept definition. The final phase is detailed design. The approach to detailed design is broken into digital and linear.

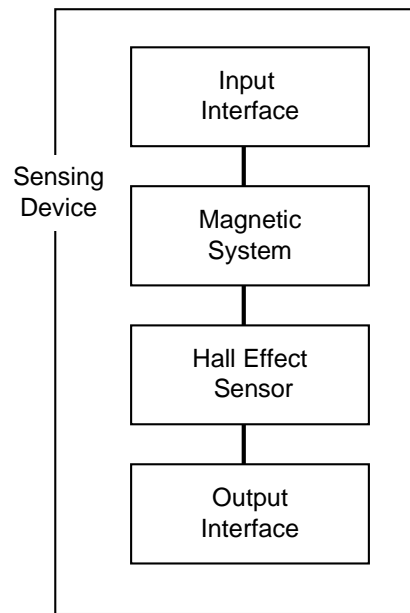

Figure 6-5 Hall effect based sensing device

### System definition

Once the fundamental concept has been chosen, system definition begins. System definition is the process in which detailed information is gathered about the application. This information includes configuration, specifications, and requirements of the application as they relate to the sensing device. Figure 6-6 shows the major steps in system definition.

First, the sensor input characteristics must be defined. These include:

- Range of input values
- Minimum and maximum rate of change of input values
- Factors which affect the input values such as time, temperature, etc.
- Safety factors
- Error sources
- System tolerances as they affect the input
- Environmental conditions

Next, the sensing device output requirements must be defined. These include:

- Electrical characteristics . . . current, voltage, etc.
- Output . . . logic level, pulse train, sum of pulses, etc.
- Definition of logic levels . . what voltage represents a logic 1
- Requirement for NPN (current sinking) or PNP (current sourcing) output
- Output level when sensing device is OFF
- Type of load . . . resistive, inductive, etc.
- Type of interconnection between the sensing device and the system, including length of cable, connector type, etc.
- System characteristics and constraints must also be defined. These include:
  - Location of sensing device
  - Space available for the sensing device
  - Weight limitations
  - Available power supplies for the sensing device
  - Basic sensing device requirements including accuracy, repeatability, resolution, etc.

The preceding lists of defined characteristics do not include all possible factors to be included in the system definition. Nor do all sensing device designs require that all these factors be considered. They are included here to indicate the scope of system definition.

The end result of system definition is to generate complete specifications for the sensing device.

### Concept definition . . .Discrete sensing devices

Concept definition is the process where the initial configuration and specifications for the Hall effect based sensing device are determined. The specifications are analyzed and the internal components (Hall sensing device, magnetic system, input and output interfaces) are chosen based on manufacturer's catalog data.

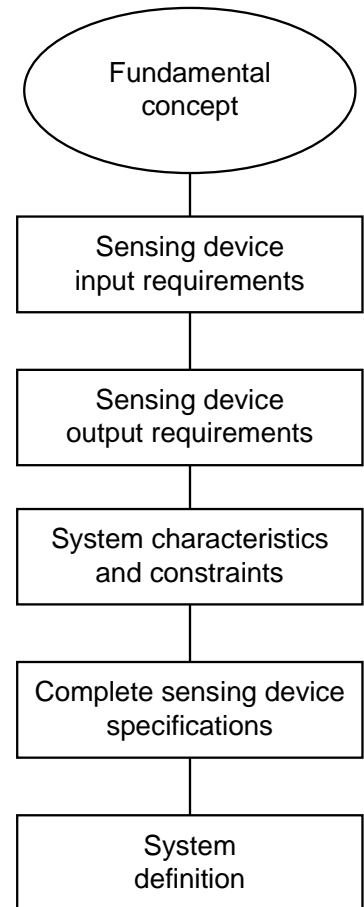

Figure 6-6 System definition

Figure 6-7 shows the principal steps in concept definition for sensing systems which are actuated by a magnet.

The first step in concept definition is to determine the sensing device component specifications. These include:

- The minimum and maximum gap between the magnet and the Hall effect sensor
- The limits of magnet travel
- Special requirements for the magnet such as high coercive force due to adverse magnetic fields in the system
- Mechanical linkages (if required)
- Sensor output type . . . NPN or PNP
- Operating temperature range
- Storage temperature range
- Various input/output specifications from the system specification

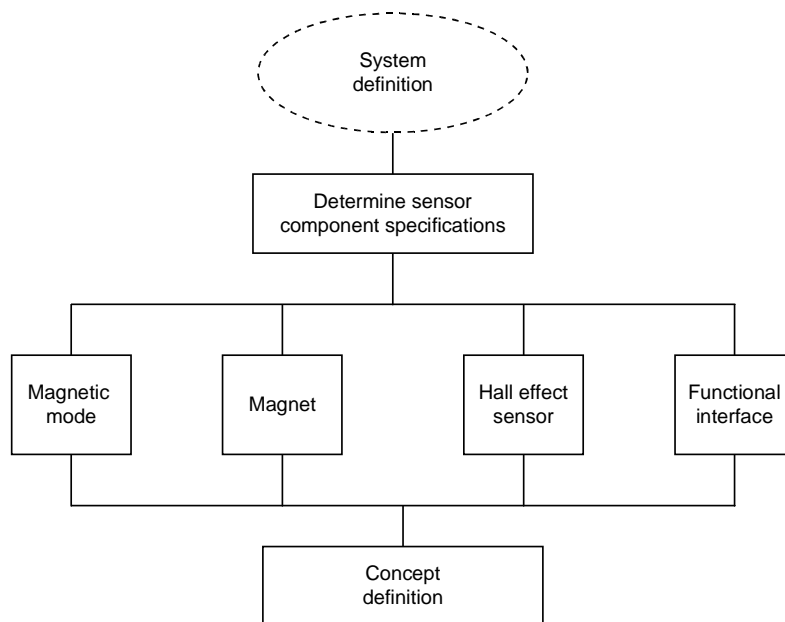

Figure 6-7 Concept definition - discrete sensing devices

The next step is to choose the magnetic mode, magnet, Hall effect sensor, and functional interface. These four items are shown in parallel (Figure 6-7) because the choices cannot be made independently. The required magnet strength is dependent on the gap and the limits of magnet travel (magnetic mode). The sensor is dependent on the strength of the magnetic field and therefore, on the magnetic mode and the magnet chosen. The functional interface is dependent on the sensor output type and electrical characteristics.

In order to assure that the characteristics of these four items are compatible, the designer must have an idea of the type of characteristics to be expected and the available components. Chapter 3 should be consulted for basic magnet information, as well as description of the most common modes. Appendices B and C contain additional magnet application data, including plots of gauss versus distance for various magnets. Chapter 2 describes Hall effect sensing devices, their power supply characteristics and transfer functions. Chapter 4 should be consulted for output characteristics and various interfaces. With this background, the designer can analyze catalog data and make an initial choice of a magnet, sensor and a functional interface. This choice will give a set of parameters upon which design trade-offs can be performed and detailed sensing device design can be initiated.

## Digital output Hall effect based sensing devices

### Design approach . . . Non-precision applications

In non-precision applications, the exact point of actuation is not a major consideration. Accuracy of these sensing devices is a function of reliability and large tolerances are acceptable for the operate and release points. A good design assures reliable operation under the following conditions:

- Unit-to-unit variations (as sensor components)
- Temperature extremes
- Power supply variations
- Electromagnetic interference (EMI)
- Ferrous material in the system
- Manufacturing and assembly tolerances

## Chapter 6 • Applying Hall Effect Sensing Devices

The design procedure for non-precision type sensing devices is illustrated in Figure 6-8. The concept definition previously determined is the basis for the design.

The first step is to develop the input interface (a concept for the input interface was determined by the fundamental concept, Figure 6-1). In this step, the detailed design and layout of the input interface is developed. For a simple position sensor, this may involve only the mounting and adjustment of the magnet and the basic Hall effect sensor. More complex applications may require the design of mechanical linkages, gearing, bellows, or cams that control the motion of the magnet.

Design of the input interface requires attention be given to good mechanical design practices. Consideration should be given to:

- Mounting magnets, pole pieces, Hall effect sensing devices, and flux concentrators
- Positioning and adjustments that may be required at assembly
- End play and run-out in rotary systems
- Thermal expansion characteristics where temperature extremes are encountered
- Tolerance build-up

The next step is to develop the output interface. In many applications, the output interface will be quite simple, consisting of a single pull-down or pull-up resistor. Other applications may require an electronic circuit be designed, for example, where the Hall effect sensor output must be buffered.

In Chapter 4, the electrical characteristics of Hall effect sensing devices are discussed and common output interfaces are examined in detail. When high electrical noise is present or when long electrical cables are used to connect the sensing device to the system, special attention should be given to potential noise problems. Standard reference books on electronic design, digital design or noise reductions techniques may be consulted to supplement the information in Chapter 4.

An initial design for all of the basic components of the sensing device is now available: the input interface, the magnetic system, the Hall sensor, and the output interface. The next step is to breadboard the sensing device, based on this initial design. The breadboard sensing device is a mock-up for making fine adjustments, minor modifications, or in some cases, major design changes.

Once the breadboard sensing device has been built, a decision must be made as to the need for accurate magnetic system curves. The magnetic system will present a range of flux density values to the sensing device as a function of the sensing device input. In the operate state, the maximum flux density of the magnetic system must exceed the maximum operate level for the Hall sensing device. Similarly, for a release condition, the magnetic system's minimum flux density must be less than the minimum release under the worse case conditions.

The excess flux density available for actuation is referred to as a guardband. A guardband of at least 100 gauss is desirable for non-precision applications. If the data used to design the magnetic system was not adequate to assure this guardband, then magnetic system data must be taken and magnetic curves plotted. Refer to Chapter 3, Magnetic Considerations and Appendix C for plots of gauss versus distance for various magnets.

A Hall element can be used to measure gauss versus distance. This can be used to measure the response of the magnetic system to the sensor inputs. From the resulting magnetic curves and sensing device specifications, the guardband can be

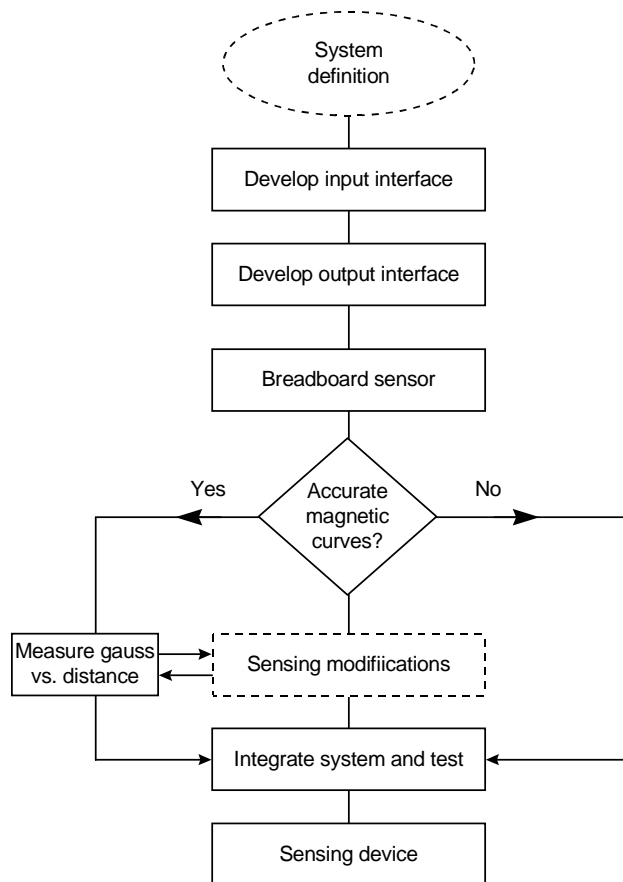

**Figure 6-8 Detailed design procedure - Non-precision digital output Hall effect based sensing device**



determined. If the guardband is inadequate, the design must be modified and new magnetic curves plotted. This is a repetitive process and continues until an adequate guardband is obtained.

If sensing device modifications are required to increase the guardband, refer to Figure 6-9.

Two approaches are available: the sensing device's sensitivity and/or the magnetic system field strength can be increased.

The sensing device's sensitivity can be increased by either selecting a sensing device with a lower operate gauss level, if available.

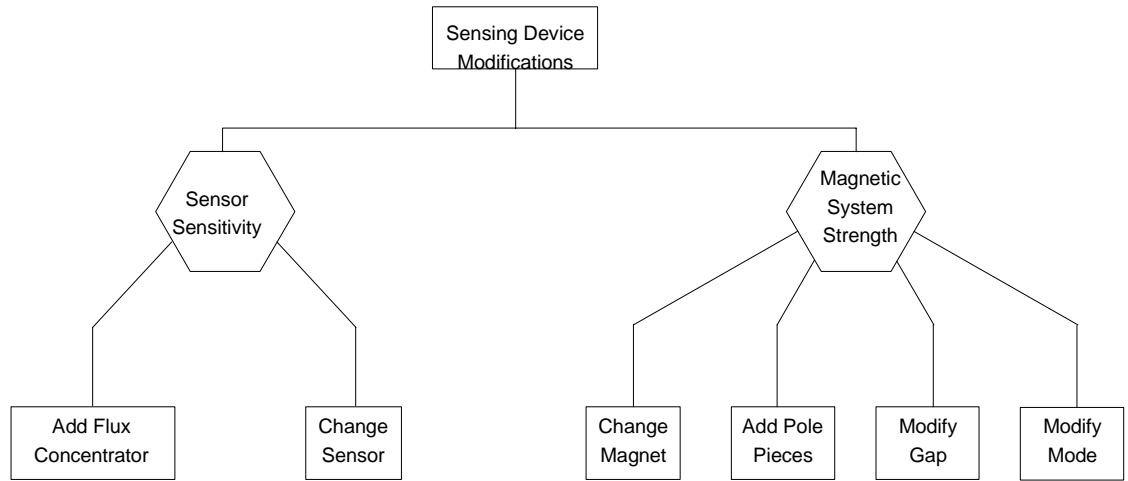

Figure 6-9 Sensing device modification options

The field strength of the magnetic system can be increased in a number of ways:

- The magnet can be replaced by one with a greater flux density
- Pole pieces can be added to concentrate the flux in the sensing area
- The gap between the magnet and the sensor can be decreased
- Secondary magnets can be added to the system to alter the mode

All of these techniques are discussed in Chapter 3. Note that any of these modifications may require a corresponding modification to the input interface.

The final step in the design approach for non-precision digital output sensing devices is to integrate the sensor into the system and test it to determine that all design objectives have been realized. Sensor integration involves the layout, location and mounting of all sensor components, interconnections, and electrical wiring. It also includes writing any procedures that may be required during final assembly. The result of successful testing of the integrated sensor is a finalized sensor design.

### Design approach . . . Precision applications

The design approach for precision digital output Hall effect based sensors is similar to the non-precision types (Figure 6-10) except that the exact point of operation and/or release is a prime consideration. The various design considerations previously covered apply again.

Reliable operation alone is not sufficient for precision digital type sensors. The operate and release points must be within specified tolerance limits. Two types of errors that will affect precision operation are:

- Unit-to-unit variations resulting from tolerances on components, manufacturing, and assembly
- Operation variations resulting from temperature changes, voltage transients, etc.

The effect of both of these error sources can be reduced by increasing the sensitivity of the sensing device to its input or reducing the sensitivity to error sources. Unit-to-unit variations can also be compensated by adjusting the sensor at assembly or by calibration of the completed sensor.

A detailed design procedure for precision digital output sensing devices is illustrated in Figure 6-10.

## Chapter 6 • Applying Hall Effect Sensing Devices

The initial steps, concept definition through breadboard device are the same as those covered by the non-precision types, Figure 6-8. An additional consideration to the design of the input interface is provision for adjusting the device to operate at a specified point (if required).

Once the breadboard sensing device has been built, it is necessary to measure gauss versus distance between the magnet and the sensor. Analysis of the resulting magnetic curve will determine the sensitivity of the device to changes in the sensor's operate/release characteristics. A portion of a typical magnetic curve is shown in Figure 6-11. (Refer to Appendix C for actual curves of gauss versus distance for various magnets offered by MICRO SWITCH Sensing and Control.)

To analyze this curve, let  $G_1$  be the operate gauss level of the sensor; the operate position will be  $d_1$ . If the operate level changes to  $G_2$  (due to unit-to-unit variations in the sensor, temperature change, etc.), then the operate position will be  $d_2$ . Thus, a sensor variation of  $(G_1 - G_2)$  will result in a sensing error  $(d_2 - d_1)$ . Note that:

$$d_2 - d_1 = \frac{(G_2 - G_1)}{(\Delta G / \Delta d)} \quad (6-1)$$

Where:

- $\Delta G / \Delta d$  is the slope of the magnetic curve at  $G_1$ . A steeper slope (larger  $\Delta G / \Delta d$ ) will result in a smaller sensing error.

The sensitivity of the sensing device to changes in the magnetic system can be determined by examining the magnetic curve in Figure 6-12. It shows a portion of a magnetic curve (Curve A) and the same curve after it has been shifted by a gauss level of  $\Delta G$  (Curve B).

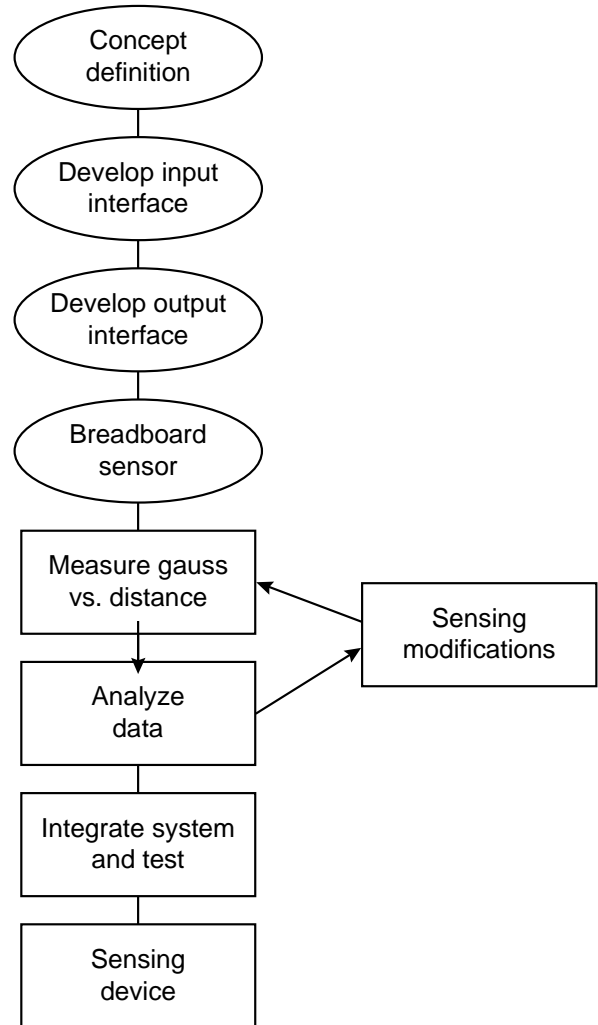

Figure 6-10 Detailed design procedure . . . Precision digital output Hall effect based sensors

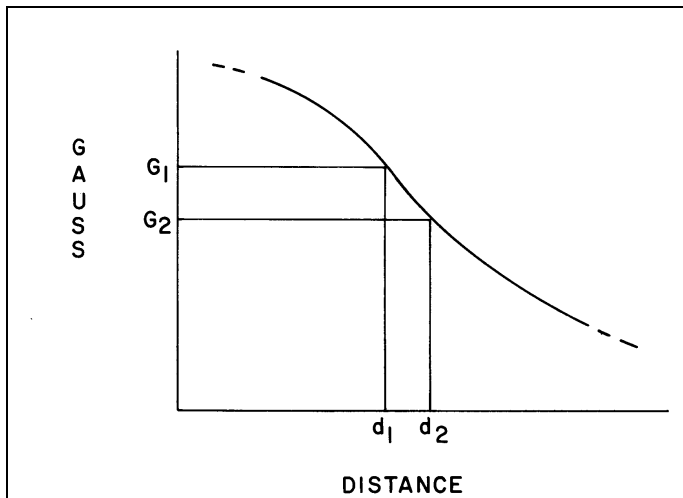

Figure 6-11 Operate gauss versus distance analysis

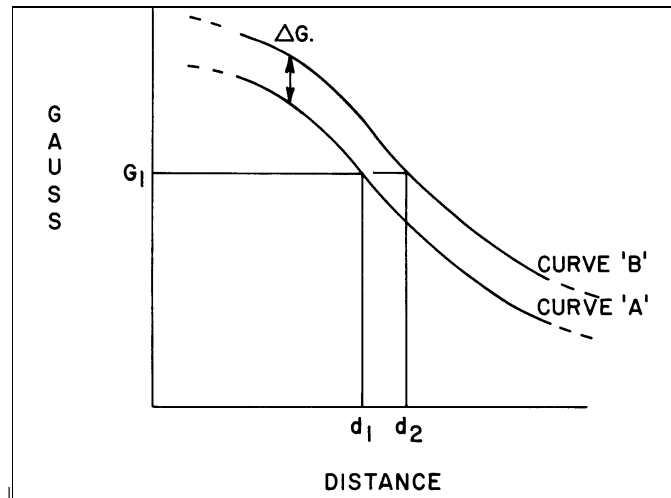

Figure 6-12 Effect of a shift in operating gauss

The sensing error,  $d_2 - d_1$ , is given by:

$$d_2 - d_1 = \frac{G}{(\Delta G / \Delta d)}$$

Again, a steeper slope will result in a smaller sensing error. The analysis step involves determining if the slope of the magnetic curve is sufficiently steep for the sensor's operate/release points to meet the tolerance limits of the sensor.

Several modification options are available if the analysis determines the tolerance limits of the sensor have not been met. One option could be changing the Hall effect sensor to one with different operate/release points so it will operate on a different portion of the magnetic curve. The magnetic curve itself can be changed by modifying the magnetic system. The methods shown for modifying the magnetic system are discussed in Chapter 3. A third alternative is to individually calibrate each sensor after assembly. Any of these changes may require a corresponding change to the input interface.

The final step in the design procedure (Figure 6-10) is to integrate the sensing device into the system and test to determine that all design objectives are met. Successful testing of the sensing device into the system completes the design.

### Linear output Hall effect based sensing devices

#### Design approach . . . Linear output sensors

The design approach for linear output Hall effect based sensors is similar to the digital output sensors previously covered. However, linear output sensors require a range of inputs to be considered, rather than a single operate/release point. The sensor response over the entire range of inputs must meet specifications.

A general procedure for designing linear output Hall effect based sensors is illustrated in Figure 6-13.

The initial steps, concept definition through breadboard sensor, are the same as previously discussed for digital output sensors. Additional considerations include:

- Transfer function
- Resolution and accuracy
- Frequency response
- Output conversion . . . e.g. analog to digital
- Output compensation

The overall transfer function for a linear output sensor describes its output for a given input value. A typical example of the transfer function for a linear output sensor is illustrated in Figure 6-14.

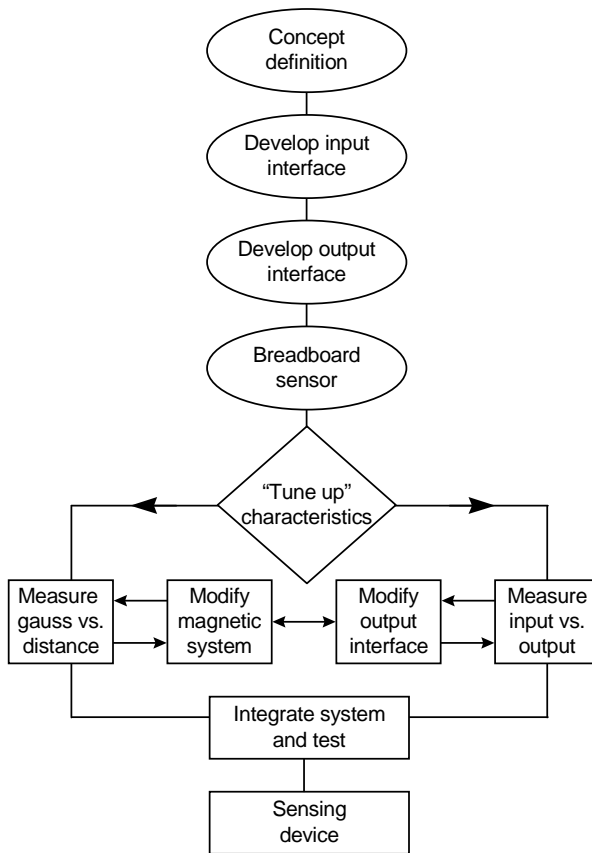

Figure 6-13 Design approach . . . Linear output sensors

In Figure 6-14, the sensor's input is represented by the symbol (X) and the output (Y). Since the transfer function is linear, it is described by its slope (m) and the point where it crosses the Y-axis by (b). This graphical representation of a linear transfer function can be stated as a mathematical equation.

Where:  

$$Y = mX + b \quad (6-2)$$

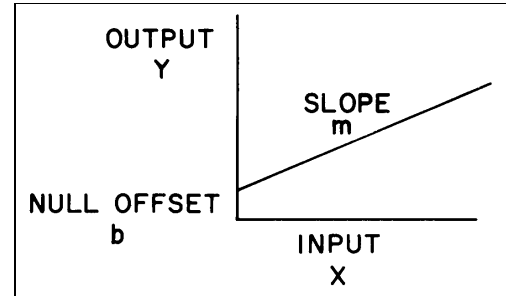

Figure 6-14 Linear transfer function

In chapter 2, the transfer function of a linear output Hall effect sensor was expressed as the relationship between magnetic field input and voltage output. In equation 6-2 (X) represents the magnet field input in gauss and (Y) the output in volts. Also in Chapter 2, the Hall effect sensor's transfer function was characterized by sensitivity, null offset and span. In this case, m-slope is the sensitivity and b-bias is the null offset. Span defines the output range of the Hall effect sensor. This parameter is necessary because the sensor will saturate outside this range and not be linear. In order to include this parameter, equation 6-2 should be written as:

$$Y = mX + B; X_{min} \leq X_{max} \quad (6-3)$$

When designing linear output Hall effect based sensors, the overall transfer function will depend upon each of the four functional blocks shown in Figure 6-5. If the transfer functions for each of these functional blocks (input interface and magnetic system, sensor and output interface) are linear, then their respective transfer function can be represented by:

$$B = m_M \cdot \text{Input} + b_M; \text{Input}_{(min)} \leq \text{Input} \leq \text{Input}_{(max)} \quad (6-4)$$

$$V_T = m_T \cdot B + b_T; B_{(min)} \leq B \leq B_{(max)} \quad (6-5)$$

$$\text{Output} = m_O \cdot V_T + b_O; V_{T(min)} \leq V_T \leq V_{T(max)} \quad (6-6)$$

Where:

- B = Flux density at the sensor
- $V_T$  = Sensor output voltage
- m = Sensitivity ( $m_M \cdot m_T \cdot m_O$ )
- $m_M$  = input interface and magnetic system
- $m_T$  = Hall effect sensor (sensor)
- $m_O$  = output interface
- b = Null offset ( $b_M \cdot b_T \cdot b_O$ )
- $b_m$  = input interface and magnetic system
- $b_T$  = Hall effect sensor (sensor)
- $b_O$  = output interface

By substituting for B in equation 6-4 and  $V_T$  in equation 6-5, the overall linear transfer function can be written as:

$$\text{Output} = m_S \cdot \text{Input} + b_S; \text{Input}_{(min)} \leq \text{Input} \leq \text{Input}_{(max)} \quad (6-7)$$

Where:

- $m_S = m_O \cdot m_T \cdot m_M$ ; overall sensitivity
- $b_S = (m_O \cdot m_T) b_M + (m_O \cdot m_T) b_T + b_O$ ; composite bias

Note that the input range in equation 6-7 is valid only if the input ranges in equations 6-5 and 6-6 are not exceeded. The input range is not the same as the safe operating range ( $B$  may be increased indefinitely without damage to the sensor). Rather, it is the range of values for which the transfer function describes the actual operation (within some tolerance). An important step in the design process is to assure compatibility of the input ranges of the four functional blocks, shown in Figure 6-5.

In equations 6-4 through 6-7, it was assumed that the transfer functions for each of the four functional blocks are linear. Linearity is always an approximation. No device or circuit is absolutely linear. The magnetic systems described in Chapter 3 were shown to be very non-linear. However, by limiting the input range to a region that the curve can be approximated by a straight line, linear transfer functions may be used.

Figure 6-15 illustrates how a portion (from  $\text{Input}_{(\min)}$  to  $\text{Input}_{(\max)}$ ) of a unipolar slide-by curve might be approximated by a straight line. It is important to include an analysis of the error that results from this approximation to assure the sensor's tolerance limits are not exceeded.

For some applications, the input range cannot be limited to a region for which the magnetic curve can be approximated by a straight line. For these cases, overall sensor linearity can be achieved by including a complementary non-linearity in the output interface. Since this process involves sophisticated electronic design, it is not within the scope of this book.

Once the breadboard sensor has been built, two options are available for tuning the sensor to the desired characteristics and specifications (refer to Figure 6-13). The magnetic system transfer function may be adjusted or modified. This option requires that the gauss versus distance (or current in the case of a current sensor) first be measured. Using the ratiometric linear Hall effect sensor for this measurement will isolate the characteristics of the magnetic system from those of the Hall effect sensor. (Refer to Appendix C.)

The second option involves adjusting or modifying the output interface to achieve the same results. For this option, overall sensor input/output characteristics should be measured. The output interface can then be varied electronically to compensate for differences between the sensor and its specification. It may be necessary to investigate both options in order to complete the sensor design.

The final step is to integrate the sensor into the system and perform a complete system test. This step, with successful testing, completes the sensor design.

### Design approach . . . Linear current sensors

The design approach for a linear current sensor is similar to the general approach for linear output sensors, as shown in Figure 6-13. However, the magnetic system will consist of a soft magnetic core with an air gap and a coil wrapped around the toroid core, forming an electromagnet (Figure 6-16). A linear output Hall effect sensor is positioned in the air gap to measure the flux density at that point.

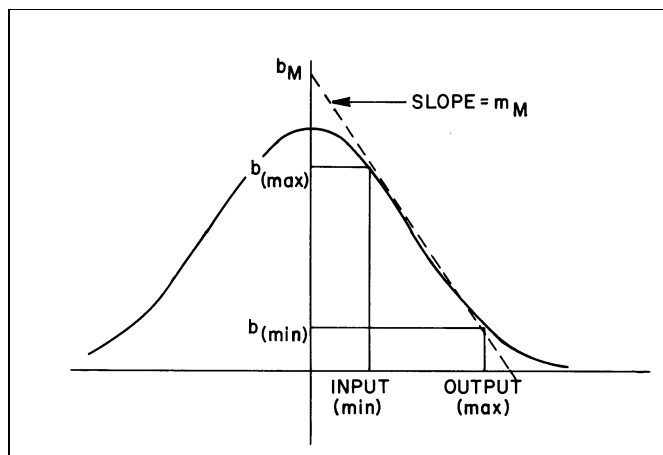

Figure 6-15 Linear approximation for magnetic curve

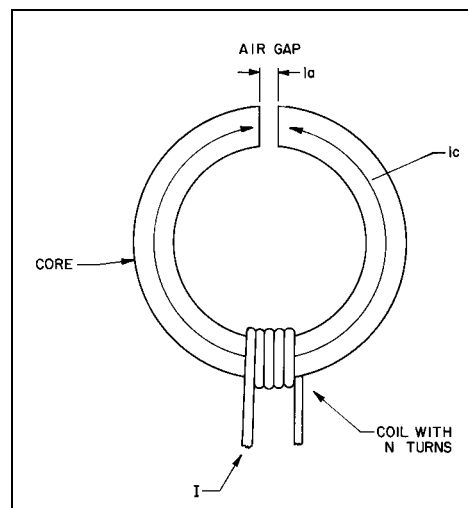

Figure 6-16 Simplified linear current sensor

Where:

$l_a$  is the length of the air gap in centimeters

$l_c$  is the mean length of the core in centimeters

$I$  (current) is flowing through a coil with  $N$  turns

If the air gap is narrow (when compared to the cross sectional area of the core), the flux can be considered to be concentrated in the air gap, and the flux density in the core will be equal to that in air. Applying Ampere's Law results in the transfer function.

$$B_a = \frac{0.4\pi\mu_c NI}{l_c + \mu_c l_a} \quad (6-8)$$

Where:

$B_a$  is the flux density (gauss) in the air gap

$\mu_c$  is the relative permeability of the core

For simplicity, the equation can be rewritten as

$$B_a = m_M \cdot I$$

Where:

$$m_M = \frac{0.4\pi\mu_c \cdot N}{l_c + \mu_c l_a} \quad (6-9)$$

Note this equation is valid only if the flux density in the core has not reached saturation level. That is:

$$-B_{sat} \leq B_a \leq B_{sat} \quad (6-10)$$

Where:

$B_{sat}$  is the core saturation flux density

Now consider the linear output Hall effect sensor described in Chapter 2 with a transfer function:

$$V_T = m_T \cdot B + b_T; -400 \leq B \leq +400 \quad (6-11)$$

Where:

$$m_T = 6.25 \cdot 10^{-4} \cdot V_S \quad (6-12)$$

$$b_T = 0.5 \cdot V_S \quad (6-13)$$

$V_S$  = the supply voltage to the Hall effect sensor

The two transfer functions (equations 6-8 and 6-10) can be combined to give the overall sensor transfer function:

$$V_O = (m_T \cdot m_M) \cdot I + b_T \quad (6-14)$$

Design of the current sensor then involves:

Choosing a core such that  $B_{sat}$  is much greater than 400 gauss

Choosing  $l_a$  and  $N$  so that  $m_M \cdot I_{max} \leq 400$  gauss and  $m_M \cdot I_{min} \leq -400$  gauss

Choosing  $V_S$  so that  $m_T \cdot m_M$  yields the desired overall sensitivity if no output signal conditioning (output interface) is to be used

Other design factors must be considered when designing current sensors. The thermal dissipation of the coil and its insertion loss must be considered when choosing the wire size and the number of turns. Provision for high overcurrents may require the air gap be supported by a non-magnetic material to prevent collapse of the gap and core breakage. Output signal conditioning may be required, such as bias voltage removal, amplification, filtering, etc.

Also, eddy currents are an error source in AC current sensor design and in DC current sensor design when high ramp speeds from one DC level to another must be measured. Eddy currents are induction currents resulting from the time rate of change of flux density. The eddy currents, in turn, produce magnetic flux with an opposing polarity. Thus, the net flux density is reduced. Eddy currents create errors that appear as magnitude errors, time delays (phase lags), and thermal heating effects. Minimizing eddy currents requires careful choice of core material and the core design.

The final step in the design approach for a current sensor is to integrate it into the system and perform a complete system test. This step, with successful testing, completes the design.

## Sensor packages

### Design approach

Designing sensor packages using Hall effect sensors that include an integral magnetic system is straight forward. Since the magnetic system and transducer are already combined, no additional magnetic design is required. All that remains is to select the appropriate assembly along with determining the required input and output interfaces. Refer to Chapter 5 for operating principles and specifications for sensor packages.

The first steps, defining a fundamental concept and determining the system definition, are identical to sensors using discrete Hall effect devices. The discussion for designing sensors using Hall effect transducers (that are combined with a magnetic system) begins with concept definition. The principle steps are shown in Figure 6-17.

The sensor specifications were determined during system definition and are analyzed to determine the required sensing device package, as well as the functional characteristics and specifications for the input and output interfaces. This step is a simplification of the corresponding step for discrete sensing devices (Figure 6-7). Chapter 5 should be reviewed for the characteristics and specifications of sensing device packages. Chapter 4 should be consulted for the electrical characteristics and output interfaces. With this background, the designer can make an initial choice of transducer package and functional interface. This choice will give a set of parameters upon which design trade-offs can be performed and detailed sensor design can be initiated.

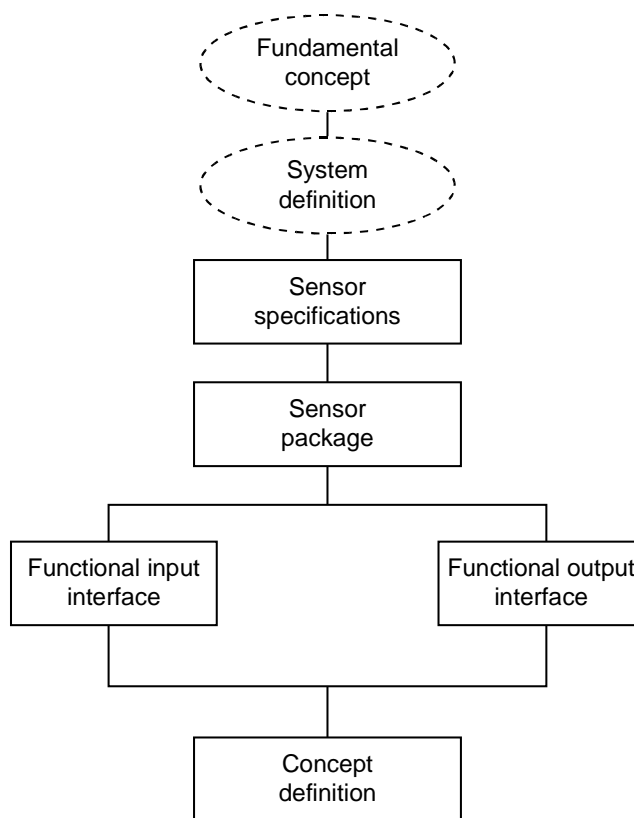

Figure 6-17 Concept definition - Sensing Device packages

### Design approach . . . Vane operated sensors

The design of sensors based on vane operation involves designing the vane, determining methods for mounting and adjusting the initial position, and designing the output interface. Chapter 5 should be reviewed for operational characteristics and parameters of the vane sensor. The electrical characteristics of vane sensors and common output interfaces are examined in Chapter 4.

Vane operated position sensors have steep magnetic curves and may be used for precision and/or non-precision applications. However, these devices are not specified in terms of their magnetic characteristics, but rather of their operate and release position and associated tolerances. This manner of specification greatly simplifies the analysis of accuracy and subsequent design.

One important factor that limits the range of applications is the sensors' magnetic attraction to the vane. Since this sensor contains a magnet, and the vane must be made of ferromagnetic material, there is an attractive force between the two. (As the vane tooth approaches the sensor, this force pulls the vane toward the sensor. As the vane tooth leaves the sensor, this force tries to restrain the motion of the vane. While the vane is in the gap, this force will tend to pull the vane tooth off center.) As a result a vane operated position sensor should not be used in applications where the force driving the vane is small or where the vane cannot be mounted rigidly enough to move through the sensor gap without being pulled off center.

A design procedure for sensors which use a vane is illustrated in Figure 6-18.

With the concept definition as the basis for the design, the first step is to design the vane. Important considerations are:

- Vane material
- Vane thickness
- Shape of tooth and window
- Dimensions and tolerances

The material used for the vane must be magnetically soft and free of any magnetization. A good choice is low carbon steel which has been fully annealed. The constraints on vane thickness are discussed in Chapter 5 as is the shape of tooth and window. The dimensions and tolerances of the vane are subject to the constraints of the sensor and are chosen to meet the overall accuracy requirements.

The next step is to complete the design of the input interface by defining the mounting for the vane and the sensor. Important mounting considerations include:

- Centering of the vane in the gap
- Allowances for end play and run-out (rotary vanes)
- Provisions for initial positioning of the vane relative to the sensor

The output interface must now be designed. The output stage of a vane operated position sensor is identical to that for discrete digital output Hall effect sensing devices. Thus any of the techniques or circuits used for discrete sensors may be applied.

The final steps are:

- Prototype the sensor (breadboard)
- Integrate the vane, sensor and output interface into the system and test the completed sensor

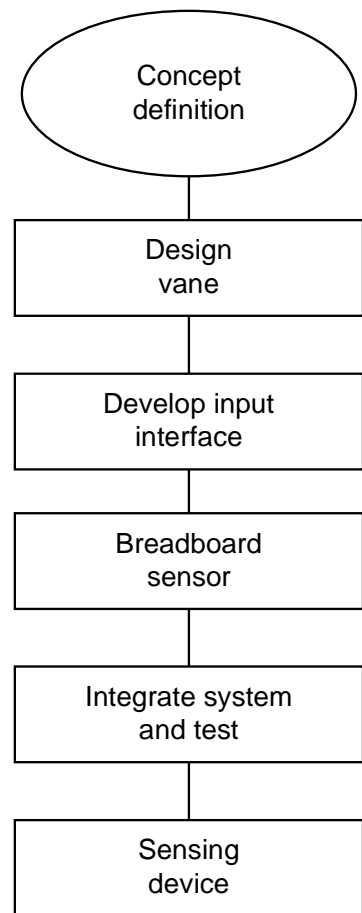

**Figure 6-18 Detailed design - Vane-operated sensor**



### Design approach . . . Digital output current sensor

The digital output current sensor is perhaps the simplest to apply since it is already a complete sensor. Not only has the design of the magnetic system been eliminated, but also the design of the input interface. All that remains is to select the proper current sensor and design the output interface. Chapter 5 should be reviewed for operational characteristics and common output interfaces are discussed in Chapter 4.

An important consideration when applying digital output current sensors is whether AC or DC currents will be detected. As was found in Chapter 5, these sensors are specified in terms of DC current operate and release characteristics. They may, however, be used to detect AC currents as well. When the instantaneous AC current exceeds the operate level, the sensor output will turn ON as for DC current. Since the instantaneous AC current must

fall to zero at the end of the positive half cycle, the sensor output will turn OFF again during that half cycle. Thus the sensor output will be a train of pulses for AC currents with a peak value exceeding the operate current level. An interface circuit which converts these pulses to a constant level signal is shown in Figure 6-19.

The retriggerable one shot (monostable multivibrator) is a digital device which responds with an output pulse when triggered by an input pulse. The output pulse width (time) is independent of the input pulse, depending only on the values of  $R_2$  and  $C$ . The retriggerable feature refers to the property that when another input pulse comes before the end of the output pulse, the output pulse will be extended an additional pulse width without changing state. Thus, if  $R_2$  and  $C$  are chosen to give a pulse width slightly longer than the period ( $1/\text{frequency}$ ) of the AC current, the output will remain constant until the pulses stop. The Q output will give a High (Logic 1) during the pulse train (overcurrent condition) and a Low (Logic 0) otherwise (normal current condition).

Figure 6-19 shows nominal values of  $R_2$  and  $C$  for 60 Hz AC current and a 74123 type retriggerable one shot. Manufacturers' data sheets should be consulted for other frequencies or other types of retriggerable one shots. Chapter 4 should be reviewed for choosing  $R_1$ . Design of the output interface completes the design of the digital output current sensors.

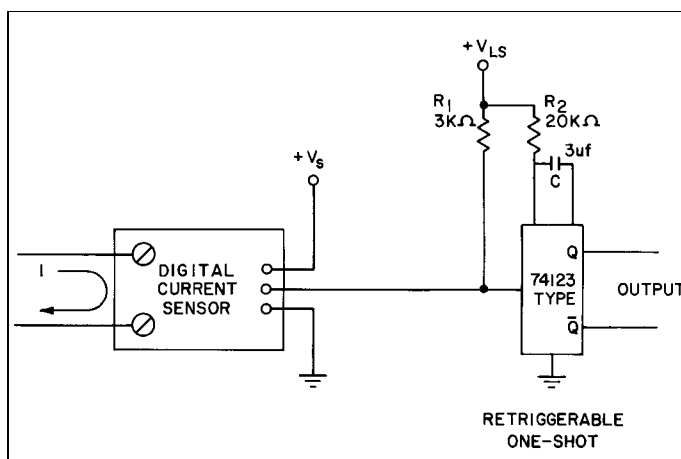

Figure 6-19 AC current sensor with logic level sensor

### Summary

This chapter outlined the steps involved in designing sensors based on a Hall effect sensing device. Many design considerations have been included, but others will depend on a particular application.

# Application Examples

## Introduction

This chapter presents a variety of customer applications as well as a variety of concept illustrations. These applications represent some of the most popular and effective ways of utilizing Hall effect sensing devices. However, the use of these products is far from being limited to these illustrations. In many cases, variations of the concept, may be used in other applications as well.

The following is a partial list of applications/products where MICRO SWITCH Hall effect sensors have been successfully applied.

## Digital output sensor applications

- RPM/speed detectors (motor control)
- Timing measurement (photographic equipment)
- Ignition timing
- Position sensors (as low as .002" detection)
- Pulse counters (printers, motor drives)
- Valve position sensors
- Joy stick applications
- Door interlocks
- Current sensing (motor control systems)
- Fan/damper detection
- Brushless DC motors
- Tachometer pick-up
- Flow meters (replaces reed switches)
- Relays (replaces elect/mech contacts)
- X/Y & indexing tables
- Proximity detectors
- Security (magnetic card or key entry)
- Banking machines (automatic tellers)
- Telecommunications (on/off hook detector)
- Pressure sensors
- Limit switches
- Lens position sensors
- Paper sensors
- Test equipment
- Shaft position sensors
- Vending machines
- Embossing machines

### Linear output sensor applications

- Current sensing
  - Disk drives
  - Variable frequency drives
  - Motor control protection/indicators
  - Power supply protection/sensing
- Position sensing
  - Pressure diaphragms
  - Flow meters
  - Damper controls
  - Brushless DC motors
  - Wiperless/contactless potentiometers
- Encoded switches
  - Rotary encoders
- Voltage regulators
- Ferrous metal detectors (biased Hall)
- Vibration sensors
- Magnetic toner density detection
- Tachometers

### Chapter 7 Application Example directory

Flow rate sensor (digital).....	page 63	Level/tilt measurement sensor.....	page 69
Sequencing sensors.....	page 63	Brushless DC motor sensors.....	page 69
Proximity sensors.....	page 64	RPM sensors.....	page 70
Office machine sensors.....	page 64	Remote conveyor sensing.....	page 70
Adjustable current sensor.....	page 65	Remote reading sensing.....	page 71
Linear feedback sensor.....	page 66	Current sensors.....	page 71
Multiple position sensor.....	page 66	Flow rate sensor (linear output.....	page 72
Microprocessor controlled sensor.....	page 67	Piston detection sensor.....	page 73
Anti-skid sensor.....	page 67	Temperature or pressure sensor.....	page 73
Door interlock and ignition sensor.....	page 67	Magnetic card reader.....	page 74
Transmission mounted speed sensor.....	page 68	Throttle angle sensor.....	page 75
Crankshaft position or speed sensor.....	page 68	Automotive sensors.....	page 76
Distributor mounted ignition sensor.....	page 68		

### Flow rate sensor

Figure 7-1 illustrates a concept that uses a digital output bipolar sensor and magnets mounted to an impeller to measure flow rate for a water softener. In this design, the softener can be made to automatically recharge on demand, instead of on a timed basis. Demand is determined by measuring the amount of water that has passed through the softener. When a certain level is reached, the recharge cycle begins.

There are various methods for designing Hall effect flow meters, but the general principle is the same: each actuation of the sensor, by a magnet or by shunting the magnetic field, corresponds to a measured quantity of water. In the example shown, the magnetic field is produced by magnets mounted on the impeller blade. The impeller blade is turned by the water flow. The sensor produces two outputs per revolution.

Besides the immediate savings derived by the proper usage of the salt, this approach provides more reliability, and longer life and the assurance of a continuing supply of softened water.

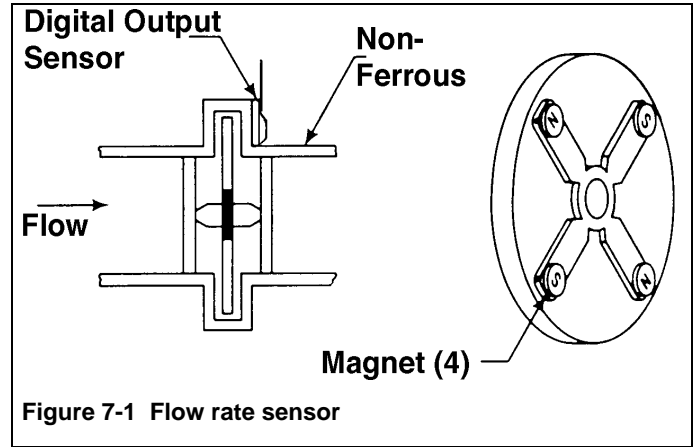

Figure 7-1 Flow rate sensor

### Sequencing Sensors

Sequencing and/or duration of a number of operations can be achieved by different kinds of mechanical configurations, as illustrated by Figure 7-2. In the first example, Figure 7-2A, a number of ferrous disks or cams are clamped to a common shaft. The disks are rotated in the gaps of Hall effect vane sensor. A disk rotating in tandem with its mate is used to create a binary code which can establish a sequence of operations. Programs can be altered by replacing the disks with others having a different cam ratio.

Operation is stated in terms of the position of the disk located in the gap with respect to the center line of the sensor. In the absence of the disk (a cut-out), flux from the magnet reaches the digital output sensor and the output is ON. When the disk material is in the gap, flux is shunted from the transducer and the output changes state.

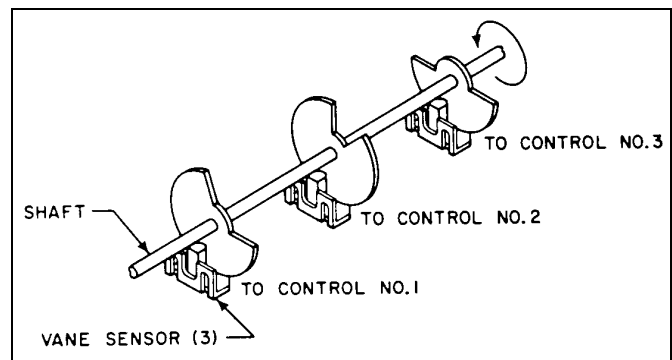

Figure 7-2A Cam-operated vane sensors

Another approach to establishing a series of events is illustrated by Figure 7-2B. Ring magnets are mounted on a rotating shaft. The outputs from the bipolar sensors can be varied by increasing or decreasing the number of pole-pairs on the ring magnets.

There are numerous configurations that could accomplish the sequencing/duration task. The possibilities are endless.

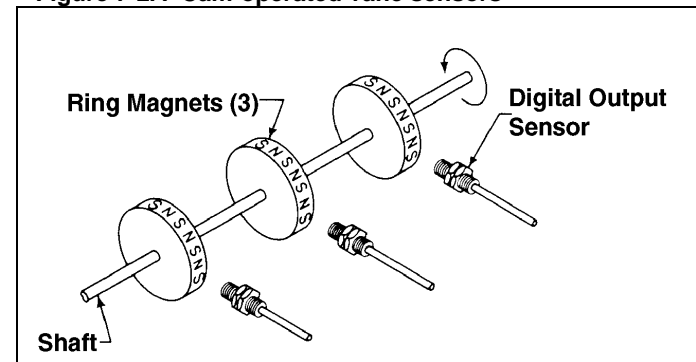

Figure 7-2B Ring magnet operated sensors

**Proximity sensors**

Figure 7-3 illustrates two concepts for developing a proximity sensor that can be used for accurate positioning. In the first example, Figure 7-3A, four digital output unipolar sensors are threaded into an aluminum housing and actuated individually by four magnetic actuators.

In use, event signals are generated by the sensors which represent distances measured from a reference surface. These signals define the acceptable dimensional limits between which the item under test must generate electrical pulses. In a known application, each of the sensors has accumulated at least 8 million operate/release cycles per month and is still operating, without replacement or maintenance.

In the second example, Figure 7-3B, four digital output bipolar sensors are actuated by one magnet mounted on a rod. Applications using this concept can achieve linear positioning accuracy of .002". Sensing various lens locations for photo-processing equipment is an ideal application for this concept. It could also be used to sense the precise location of a moving table for a 35mm slide mounter.

**Office machine sensors**

Office machines are being designed that operate more reliably than ever before. Copiers, fax machines, computer printers - anything in the office with moving parts.

Figure 7-4 illustrates a concept using a mechanically operated Hall effect switch to detect paper flow. Advantages of this approach include: no contacts to become gummy or corroded; very low force operation; extremely long life and direct interface with logic circuitry.

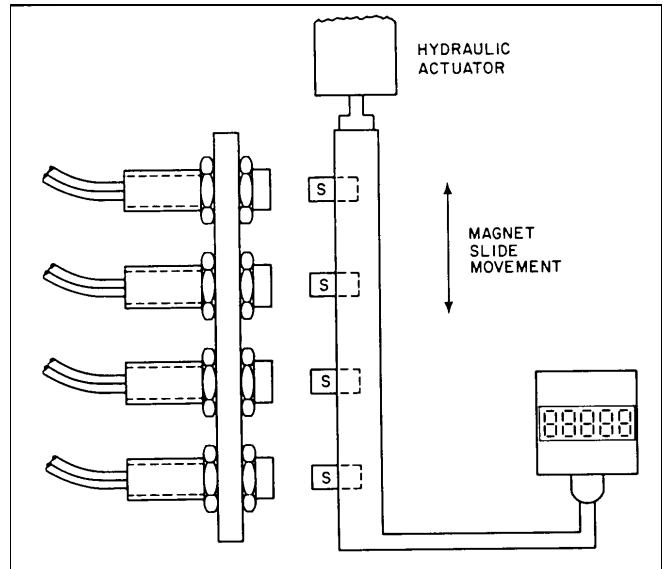

**Figure 7-3A Proximity sensors**

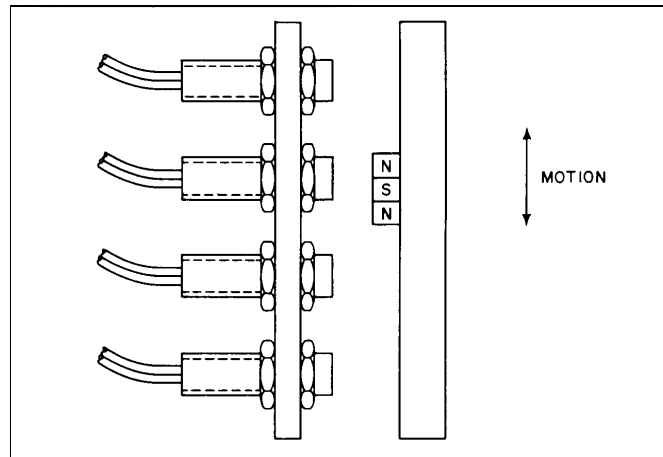

**Figure 7-3B Proximity sensors**

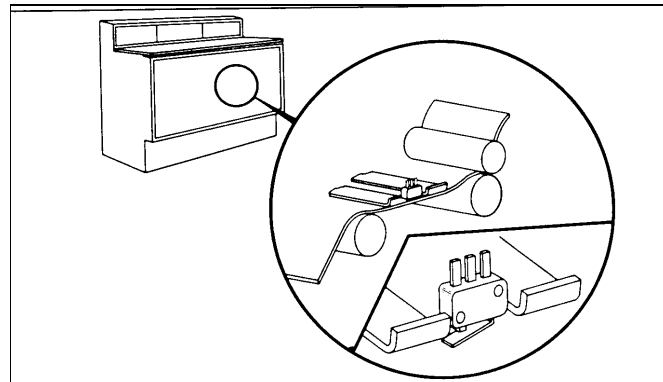

**Figure 7-4 Paper detection sensor**

### Linear output sensor concepts

Linear output Hall effect sensors can provide mechanical and electrical designers with significant position and current sensing capabilities. These sensors combine a Hall effect integrated circuit chip with the state-of-the-art thick film technology. Linear output sensors can be used in a wide variety of sensor applications. Position sensing of cams, shafts, floats and levers, temperature sensing, current sensing, and circuit fault detection are just a few of the many possible applications.

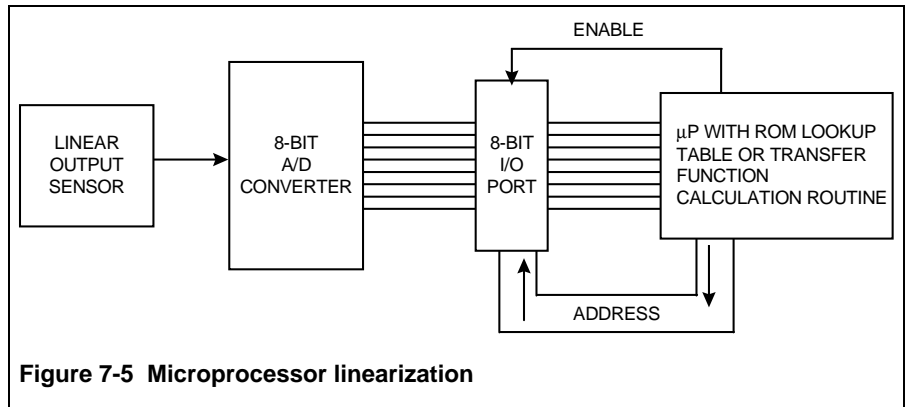

Figure 7-5 Microprocessor linearization

The output voltage of a linear sensor as a function of magnetic field (from a permanent magnet or an electromagnet) is linear, while the output voltage as a function of distance may be quite non-linear. Several methods of converting the voltage output of a linear sensor to one which compensates for the non-linearity of the magnetics as a function of distance are possible. One method of obtaining a linear relationship between distance and gauss is shown in Figure 7-5. This involves converting the analog output to digital form. The digital data is fed to a microprocessor which linearizes the output through a ROM look-up table, or transfer function computation techniques.

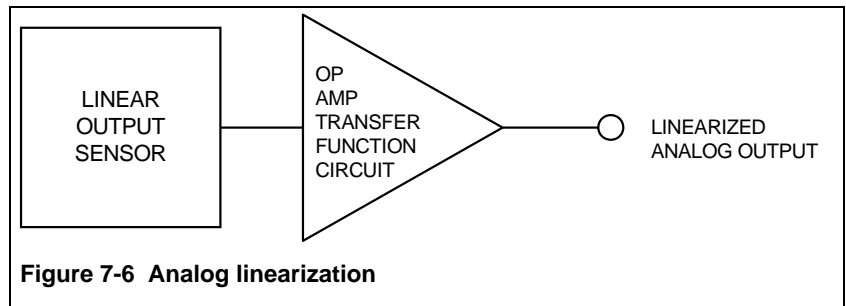

Figure 7-6 Analog linearization

Figure 7-6 diagrams a second method which involves implementing an analog circuit which has the necessary transfer function, to linearize the sensor's output.

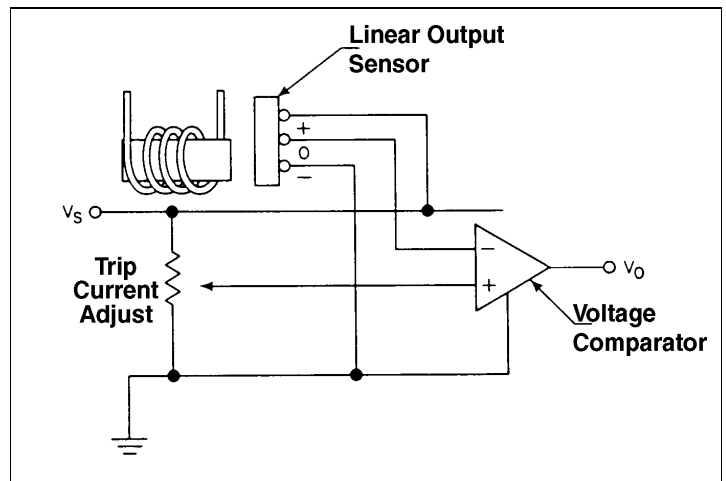

Figure 7-7 Adjustable current sensor

### Adjustable current sensor

Figure 7-7 illustrates a concept approach for an adjustable trip point current sensor used in welding equipment. In this example a toroid core and linear output sensor are combined with a remotely located voltage comparator to produce a precision digital output. The sensor's operate point could be made to vary by less than 20 gauss over the entire temperature range. Thus, a very accurate current sensor with high repeatability over a wide temperature range can be achieved without designing a complex magnetic system.

**Linear feedback sensor**

Linear output sensors have many possible applications where monitoring and linear feedback is needed for analog control systems. A typical application is in a mechanical system where position is controlled by an input voltage, or current sensing in a regulated current power supply. This concept is illustrated in Figure 7-8, where the position of the magnet carrier is automatically adjusted to correspond to the potentiometer setting.

Automated heating, ventilating, and air conditioning (HVAC), and process control are areas where sensors using the principles shown in Figure 7-8 can be used. By mounting a magnet in a valve actuator or damper, exact position can be determined.

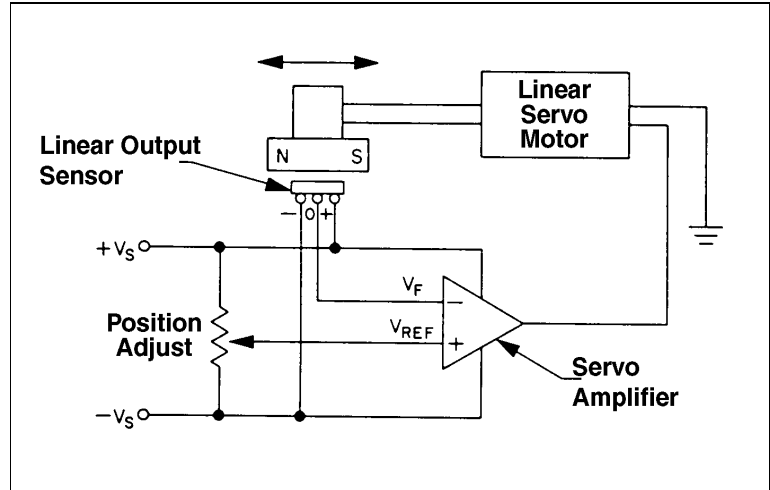

Figure 7-8 Linear feedback sensor for analog control systems

**Multiple position sensor**

Figure 7-9 illustrates how several positions or current levels can be sensed by using several voltage comparators with a linear output sensor. This allows convenient indexing of a mechanical device or current detection of several levels, such as normal current, slight overload, and short circuit. The position sensor shown in Figure 7-9 has three digital outputs, each indicating a different position of the magnet. A sensor of this type could be used in robot control to initiate a move fast, slow down, and stop command.

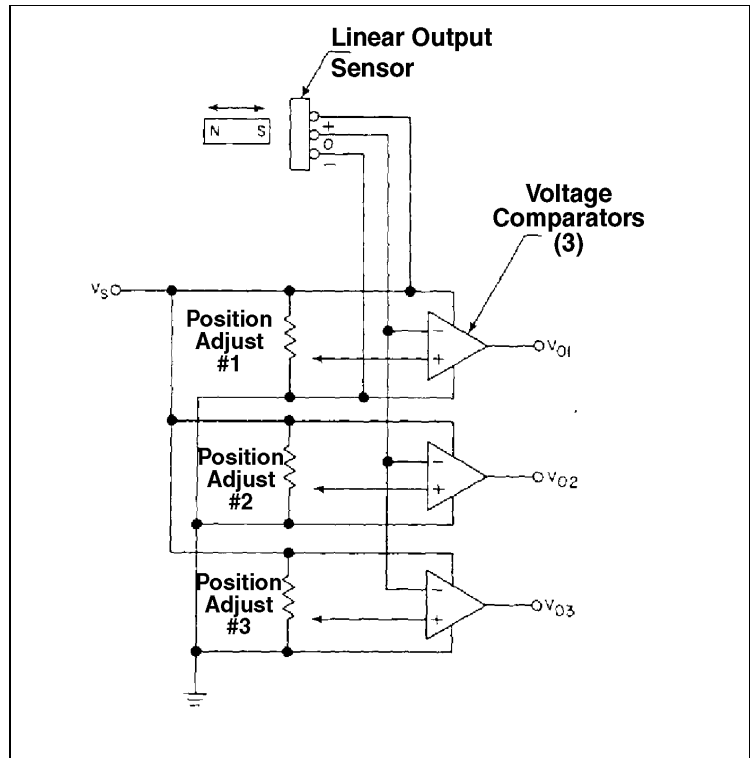

Figure 7-9 Multiple position sensor



### Microprocessor controlled sensor

Figure 7-10 illustrates a concept that combines a digital-to-analog converter and a voltage comparator with a linear output sensor to produce a programmable digital output sensor. A distinct advantage of this approach is that the sensor does not require constant monitoring by the microprocessor. Using data latches in the D/A converter, the microprocessor presets the value where an operation is to take place, then continues with other processing until the sensor/voltage comparator combination signals the microprocessor through the interrupt mode.

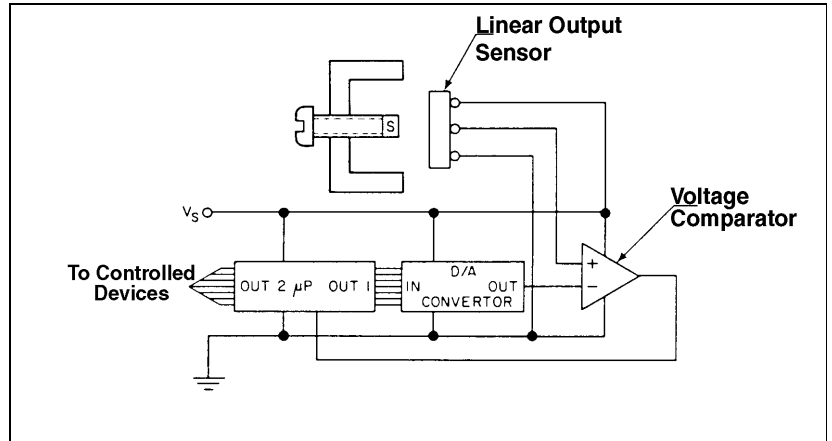

Figure 7-10 Microprocessor controlled sensor

Sensors using this principle can be used in motor current monitoring. The monitor checks for overload, undercurrent, and phase failure, all under microprocessor control. The microprocessor allows programming of desired operate current levels and time delays. This approach allows operation over a wide dynamic range of currents without changing components such as heater elements, shunts, or current transformers.

### Anti-skid sensor

Figure 7-11 shows a possible solution for controlling the braking force of a wheel so that it doesn't lock-up. A biased Hall effect sensor is used. The sensor is positioned to sense an internal tooth gear. The gear could be the disk brake hub.

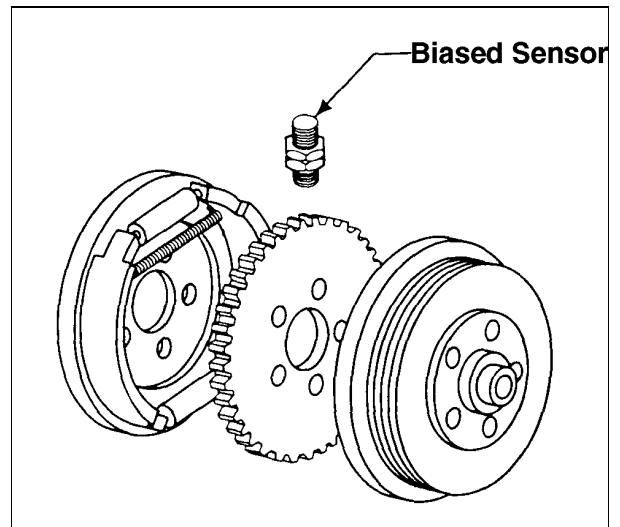

Figure 7-11 Anti-skid sensor

The reaction time of the braking system will determine the frequency of the signal as a function of wheel revolution.

### Door interlock and ignition sensor

Figure 7-12 illustrates a concept approach that uses a digital output bipolar sensor to provide a signal that energizes the inside courtesy lights to provide an extra measure of safety.

A sensor is positioned so that a magnet rotates by it when the key is turned in the door lock. Ice, water and other problems associated with adverse environmental conditions are eliminated. This approach could also serve as an electrical interlock for the ignition system.

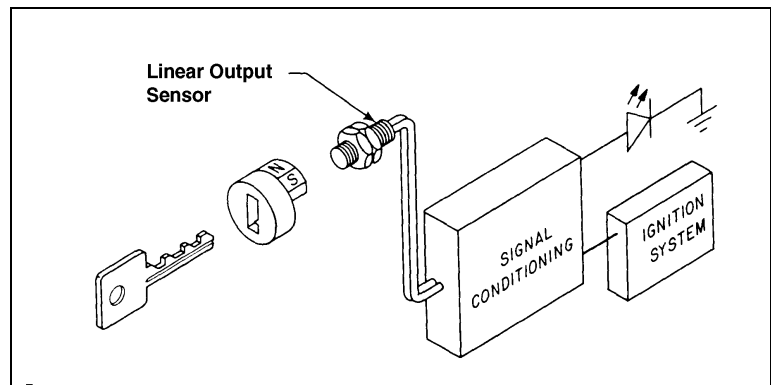

Figure 7-12 Door interlock sensor

### Transmission mounted speed sensor

Figure 7-13 illustrates a simple concept approach for designing a transmission speed sensor. A digital output bipolar sensor is actuated by sensing the magnetic field created by a rotating ring magnet driven by the speedometer output shaft. The frequency of the output signal is proportional to speed. Advantages of this approach are: the output signal is not affected by changes in speed, fast response, long life and high system reliability.

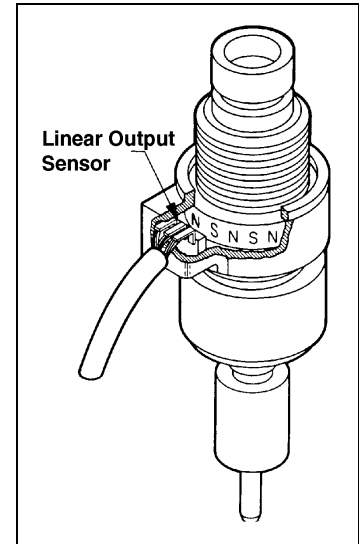

Figure 7-13 Speed sensor

### Crankshaft position or speed sensor

A temperature compensated  $-40^{\circ}\text{C}$  to  $+150^{\circ}\text{C}$  ( $-40^{\circ}\text{F}$  to  $302^{\circ}\text{F}$ ) vane operated sensor is mounted in the damper hub lip, as illustrated in Figure 7-14. The frequency of the output signal will be proportional to the speed of the crankshaft, even down to zero speed. Since the magnetic field is being interrupted, vibration, eccentricity and end play tolerance have little effect on the output signal. Notches in the lip can be used as timing marks to indicate the position of the crankshaft. Direct interfacing of the sensor to the on-board microprocessor adds additional reliability to the system.

### Distributor mounted ignition sensor

Figure 7-15 illustrated how the points in the distributor can be replaced by a vane operated sensor. A cup-shaped vane, with as many teeth as there are engine cylinders passes through a digital output vane sensor. The resultant logic level pulses trigger ignition system firing without the use of points. The major advantages of this approach are low speed operation (output signal not affected by changes in speed), fast response, simplified system design and high system reliability. Automotive ignition systems are one of the toughest applications with a temperature range of  $-40^{\circ}\text{C}$  to  $150^{\circ}\text{C}$  and 4.5 to 24 VDC voltage range.

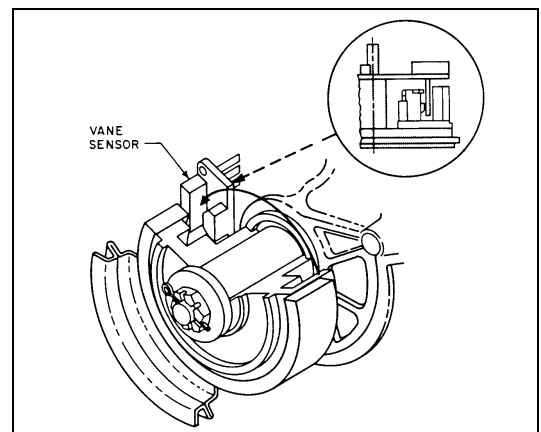

Figure 7-14 Speed sensor

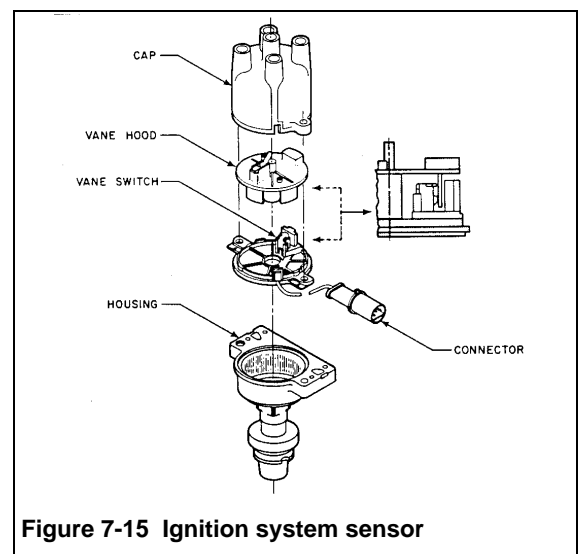

Figure 7-15 Ignition system sensor

### Level/tilt measurement sensor

A digital output unipolar sensor can be installed in the base of a machine with a magnet mounted in a pendulum fashion as illustrated in Figure 7-16. As long as the magnet remains directly over the sensor, the machine is level. A change in state of the output as the magnet swings away from the sensor is indication that the machine is not level. A linear output sensor/magnet combination could also be installed in such a manner as to indicate degree of tilt.

### Brushless DC motor sensors

Brushless DC motors differ from conventional DC motors in that they employ electronic (rather than mechanical) commutation of the windings. Figure 7-17 illustrates how this electronic commutation can be performed by three digital output bipolar sensors. Permanent magnet materials mounted on the rotor shaft operate the sensors. The sensors sense the angular position of the shaft and feed this information to a logic circuit. The logic circuit encodes this information and controls switches in a drive circuit. Appropriate windings, as determined by the rotor position, are magnetic field generated by the windings rotates in relation to the shaft position. This reacts with the field of the rotor's permanent magnets and develops the required torque.

Since no slip rings or brushes are used for commutation; friction, power loss through carbon build-up and electrical noise are eliminated. Also, electronic commutation offers greater flexibility, with respect to direct interface with digital commands.

The long maintenance-free life offered by brushless motors makes them suitable for applications such as; portable medical equipment (kidney dialysis pumps, blood processing equipment, heart pumps), ventilation blowers for aircraft and marine submersible applications.

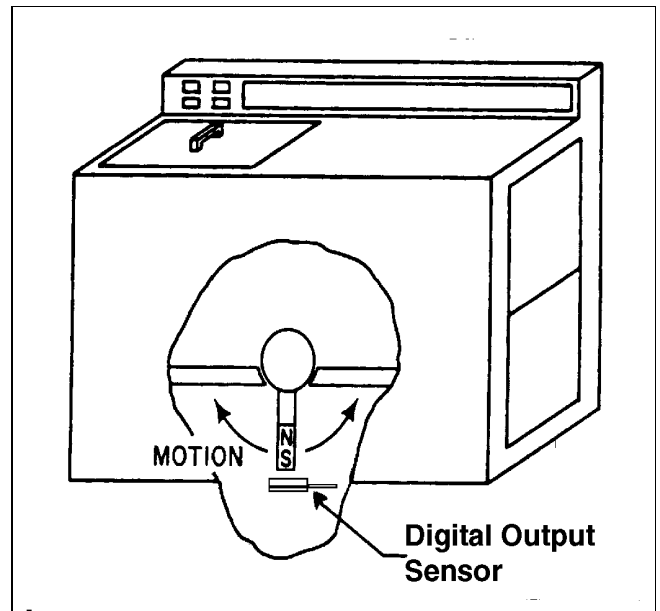

Figure 7-16 Level/tilt sensor

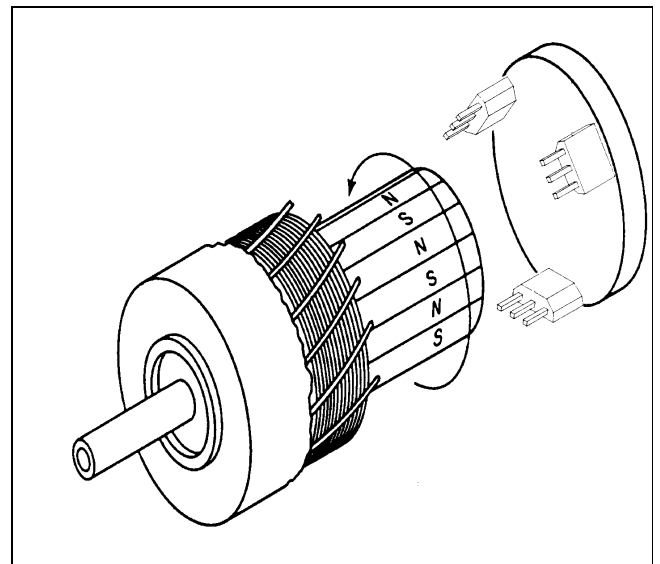

Figure 7-17 Brushless DC motor sensors

### RPM sensors

The RPM sensor is one of the most common applications for a Hall effect sensor. The magnetic flux required to operate the sensor may be furnished by individual magnets mounted on the shaft or hub or by a ring magnet. Figure 7-18 illustrates some basic concepts for designing RPM sensors.

Most of the RPM sensor functions listed below can be accomplished using either a digital or linear output sensor. The choice depends on the application's output requirements.

- Speed control
- Control of motor timing
- Zero speed detection
- Tape rotation
- Under or overspeed detection
- Disk speed detection
- Automobile or tractor transmission controller
- Fan movement
- Shaft rotation counter
- Bottle counting
- Radical position indication
- Drilling machines
- Linear or rotary positioning
- Camera shutter position
- Rotary position sensing
- Flow-rate meter
- Tachometer pick-ups

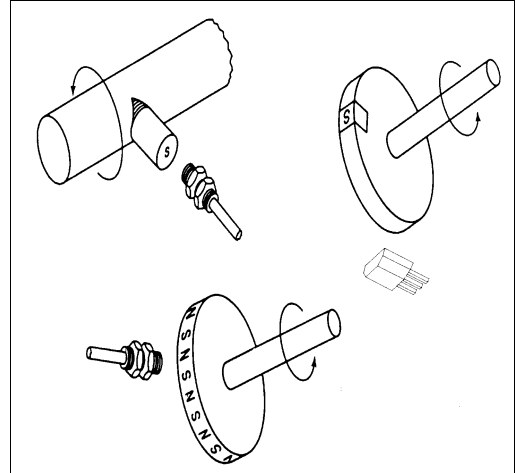

Figure 7-18 Basic RPM sensors

### Remote conveyor sensing

Figure 7-19 illustrates a simple solution for keeping tabs on a remote conveyor operation. A digital output unipolar sensor is mounted to the frame of the conveyor. A magnet mounted on the tail pulley revolves past the sensor to produce one output per revolution. This output can be used to provide an intermittent visual or audible signal at a remote location to assure that all is well. Any shutdown of the conveyor will interfere with the normal signal and alert operators of trouble. With no physical contact, levers or linkages, the sensor can be installed and forgotten.

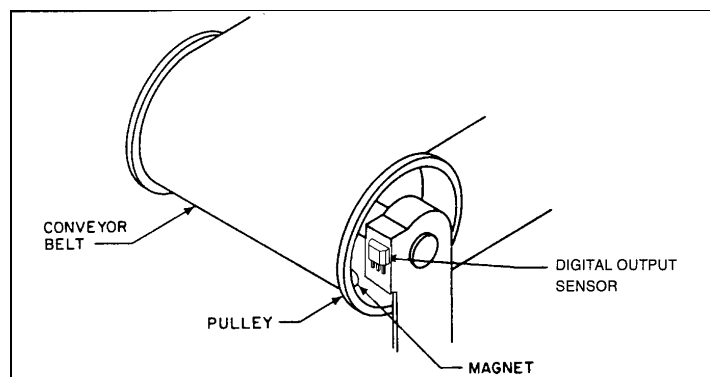

Figure 7-19 Remote conveyor sensing

### Remote reading sensor

A digital output bipolar sensor actuated by a rotating ring magnet or interrupting the flux field in a vane sensor can initiate almost any action. Figure 7-20 illustrates two concept approaches for a remote reading sensor.

Self service gas stations have created a demand for pumps with remote reading capabilities. Every ON/OFF operation of the sensor could correspond to .1 gallon. Another approach could use a vane switch interrupted by an impeller blade. Once again each operation of the sensor could correspond to a measured amount.

The mechanical mechanism in a utility meter can be replaced with a ring magnet and bipolar sensor to provide a pulse output. These pulses are counted electronically to determine power usage. The reading is stored in a transponder and data fed to a master computer by telephone lines. Working through the telephone company, this system can extract meter readings, analyze usage and control high-energy-using appliances (such as air conditioners) by shutting them off during peak usage periods.

The small size, exceptional long life, logic compatibility and non-contacting operation of the sensor are ideal for applications of this type.

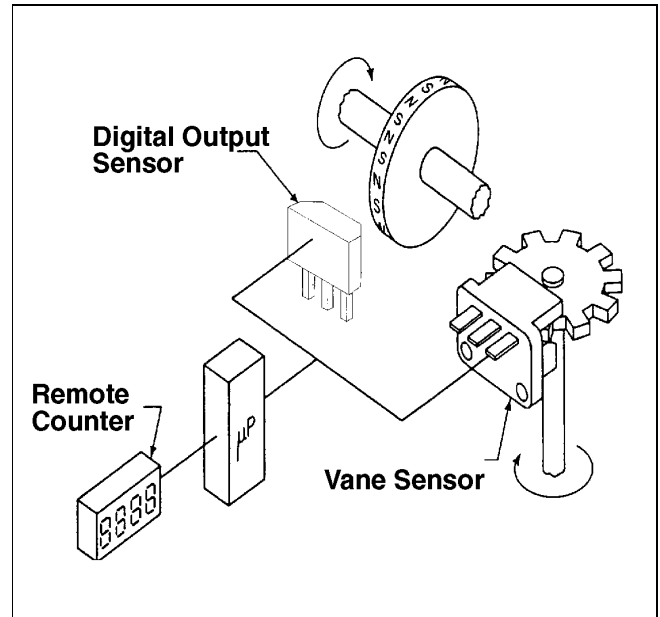

Figure 7-20 Remote reading sensor

### Current sensors

Linear output Hall effect sensors can be used to sense currents ranging from 250 milliamperes to thousands of amperes. The isolated (no passive connection required) analog voltage produced by the sensor can be modified by adding amplifiers or comparators to achieve digital outputs, level shifting, temperature compensation, gain changes or other desired parameters. Linear sensors offer both high frequency response (AC) and DC measurements. When a linear sensor is positioned near a current carrying conductor, the output voltage developed is proportional to the magnitude of the field surrounding the conductor. Since the field magnitude at a particular point is proportional to the current level.

The simplest current sensor configuration consists of a linear output sensor mounted near a conductor as illustrated in Figure 7-21. This type of configuration is usually used to measure relatively large current surges around high voltage lines or equipment found in electrical power plants.

The sensitivity of the simple current sensing system shown in Figure 7-21 can be increased by adding a flux concentrator (refer to chapter 3) to the sensor. With the addition of a flux concentrator, these sensors can be used to check over or under speed, overload (current surges), undercurrent and phase failure for large motors or generators.

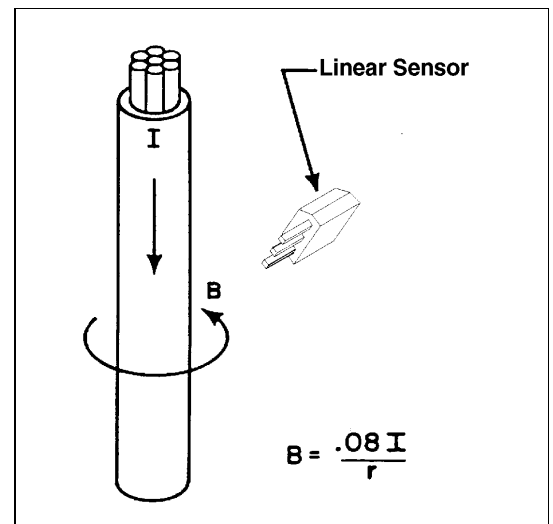

Figure 7-21 Simple current sensor

Figure 7-22 illustrates an even more sensitive current sensor system. This approach consists of a toroid core with a linear sensor positioned in the gap. The core encloses the sensor and acts as an additional flux concentrator. These sensors are able to measure currents from 250 milliamperes to approximately 1000 amperes.

Selecting the core material for the toroid requires some care. For example, cold rolled steel has high remanence. The magnetic induction remains after removal of the applied magnetomotive force, therefore, this would be a poor choice. Ferrite materials, silicon steels, or permally are logical choices because of high permeability and low remanence. Your final choice must be based on actual testing in the application. Values of residual induction given by the materials suppliers are usually for a closed magnetic loop. Current sensors requires large air gaps, therefore, application characteristics should be measured. The residual induction values given by suppliers do, however, provide relative indications for material comparison.

Coil position on the toroid core is not critical. The wire used should be capable of carrying the maximum current continuously. The maximum wire gage provides minimum voltage drop. Count the number of turns as the number in the center of the core.

Current sensors using toroids are useful in systems which require a broad dynamic range, no series resistance and a linear measure of current. An additional benefit is that the sensor can provide isolation from two dissimilar power supplies as might be found in such applications as motor controls with current feedback.

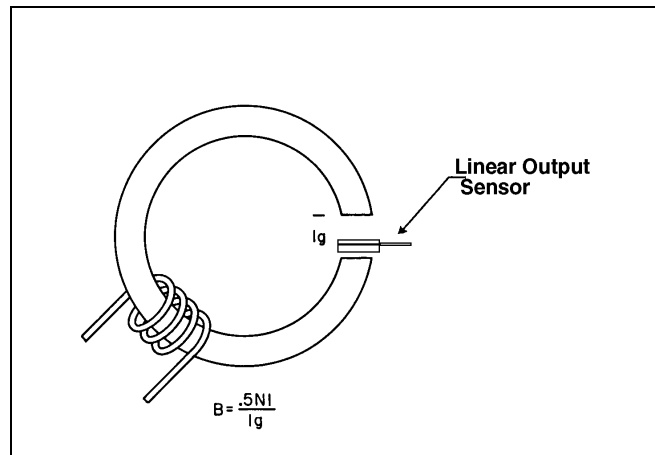

Figure 7-22 Low level current sensor

### Flow rate sensor

Figure 7-23 illustrates a concept design for a flow meter using a biased linear output sensor. As the flow rate through the chamber increases, a spring loaded paddle turns a threaded shaft. As the shaft turns, it raises a magnetic assembly that actuates the sensor. When flow rate decreases, the coil spring causes the assembly to lower thus reducing the output voltage of the sensor.

The magnetics and screw assembly are designed to provide a linear relationship between the measured quantity, flow rate, and the output voltage of the sensor.

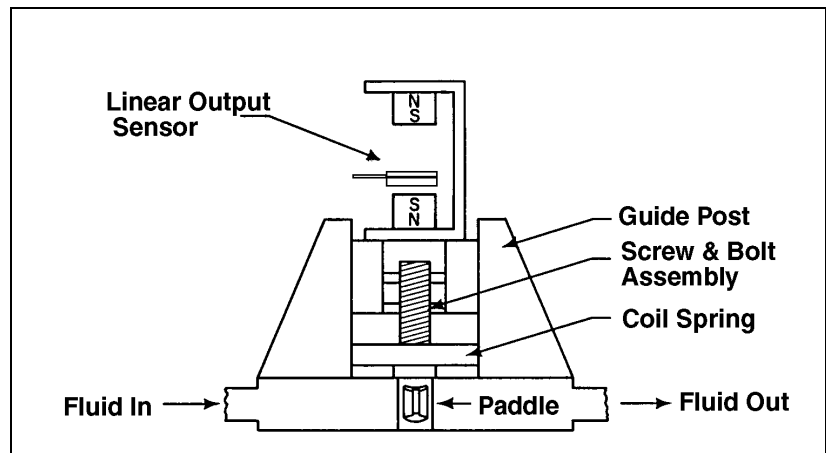

Figure 7-23 Flow rate sensor

If only critical flow is important, the magnetics can be modified to use the bipolar slide-by mode. Using bipolar slide-by, a high resolution measure of flow rate can be achieved at a critical level.

### Piston detection sensor

Figure 7-24 illustrates two possible solutions for detecting position of the piston in a high-pressure non-ferrous cylinder. In the first example, Figure 7-24A, plastic form ring magnets are implanted in the grooves of the piston. Three linear output sensors are mounted on the outside of the cylinder to detect top and bottom stroke and indicate mid position for the analog control system. An advantage of this approach is; since the magnets need no external power, they can be sealed inside the cylinder.

In the second approach, Figure 7-24B, the piston is made of ferrous material (cylinder non-ferrous). Once again three linear output sensors are mounted on the outside of the cylinder. In this case bias magnets are used to “fine tune” the characteristics of the magnetic system. In operation, whenever the ferrous piston passes by the sensing face of the sensor, it acts like a flux concentrator to increase the field detected.

Advantages of both approaches include; small size of sensors, no external power for the magnets, temperature range of -40°C to +150°C (-40°F to +302°F) and the ability to operate in contaminated environments.

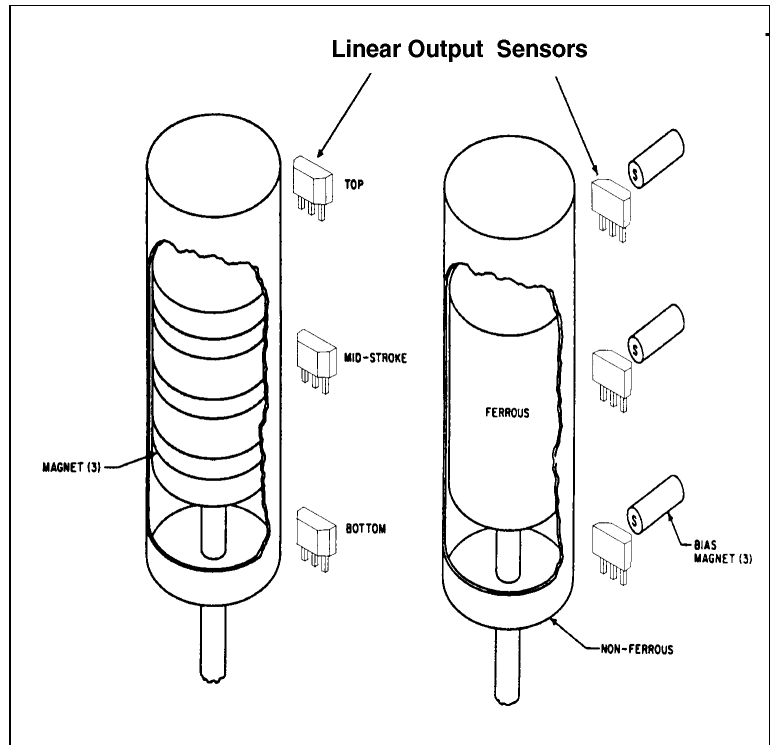

Figure 7-24 Piston detector sensors

### Temperature or pressure sensor

The properties of a linear output sensor allow quantities other than position and current to be sensed. When a linear sensor is combined with appropriate magnetics, it can be used to measure temperature or pressure. Figure 7-25 illustrates this concept.

In pressure sensing, a magnetic assembly is attached to a bellows assembly. As the bellows expands and contracts, the magnetic assembly is moved. If the sensor is placed in close proximity to the assembly, an output voltage proportional to pressure input can be achieved.

Temperature measurement works similarly to pressure, except that a gas with a known thermal expansion characteristic is sealed inside the bellows assembly. As the chamber is heated, the gas expands causing a voltage from the sensor that is proportional to the temperature.

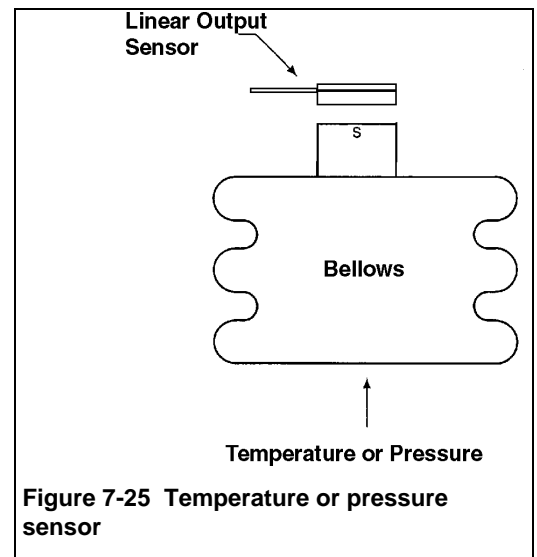

Figure 7-25 Temperature or pressure sensor

### Magnetic card reader

A door interlock security system can be designed using a linear output sensor, magnetic card and a microprocessor linearization circuit as illustrated in Figure 7-26. In this example the card slides-by the sensor producing an output. This analog signal is converted to digital, to provide a crisp signal to operate the relay. When the relay's solenoid pulls-in, the door can be opened.

For systems that require additional security measures, a series of magnet can be molded into the card. A constant speed motor-driven tray slides this multi-coded card past the sensor or an array of linear output sensors, generating a series of pulses. These pulses are addressed to a decoding unit that outputs a signal when the correct frequency is present. Or it could generate a multi bit encoded function, that allows entry to selected units.

Computer systems and banking terminals are ideal applications for this concept.

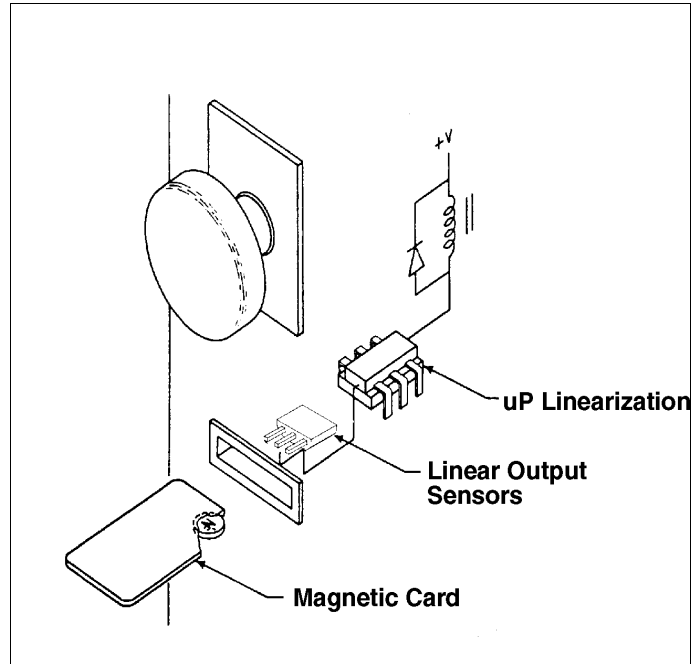

Figure 7-26 Magnetic card reader



### Throttle angle sensor

Figure 7-27 illustrates a concept that uses a linear output sensor to provide a signal proportional to the angular position of the throttle butterfly valve. The arm of the throttle is contoured to provide the desired non-linear characteristics. The magnet is mounted on the choke lever.

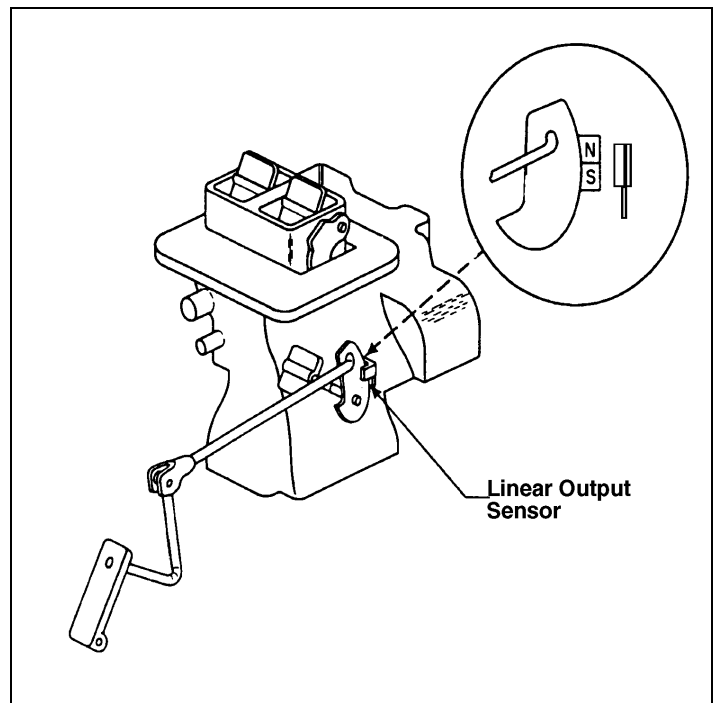

Figure 7-27 Throttle angle sensor

### Automotive sensors

Figure 7-29 suggests many concepts where Hall effect sensors can be applied as monitoring, positioning or safety feedback devices for the automotive market. Both digital and linear output sensors are used in such applications as: flow meters, current sensors, position sensors, interlocks, pressure sensors, RPM sensors, etc.

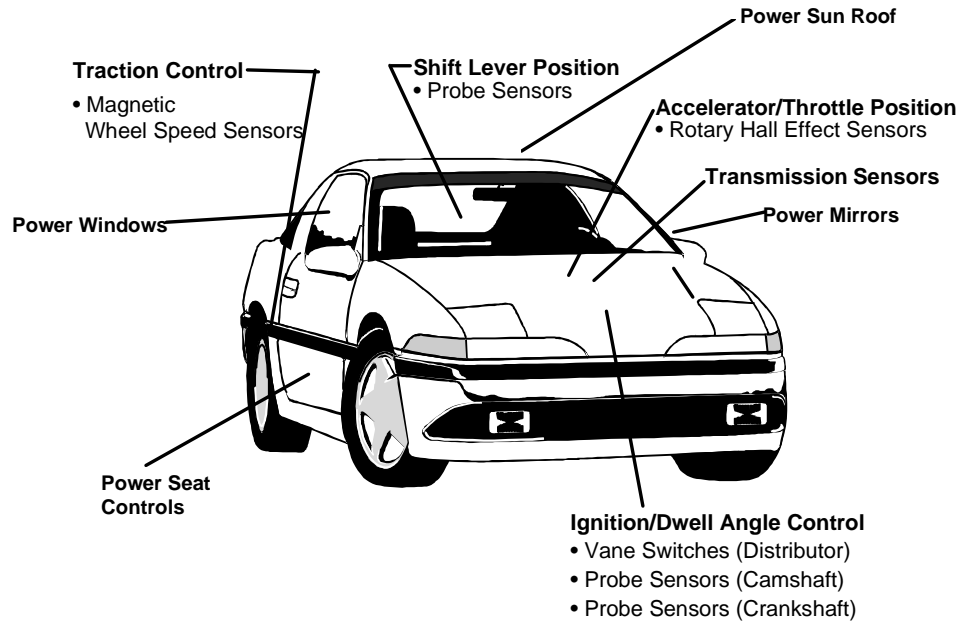

Figure 7-29 Automotive sensor concepts

# Appendix A

# Units and Conversion Factors

## Units for Magnetic Quantities

Quantity	Symbol	Unit, CGS	Unit, SI	(SI)/(CGS)Ratio*
Length	L	centimeter, cm	meter, m	$10^2$
Mass	M	gram, g	kilogram, kg	$10^3$
Time	t	second, s	second, s	1
Magnetic Flux	$\Phi$	maxwell	weber, Wb	$10^8$
Flux Density	B	gauss, G	tesla, T	$10^4$
Magnetic Field Strength	H	oersted, Oe	ampere/meter, A/m	$4\pi/10^3$
Magnetomotive Force	F	gilbert, Gb	ampere, A	$4\pi/10$
Permeability of a Vacuum	$\mu^\circ$	(unity)	henry/meter, h/m	$10^7/4\pi$
Reluctance	$\mathfrak{R}$	gilbert/maxwell	1/henry, H <sup>-1</sup>	$4\pi/10^9$
Permeance	P	maxwell/gilbert	henry, H	$10^9/4\pi$

\*A quantity in SI units must be multiplied by this ratio to convert to CGS units.

Units for Electrical Quantities

Quantity	Symbol	Unit, SI	
		Name	Abbr.
Current	I or i *	ampere	A or a
Charge	Q or q *	coulomb	C
Voltage (electromotive force, potential difference)	V or v * emf, E or e PD	volt	V or v
Power	P	watt	W or w
Resistance	R **	ohm	$\Omega$
Reactance	X **	ohm	$\Omega$
Impedance	Z **	ohm	$\Omega$
Conductance	G **	mho	
Admittance	Y **	mho	
Susceptance	B **	mho	
Capacitance	C	farad	F or f
Inductance	L	henry	H or h
Frequency	F or f	Hertz	Hz
Period	T	seconds	s

\* Capital letter generally used for peak RMS or DC value; small letter used for instantaneous values.

\*\* Small letter generally used for the internal value of a component

Multiples and submultiples of units (prefixes)

Multiples
$10^{12}$ = tera = T
$10^9$ = giga = G
$10^6$ = mega = M
$10^3$ = kilo = k
$10^2$ = hecto = h
10 = deca = da

Submultiples
$10^{-1}$ = deci = d
$10^{-2}$ = centi = c
$10^{-3}$ = milli = m
$10^{-6}$ = micro = $\mu$
$10^{-9}$ = nano = n
$10^{-12}$ = pico = p
$10^{-15}$ = femto = f
$10^{-18}$ = atto = a

# Magnet Application Data

## Nature of Magnetism

Magnetism is considered by some to be a mysterious phenomenon. This is not true, except insofar as the ultimate nature of gravity, electrostatic fields, matter, and radiation are also mysterious. All of these can, in fact, be described by means of mathematical expressions that predict their behavior and in this sense, are well understood.

In order to understand the magnetic behavior of materials, it is necessary to take a microscopic view of matter. A suitable starting point is the composition of the atom, which Bohr described as consisting of a heavy nucleus and a number of electrons moving around the nucleus in specific orbits (Figure B-1).

Closer investigation reveals that the atom of any substance experiences a torque when placed in a magnetic field; this is called a magnetic moment. The resultant magnetic moment of an atom depends upon three factors - the positive charge of the nucleus spinning on its axis, the negative charge of the electron spinning on its axis, and the effect of the electrons moving in their orbits. The magnetic moment of the spin and orbital motion of the electron far exceed that of the spinning nucleus. However, this magnetic moment can be affected by the presence of an adjacent atom. For simplicity, we chose the hydrogen atom. Accordingly, if two hydrogen atoms are combined to form a hydrogen molecule, it is found that the electron spins, the nucleus (proton) spins, and the orbital motions of the electrons of each atom oppose each other so that a resultant magnetic moment of zero should be expected. Although this is almost the case, experiment reveals that when a hydrogen molecule is exposed to a magnetizing force, there is a slight decrease in magnetic field as compared with free space. Materials in which this behavior manifests itself are called diamagnetic. Besides hydrogen, other materials possessing this characteristic include silver and copper.

Continuing further with the hydrogen molecule, assume it is made to lose an electron, thus yielding the hydrogen ion. Complete neutralization of the spin and orbital electron motions no longer takes place. In fact, when a magnetic field is applied, the ion is so oriented that its net magnetic moment aligns itself with the field, thereby causing a slight increase in flux density. This behavior is described as paramagnetism and is the characteristic of such materials as aluminum and platinum.

So far, we have considered those elements whose magnetic properties differ only vary slightly from those of free space. As a matter of fact, the vast majority of materials fall within this category. However, there is one class of materials – principally iron, nickel, cobalt and many other alloys – for which the relative permeability is very many times greater than that of free space. These materials are called ferromagnetic and are of great importance in magnetic applications. The reason iron (and its alloys) is much more magnetic than other elements can be answered by the Domain theory of magnetism proposed by Weiss. Like all metals, iron is crystalline in structure with the atoms arranged in a space lattice. Domains are subcrystalline particles of varying sizes and shapes containing about  $10^5$  atoms in a volume of approximately  $10^{-9}$  cubic centimeters. The distinguishing feature of the domain is that the magnetic moments of its constituent atoms are all aligned in the same direction. Thus in a ferromagnetic material, not only must there exist a magnetic moment due to a

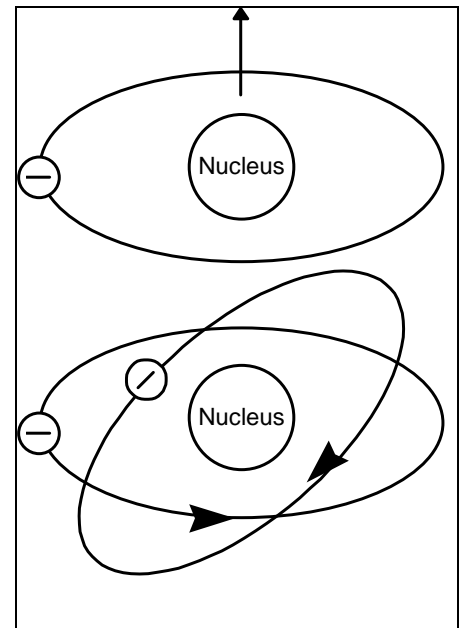

Figure B-1 Bohr's model of the atom

non-neutralized spin of an electron in inner orbit, but also the resultant spin of all neighboring atoms in the domain must be parallel.

Domains act independently of each other, and for a specimen of unmagnetized iron these domains are aligned randomly so that the net magnetic moment is zero. Application of an external field of sufficient magnitude will cause the magnetic moments of all the domains to align themselves parallel to the external applied field. When this state is reached the iron is said to be saturated – there is no further increase in flux density over that of free space for further increases in magnetizing force.

In the case of pure iron, if the external field is reduced to zero, it will be found that the magnetic moments will return to the randomly ordered condition (if a slight demagnetizing force is present). Materials with this property are referred to as magnetically soft and used in electromagnets. In the case of the permanent magnet materials, it is found that the magnetic moments will strongly resist being realigned in a random fashion. These materials are referred to as being magnetically hard.

### Locked-in Domains

It is a common fallacy that a permanent magnet supports a magnetic field external to itself by means of the expenditure of some internal energy, that it is similar to a battery having a limited period of diminishing usefulness, or in the extreme case, similar to an electronic light bulb, whose usefulness comes to a definite and abrupt ending. Such is not the case.

The ability of a permanent magnet to support an external magnetic field results from locked-in positions of small magnetic domains within the magnet itself. These locked-in positions, once established by initial magnetization, are held until acted upon by forces exceeding these locked-in forces. The energy involved in the repeated performance of various functions generally associated with the permanent magnet comes not from within the magnet, but from external sources; the magnet merely acting as an intermediary or transducer in converting this external energy to some other useful form. For example, when magnets are used in a generator, the driving motor furnishes the initial mechanical energy. The resulting electrical energy does not come from the magnet.

Magnetized permanent magnets differ from batteries and radioactive materials since they are potential energy sources and consequently do not run down. Thus, the magnetic field surrounding the magnet does not require energy to maintain it and there is no theoretical reason for a permanent magnet to continually lose strength.

### Material Characteristics

The original magnets were lodestones, an iron oxide magnetized by lightning. Lodestones were used as early as 2700 BC by the Chinese for compasses. Until 1600 when Gilbert did the first theoretical study of magnetism, lodestones were considered to be magic. Gilbert developed methods of making magnets from iron and established that the earth itself was a magnet.

In the latter part of the 19<sup>th</sup> Century, the first materials developed specifically for permanent magnets came into use. Early magnet materials, chrome, cobalt, and tungsten steels were relatively unstable metallurgically and magnetically. In 1932, the Japanese announced that excellent properties were obtained from an aluminum-nickel-iron alloy. This material became subject to intensive investigation. The ultimate result of these investigations was the development of an aluminum-nickel-cobalt alloy (Alnico) which had high metallurgical and magnetic stability.

### Alnico

Alnico magnets are made by pressing metal powders into approximately the desired shape and then sintering at elevated temperatures. Small grain structures result, providing magnet materials with more uniform flux distribution and superior mechanical properties. Alnico is well-suited to the mass production of small magnets with intricate shapes.

## Indox ®

Indox magnets are chemically inert with the composition MO-Fe<sub>2</sub>O<sub>3</sub> (M representing barium, strontium, lead or a combination thereof). They are formed by compaction and sintering, are hard and brittle but can be ground, usually with diamond wheels, to obtain closer tolerances than those maintained in the as-pressed condition.

Indox magnets are poor conductors of heat and electricity. Shock, stress and vibration will not affect their magnetic characteristics. An Indox magnet will be physically destroyed before any change in characteristics is noted. Figure B-2 summarizes Indox properties.

Figure B-2 Typical Indox Properties

Indox	B <sub>r</sub> (Kilogauss)	H <sub>c</sub> (Oersted)	(B <sub>d</sub> H <sub>d</sub> ) <sub>MAX</sub> (Mega-Gauss-Oersted)
1	2.2	1825	1.0
2	2.9	2450	1.8
3	3.35	2350	2.6
4	2.55	2300	1.5
4-HR	2.85	2600	1.9
5	3.8	2525	3.4
6	3.3	2800	2.45
7	3.45	3250	2.8
8	3.85	3050	3.5

## Lodex ®

Lodex is a family of single domain, fine particle magnet materials that can be pressed or extruded to form a finished magnet. Domain-sized particles and binder are mixed in powder form and then pressed to final shape. Lodex lends itself to small and intrically-shaped permanent magnets. The magnetic properties of Lodex are summarized in Figure B-3.

Figure B-3 Typical Lodex Properties

Lodex	B <sub>r</sub> (Kilogauss)	H <sub>c</sub> (Oersted)	(B <sub>d</sub> H <sub>d</sub> ) <sub>MAX</sub> (Mega-Gauss-Oersted)
30	4.0	1250	1.68
31	6.25	1140	3.4
32	7.3	940	3.4
33	8.0	860	3.2
36	3.4	1220	1.45
37	5.5	1000	2.1
38	6.2	840	2.2

## Rare Earth

Rare Earth magnets are composed of elements including Erbium, Gadolinium, Terbium, Dysprosium, Holmium and Samarium in combination with Cobalt.

These magnets are fabricated by pressing small particles of rare earth cobalt powder properly aligned (by the influence of a magnetic field), then sintering to high densities and heat treating to optimize properties. Rare earth magnets feature very high peak energy products, but their relatively high costs generally limit them to applications where small size, high magnetic strength and/or high resistance to demagnetizing fields are important. The magnetic properties of rare earth magnets are summarized in Figure B-4.

Figure B-4 Typical Rare Earth Properties

Rare Earth	$B_r$ (Kilogauss)	$H_c$ (Oersted)	$(B_r H_d)_{MAX}$ (Mega-Gauss-Oersted)
Hicorex 90A	8200	7500	16.0
Hicorex 90B	7500	8200	18.0
Hicorex 92	6000	5500	9.0
Hicorex 93	7000	6000	12.0
Hicorex 96A	10250	9500	26.0
Hicorex 99C	10600	6000	27.0
Incor 16	8100	7900	16.0

### Factors influencing permanent magnet strength

Permanent magnets are truly permanent – they do not wear out. However, various factors, such as time, temperature and external fields, can produce changes in the strength of a permanent magnet. These factors should be considered when selecting a magnetic material.

#### Time

In the older permanent magnet materials, such as cobalt-steel, some metallurgical changes take place as a function of time. If such a magnet is magnetized before these changes have stabilized, flux changes will occur. (This effect can be reduced to a negligible factor by artificial aging.) In the magnet materials such as Alnico or Ceramic, metallurgical changes do not take place in any measurable degree at room temperature.

A freshly magnetized permanent magnet will lose a minor percentage of its flux, as a function of time. This loss of flux can be essentially eliminated by a partial demagnetization of the charged magnet in the amount of 7% to 15%. This is most conveniently accomplished by an AC field. The AC field should be in the same direction as the magnetizing field. It should be reduced to zero gradually, either by withdrawing the magnet with power on, or by reducing the AC voltage to zero with a variable auto-transformer.

#### Temperature

Temperature effects fall into three categories: Metallurgical, Irreversible and Reversible.

**Metallurgical** changes may be caused by exposure to too high a temperature. Such flux changes are not recoverable by remagnetization. The approximate maximum temperatures which can be used without experiencing metallurgical changes range from 100°C for Lodex to 1080°C for the ceramics. Figure B-5 shows the maximum temperature for typical magnet materials. The effect of metallurgical changes, if present, can be avoided only by long-term exposure of the magnet to the temperature involved, prior to magnetizing.

Figure B-5 Maximum temperature without metallurgical changes

Material	Temperature (°C)	Curie Temperature ( $\pm 10^\circ\text{C}$ )
Lodex	100	780
Hicorex	250	700
Incor	250	700
Barium Ferrite	400	450

**Irreversible** losses are defined as partial demagnetization of the magnet, caused by exposure to high or low temperatures. Such losses are recoverable by remagnetization, and are reduced or eliminated by magnet stabilization.



The ideal method for stabilizing magnets against temperature-induced irreversible losses, is installing them in the magnetic circuit (or assembly) for which they are intended, magnetize, then subject the assemblies to several temperature cycles which they are expected to experience in service.

The magnetized assembly may be partially demagnetized by means of an AC field, following the procedure described in **Time**. A rule of thumb to follow is determining by experiment that temperature cycling will cause X% flux loss, then the AC field should be such as to cause a 2X% flux loss, to properly stabilize against temperature.

**Reversible** changes in flux can occur with temperature. For example, if any ceramic grades are heated 1°C above ambient temperature, they will lose 0.19% flux. However, this will be spontaneously regained upon the magnet's cooling back to ambient temperature. The Alnico materials have reversible variations on the order of 1/10 as great as ceramics, depending upon the material and the operating point on the demagnetization curve. Reversible variations are not eliminated by stabilization treatments. However, use of proper temperature composition material in parallel with the magnet will reduce the effect to a negligible factor. Among others, household watt-hour meter magnets and speedometer magnets are temperature compensated in this manner.

### **Reluctance changes**

If a magnet is magnetized in a magnetic circuit and subsequently subjected to permeance changes (such as changes in air gap dimensions or open-circuiting of the magnet) it may be found that a partial demagnetization of the magnet has occurred. Whether or not such a loss is experienced depends upon material properties and upon the extent of the permeance change.

Stabilization against such change is accomplished either by subjecting the magnet several times to reluctance changes after magnetizing, or by use of the previously described AC field.

Contacting the magnets with ferro-magnetic material (screw drivers, pliers and the like), at points other than the poles, can cause an appreciable drop in flux at the poles. It is difficult to stabilize against this type of abuse. The remedy is to avoid such practices.

### **Adverse fields**

If a magnet or magnet assembly is subjected to an adverse magnetic field, a partial demagnetization may result, depending upon material properties and the intensity and direction of the adverse field. Proper stabilization consists of subjecting the magnet or assembly to a DC or AC demagnetizing field of the same magnitude as it is expected to encounter in service. The direction should be the same as that of the anticipated demagnetizing field.

### **Shock, stress and vibration**

The effects of shock, stress and vibration (below destructive limits) on most permanent magnet materials are so minor that little consideration need be given to them. Proper stabilization as described in any of the preceding paragraphs will also stabilize against shock and vibration.

### **Radiation**

The effects of radiation on permanent magnet materials varies widely by material classes. Current experiments indicate that all permanent magnet materials of a commercial nature can withstand irradiation to  $3 \times 10^7$  neutrons per  $\text{cm}^2$  (neutron energies greater than 0.5eV), without flux changes. A majority of the commercial materials (including Alnico and Ceramic) can withstand  $2 \times 10^{18}$  neutron per  $\text{cm}^2$  exposure without flux changes, and show only minor changes (less than 10%) when the radiation level is increased to  $3 \times 10^{13}$  neutrons per  $\text{cm}^2$ .

Radiation, like thermal demagnetization, is not applicable to calibration. Some evidence indicates that secondary exposure to high neutron densities that caused initial flux changes resulted in only negligible additional flux changes. This would indicate that stabilization of radiation effects by initial exposure is possible.

### Handling of Permanent Magnets

In many instances, the permanent magnet remembers what was done to it or what environment it was exposed to. Adverse factors affecting permanent magnets must be acknowledged and techniques applied to minimize or eliminate these conditions. The design, manufacture, handling and processing of permanent magnets is based on adequate control of this sequence to insure optimum performance in the final application. Improper handling has resulted in poor, or completely sub-standard, performance.

### Unmagnetized magnets

From the standpoint of ease in shipping, handling and storage, the unmagnetized magnet is preferred. Special problems of knockdown, iron chip pickup, and special instructions on handling to personnel are eliminated.

To insure magnetic quality, the permanent magnet supplier has to test the magnet in a fully magnetized condition. After this inspection, the magnet is demagnetized prior to shipment.

The benefit of purchasing, shipping and processing of unmagnetized magnets are many. A few of the problem areas that can be eliminated or minimized are:

- Keepers are not required
- Proximity effects of other permanent magnets may be ignored
- Proximity of strong AC or DC fields pose no problem
- Physical shock or vibration for critical applications may be ignored
- Shape problems of self-magnetization are not applicable
- Physical handling problems are considerably alleviated
- Storage and shipment problems are minimized

A final step must be performed to an unmagnetized permanent magnet: magnetizing and inspecting the functional magnetic field of the permanent magnet after assembly. Adequate means for saturation and control of the magnetizing process for the permanent magnet is needed. In some cases, stabilization must be included for temperature, AC or DC electric fields and/or other effects.

### Magnetized permanent magnets

If a permanent magnet is purchased magnetized, what does or can occur magnetically must be realized. The concept of magnetic behavior, or operating slope for maximum magnet efficiency must be recognized. The accrued factor of self-demagnetization, or **built-in** stabilization, must be evaluated. The problem of in plant processing cannot be overlooked. Also, the problem of shipping a number of magnetized magnets and their attractive forces, along with temperature extremes, must be considered.

This magnetized condition, and its associated problems, can be alleviated by specifying that keepers be attached. A keeper is simply one or more pieces of ferrous material usually placed across the gap of a magnetized permanent magnet. The use of a keeper reduces stray leakage fields for better handling and less magnetic interaction among magnets.

Personnel who handle magnetized magnets and assemblies should receive special instructions. This details what should or should not be done to the magnetized assemblies. As an example, the dropping of a permanent magnet structure may alter the gap dimensions. This could occur without any visible damage to the structure, but would necessitate demagnetizing the permanent magnet, reworking the structure, and remagnetization. In many cases, the removal of a magnetized permanent magnet from its structure will degrade the performance, resulting in a **knockdown** of the permanent magnet, a condition remedied only by remagnetization.

The previous discussion for the two states of a permanent magnet – magnetized or not magnetized – are, of necessity, quite general. The user will have specific problems, which in many cases will require a unique procedure. This information should be obtained from the supplier.

## **Magnetization**

Basically, magnetization requires subjecting the magnet to an uni-directional magnetic field of proper strength and direction. A power source with some type of control and a magnetizing fixture are the important elements. There are many ways to produce the magnetizing field required to magnetize magnets, magnet circuits or assemblies. These may range from a simple solenoid to an elaborate water-cooled one-half cycle pulsed transformer magnetization system. An evaluation of the best approach considers such factors as magnet material and shape, type of assembly, and production processes. In fact, many magnet designs and/or assembly processes are influenced by the availability of proper magnetizing equipment.

### **Permanent magnet method**

A permanent magnet may providing the necessary magnetizing field. However, this method is used only for small, simple shaped magnets. This method, while inexpensive and requiring no power source, is generally unacceptable. This is due to the possibility of inadequate magnetizing field strength, difficulty of removing the magnetized magnet from the magnetizer, distortion of the magnetizing field (caused when the magnet is removed) and the fact that magnetic particles attracted to the magnetizer are difficult to remove.

### **Electro-coil method**

DC coils with or without iron cores and water cooling can be used to produce magnetizing fields. This method is probably the most common approach to general magnetization. Normally the magnetizers are used in an intermittent basis. Coils with steel cores are used with a rectified AC power source. These units are adaptable for the simple-shaped permanent magnet including rods, bars, and U-shaped configuration. Their major disadvantages are the difficulty in obtaining proper magnetizing field direction in complicated magnet designs and the relatively slow magnetization rate due to coil inductance.

### **Capacitor discharge method**

This approach uses the energy stored in a capacitor bank. Since magnetization is essentially instantaneous, a magnetizer system is only required to supply the proper value of magnetizing pulse for a very short interval of time. The amplitude is dependent upon that required to saturate the magnet and the duration that is necessary to overcome the eddy current and hysteresis effects of the pulse of the magnet, its associated circuitry and the magnetizing system itself. Capacitor discharge units can also be used with high current pulse transformers.

The advantage of capacitor discharge systems is the energy can be put into the storage system (capacitors) at a relatively slow rate so that the power demand is low. However, this means that charging or reset time could be an undesirable factor in fast repetitive operations.

### **One-half cycle method**

The one-half cycle magnetizer is a half-wave rectifier connected between an AC source and the magnetizing coil. Control circuitry assures a unidirectional high current pulse of one or more cycles. Proper phasing controls the energy of the magnetizing pulse. The one-half cycle magnetization system is ideal when used with a properly designed pulse transformer and matched magnetizing fixture. Extremely fast magnetizing cycles are possible because, at least in theory, it is possible to magnetize once every cycle. However, magnet handling consideration and coil and fixture heating are the limiting factors. With the practical adaptation of this type of system, the magnetization operation is no longer a bottleneck. Ingenious air and water cooling of the magnetizing fixtures, pulse transformers, and other parts of circuitry have led to high operational rates.

### Testing systems

There are many ways to test permanent magnets. A flux sensing device combined with a readout method is required. Each application must be evaluated to determine what approach best fits the situation. Flux meter and ballistic galvanometer equipment have been used for many years. The magnetometer, permeameter, coercimeter, and gauss meter all play an important role in determining and evaluating magnetic characteristics of permanent magnets, especially for engineering design evaluation.

The introduction of stable, sensitive, commercially-available Hall probes has made possible magnet production testing that is accurate, fast and reliable. The simplest form of a Hall probe is the Calibrated Hall Element discussed in Chapter 3. These probes, when energized with a constant control current or voltage, give a voltage output proportional to the strength of magnetic field. Consequently, the Hall probe with voltage sensor relays or readout devices is the heart of modern permanent magnet testing. Experience indicates that properly designed test systems can give results approximating laboratory accuracy.

It is important to obtain absolute values of magnetic parameters for engineering evaluation to prove the design. In this case, equipment is calibrated to give this information. Generally, however, production testing of permanent magnets is done on a comparative basis.

A reference magnet that gives known performance is used. The testing method and circuit is designed to be equivalent, as far as the magnet is concerned, to actual operating conditions. Normally, it is not necessary in production testing to investigate the entire demagnetization curve. Most production tests are designed to indicate the magnet's quality at its operating condition.

### Calibration systems

On occasion, consideration must be given to calibrating magnets or magnet assemblies. The decrease in the range of flux variation from magnet to magnet will result in an end product having greater performance uniformity. A careful analysis of all the factors will indicate if calibration should be considered.

It is first necessary to determine the strength of the magnet or magnets in the assembly. A comparison with the required level and the allowable variation will indicate if calibration is necessary. If so, the unit is demagnetized to the prescribed level of flux output. This is done by controlled demagnetizing pulses that partially demagnetize the magnet, thus decreasing the flux output.

AC fields and capacitor discharge systems having manual or automatic controls are also being used successfully in calibrating systems. These and even electro-coil methods have been used in laboratory work. The one-half cycle system will give the fastest rate for volume calibration of permanent magnets. Circuitry has been developed that will precisely control the synchronization and phasing of ignitron tubes to give fast, repetitive and controllable calibrating pulses.

### Magnetic materials

Most permanent magnet materials commercially available today have been available for many years. These basic materials have become identified with a standard name and number identifiable throughout the permanent magnet industry.

MMPA Standard 0100-66 that is published by the Magnetic Materials Producers Association, Chicago, lists commercially available permanent magnet materials. The publication presents nominal chemical composition and typical magnetic properties. A material specification submitted to any permanent magnet manufacturer need only designate the name - Alnico 5, Ceramic 1, Cunife, Sintered Alnico 2, etc. - in order to specify a particular permanent magnet material. The same MMPA Standard has been accepted by the Department of Defense in place of Military Specification QQ-M-60 for Permanent Magnet Materials.

**Magnetic characteristics**

In general, every cross section of an ideal magnet in a fixed gap circuit should operate at the maximum energy point shown in Figure B-6. In practice, this is usually not the case. In a good design, the majority of the magnet materials operate in the vicinity of the maximum energy point - Point 2, on the knee of the B-H curve. Small variations in  $B_r$  and  $H_c$  from magnet to magnet will have little or no effect upon the output of the magnet and its circuit.

If the magnet is operating above the knee of the B-H curve (Point 1), variations in  $B_r$  would affect the output, but variations in  $H_c$  would not. If the magnet is operating below the knee of the curve (Point 3), the opposite is true. If one of these conditions applies, the magnet manufacturer may modify processing to favor that condition so that magnet performance in the customer's product will be improved. Consequently, to achieve a satisfactory product, it is sufficient to tie down only those parameters that apply to a given magnetic circuit.

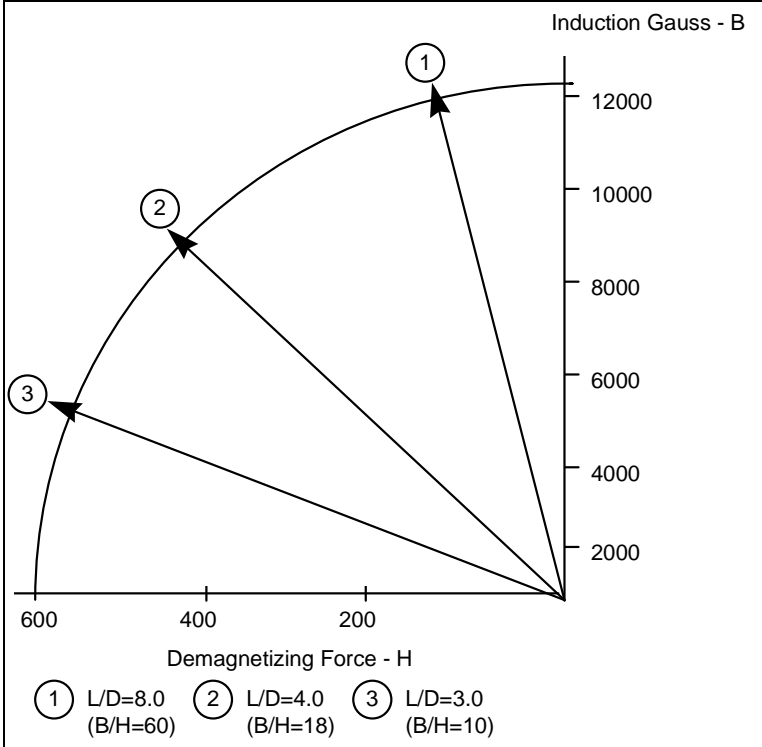

Figure B-6 Demagnetizing curve Alnico 5

### Practical magnet specifications

As opposed to the sophisticated magnet theory and other magnet design principles that are of importance mainly to magnet manufacturers, practical magnet specifications involves a basic knowledge of magnet materials, magnetic characteristics, magnet test procedures, and factors that affect flux produced by a magnet. A disciplined application of these considerations simplifies correct magnet specification.

A user-formulated specification that is too light may require the magnet manufacturer to provide extra manufacturing, testing and quality control operations. In many cases, magnets perfectly suitable for the end product may be scrapped because of unrealistic specification. As a result, specifying too tightly increases the magnet's cost.

On the other hand, a loose specification (or no specification) could allow the shipment of almost any magnet grade. Such a situation would not be desirable for either user or supplier. In addition to magnetic properties, specifications on surface finishes or physical dimensions are important.

# Appendix C

# Magnetic Curves

## Introduction

MICRO SWITCH Sensing and Control is not a manufacturer of magnets, but does offer a number of magnets (with and without mounting provisions) for use with Hall effect sensors. Few, if any, magnet suppliers are willing to specify flux (gauss levels) at some given distance from the magnet, however, MICRO SWITCH Sensing and Control does. Available flux is a critical factor in operating Hall effect sensors.

The most common magnet for operating Hall effect sensors is a bar magnet. For head-on actuation, there should be sufficient magnet travel to provide at least 10% overdrive of both Max. Operate and Min. Release characteristics of the sensor. For slide-by actuation, the magnet should pass the sensing surface at a distance that provides at least 10% overdrive above Max. Operate.

Ring magnets are another means of operating sensors. These magnets are magnetized on the outside diameter with alternating

north and south poles. Each pole pair (N and S) produces one pulse with standard devices. Ring magnets are particularly useful with bipolar sensors, which require both south and north poles be presented to the device face.

The graphs included in this section are plots of gauss versus distance for some typical magnets. The magnetic curves were developed using a 732SS21-1 calibrated Hall device which is no longer available and a X98834-SS calibrated Hall device. See Appendix D for details on how to use a calibrated Hall device.

## Head-on mode magnetic characteristics

Figures C-1 through C-11 illustrate graphs of the magnetic flux (gauss) at the sensor, versus distance (inches) for various magnetic material in the head-on mode of actuation. The magnet's axis is oriented perpendicular to the surface of the sensor and centered over the point of maximum sensitivity. The direction of movement is directly toward and away from the sensor with the magnetic lines of flux passing through the center of the device. The magnet is oriented so the S pole of the magnet will approach the sensitive face of the sensor. The graphs show that the magnetic field strength increases exponentially as the magnet approaches the sensor. All measurements are at 25°C.

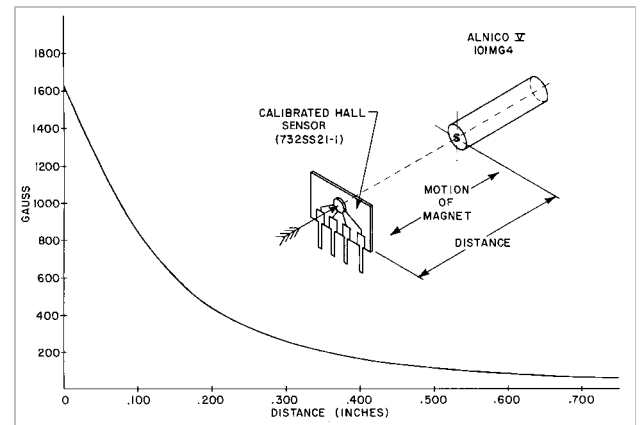

Figure C-1 Alnico V 1.25" x .25" dia. Calibrated magnet (420 gauss @ .205"). Can be used for either digital or linear applications

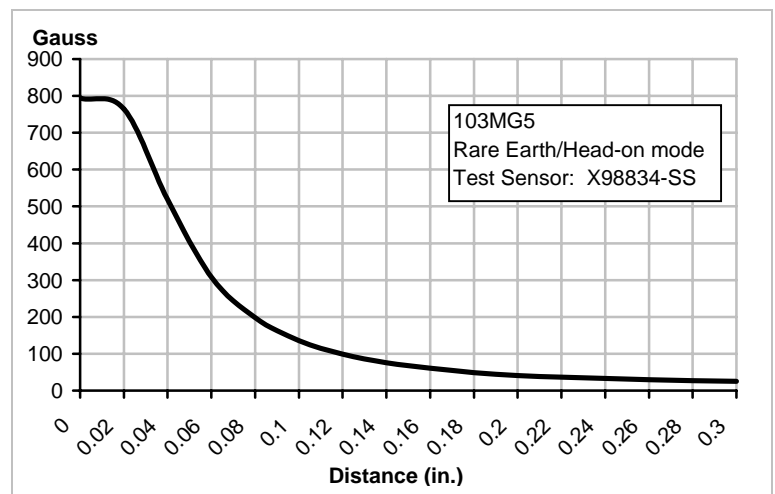

Figure C-2 Rare earth .078" sq. x .040" thick magnet. Can be used for either digital or linear applications; a bias magnet is recommended.

# Appendix C • Magnetic Curves

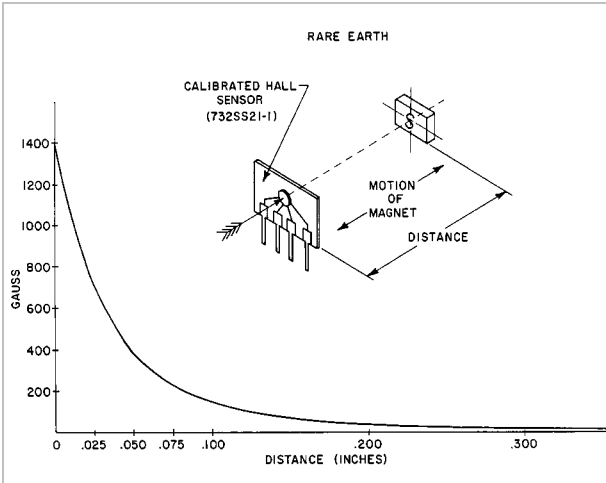

Figure C-3 Rare earth .125" x .078" x .040" thick magnet

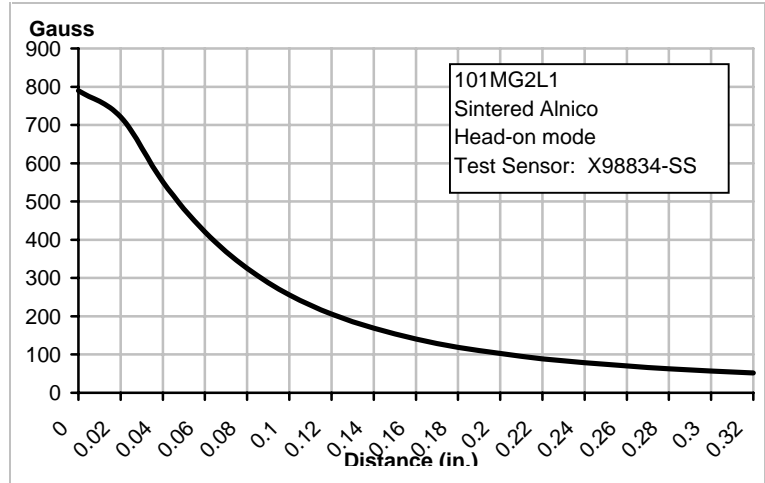

Figure C-4 Sintered Alnico 37 .375" x .125" magnet. Can be used for either digital or linear applications

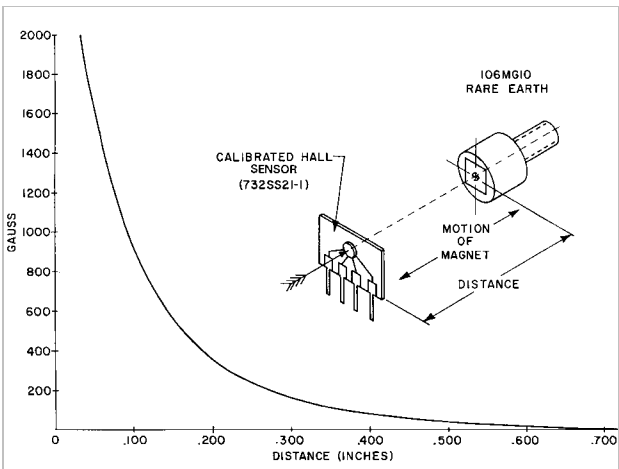

Figure C-5 Rare earth .22" sq. x .20" long magnet in threaded actuator. Can be used for either digital or linear applications

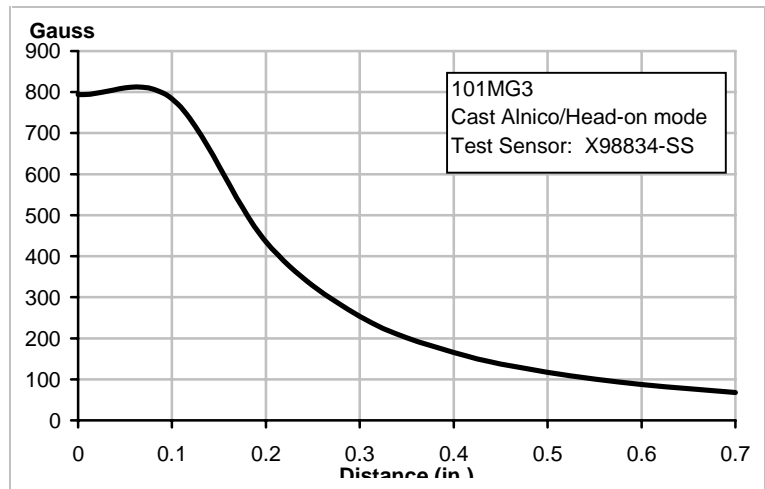

Figure C-7 Cast Alnico 1.25" x .25" dia. magnet

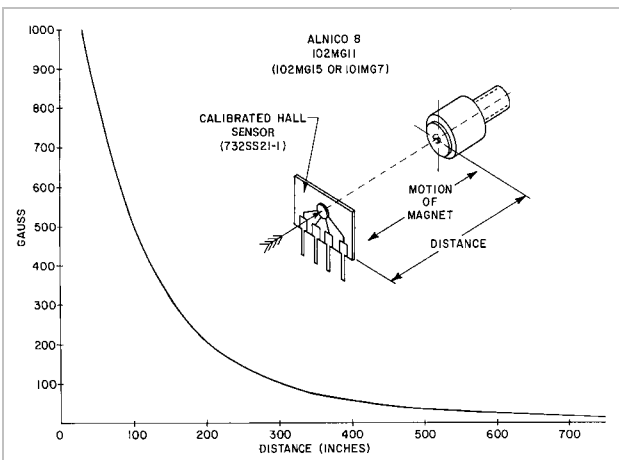

Figure C-6 Alnico VIII H.E. .25" x .25" dia. magnet in threaded actuator. Recommended for linear applications

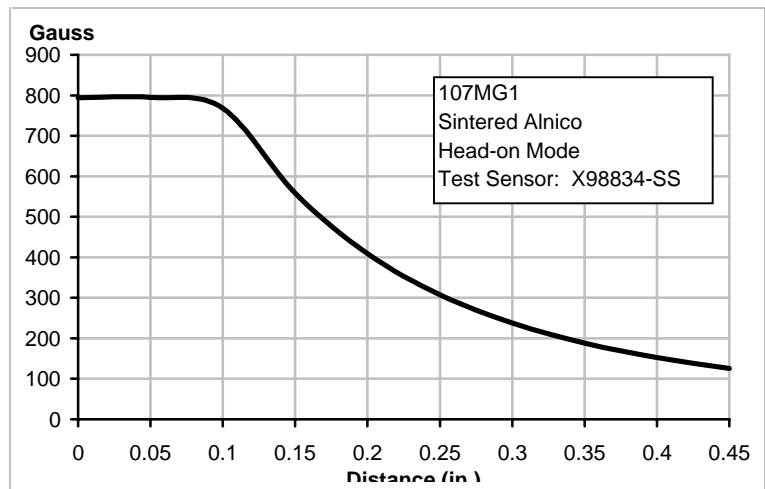

Figure C-8 Sintered Alnico .600" x .325" dia.



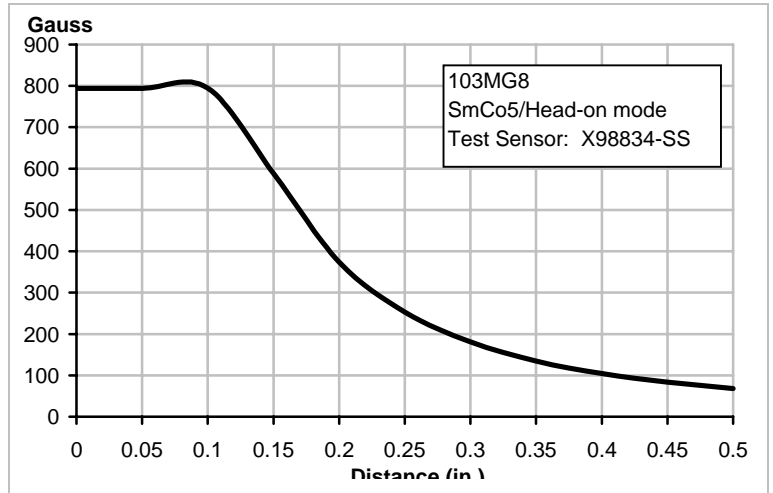

Figure C-9 SmCo5 .22" sq. x .2 in. thick

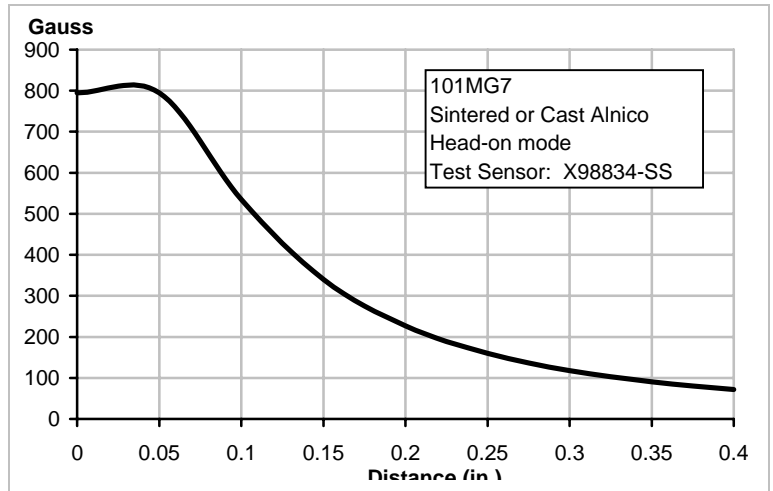

Figure C-10 Sintered or Cast Alnico .250" x .250" dia.

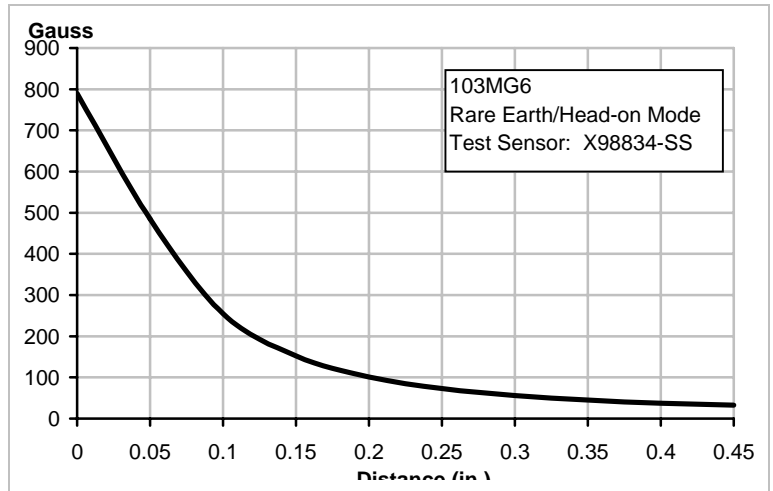

Figure C-11 Sintered Rare earth .08" sq. x .120" thick

Slide-by mode magnetic characteristics

Figures C-12 through C-26 illustrate graphs of the magnetic flux (gauss) at the sensor, versus distance (inches) for various magnetic materials in the slide-by mode of actuation. The magnet's axis is oriented perpendicular to the surface of the sensor and is moved across at some constant gap distance. In addition to the obvious advantage of never placing the sensor in any danger of being physically struck, slide-by will typically result in a lower differential (distance from operate to release) than occurs in head-on mode for the same magnet. All measurements are at 25°C.

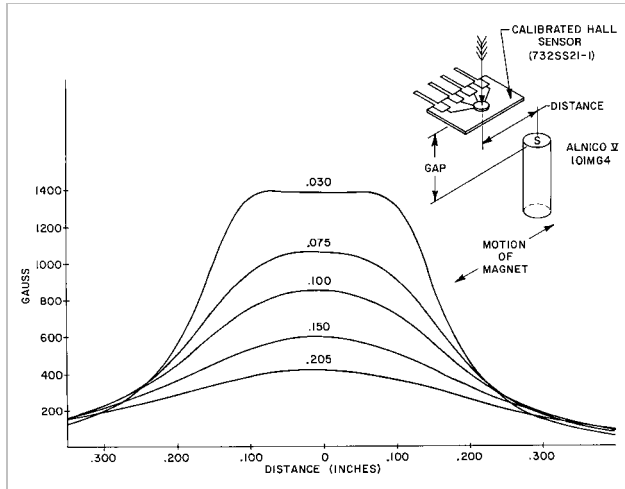

Figure C-12 Alnico V 1.25" x .25" dia. calibrated magnet (420 gauss @ .205")

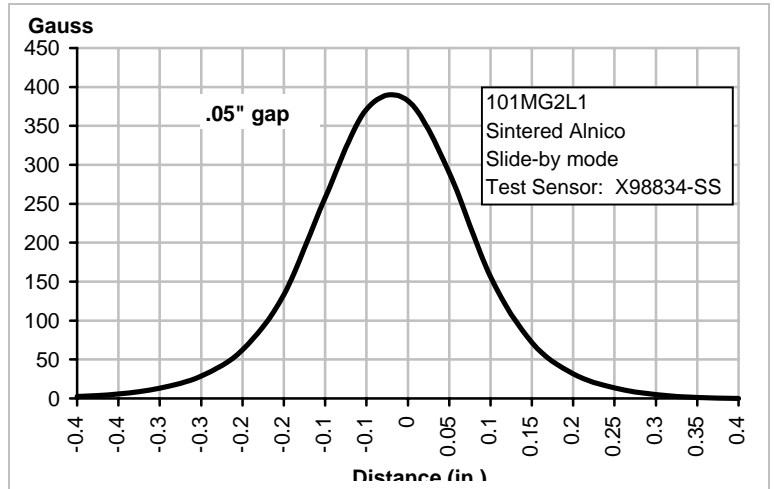

Figure C-13 Sintered Alnico 37 .375" x .125" magnet

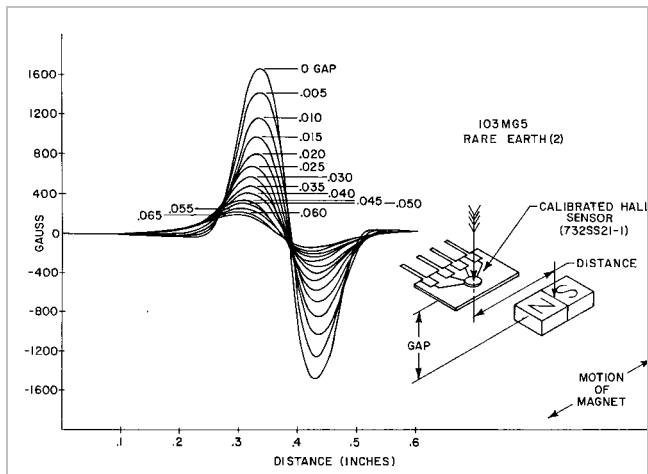

Figure C-14 (2-side by side) Rare earth .078" sq. x .040" thick magnet

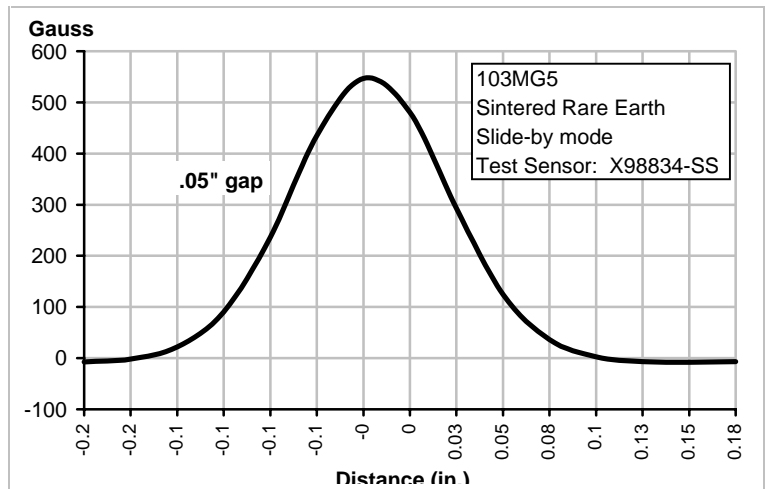

Figure C-15 Rare earth .078" sq. x .040" thick magnet

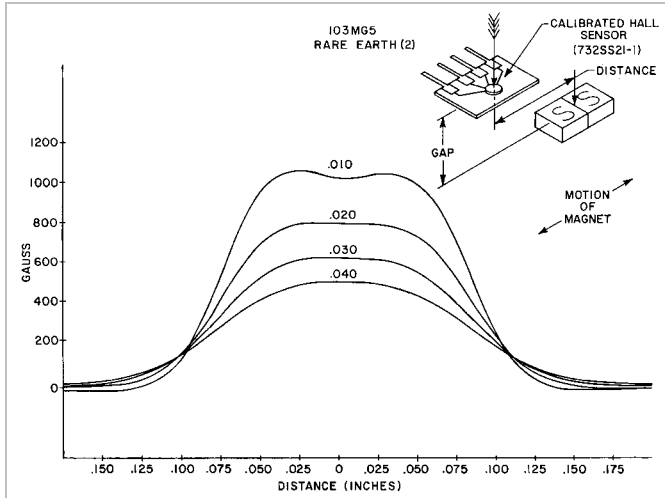

Figure C-16 (2) Rare earth .078" sq. x .040" thick magnet

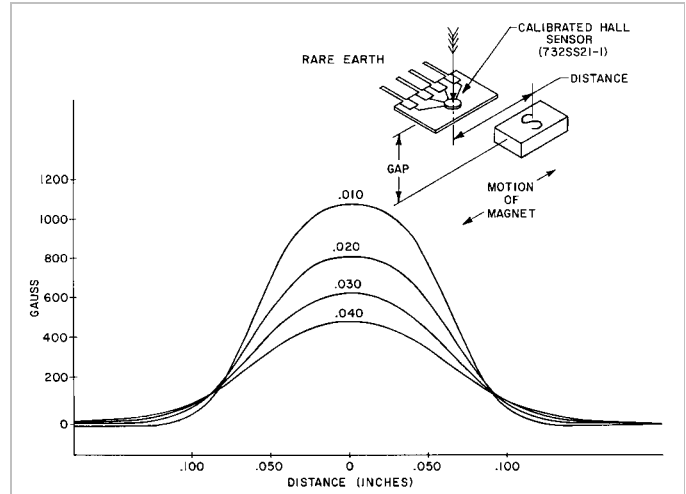

Figure C-17 Rare earth .125" x .078" x .040" thick magnet

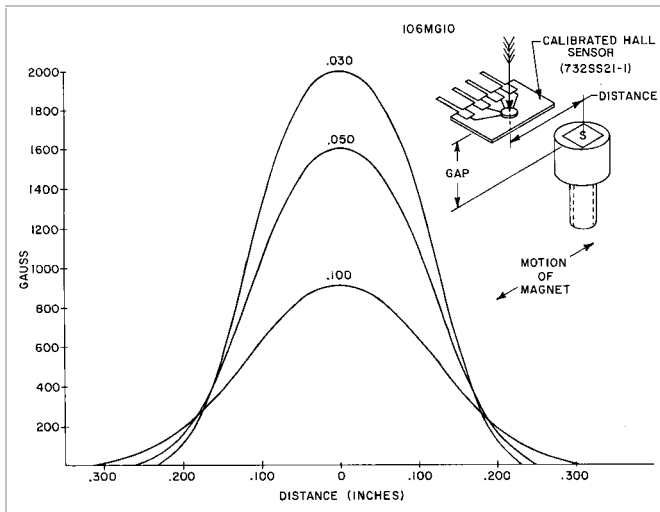

Figure C-18 Rare earth .22" sq. x .20" long magnet in threaded actuator

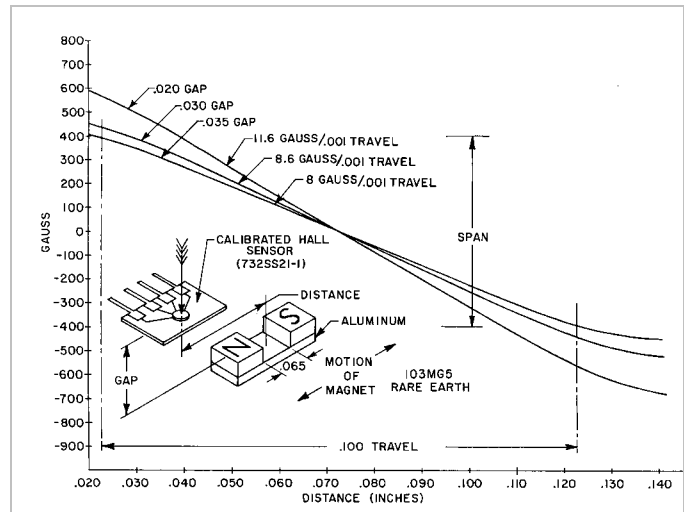

Figure C-21 (2) Rare earth .078" x .040" thick magnet. Recommended for linear applications.

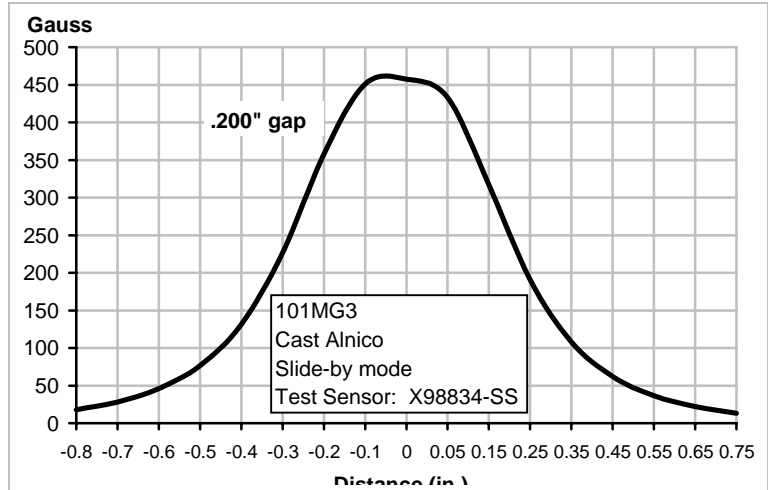

Figure C-22 Cast Alnico 1.25" x .25" dia.

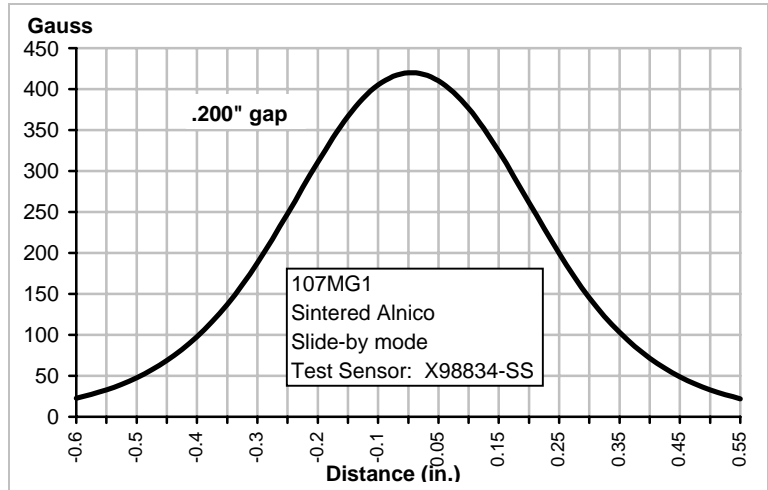

Figure C-23 Sintered Alnico .600" x .325" dia.

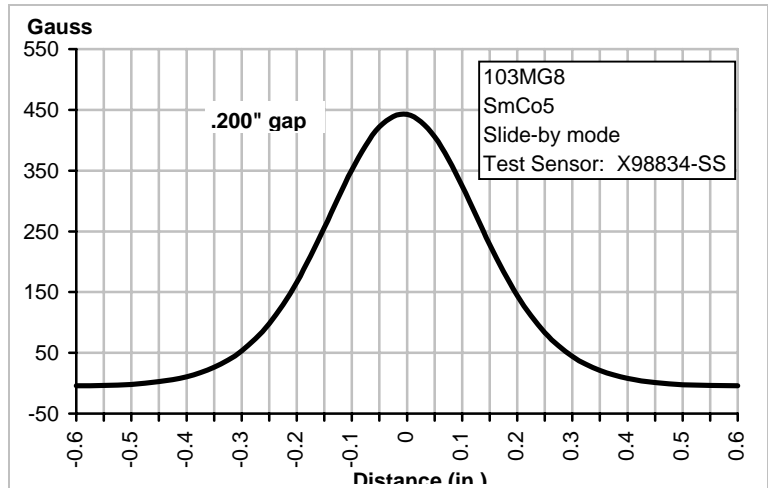

Figure C-24 SmCo5 .22"sq. x .20" thick

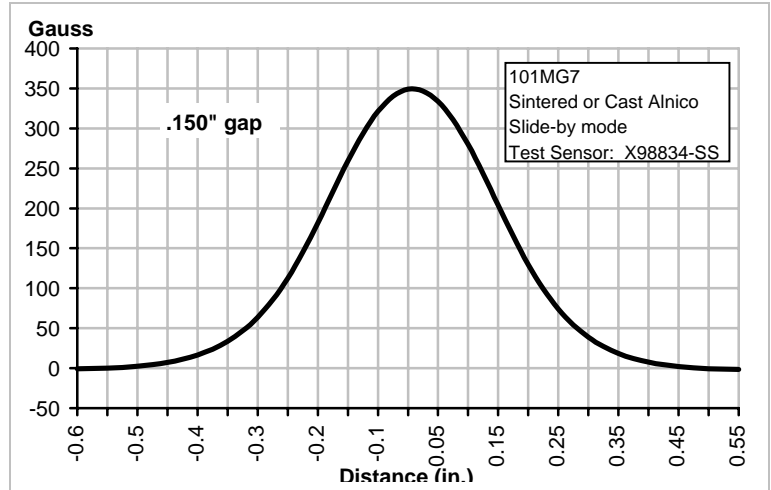

Figure C-25 Sintered or Cast Alnico .250" x .250" dia.

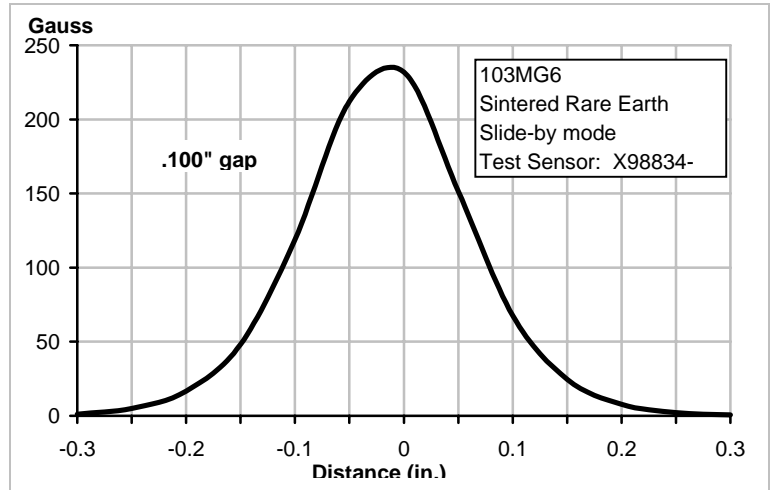

Figure C-26 Sintered Rare earth .080" sq. x .120" thick

Rotary mode magnetic characteristics

Figures C-27 through C-30 illustrate graphs of the magnetic flux (gauss) at the sensor, versus degrees of rotation for various ring magnets. The curves were developed at various gap distances from the surface of the calibrated Hall device. The magnets were centered over the point of maximum sensitivity. The gauss levels illustrated are worst case. Higher levels may be achieved with calibrated devices that utilize flux concentrators. Note how the gauss levels for the various magnets decrease with the number of pole pairs. That is, as the mass of the magnetic material per pole decreases, the peak flux decreases. All measurements are at 25°C.

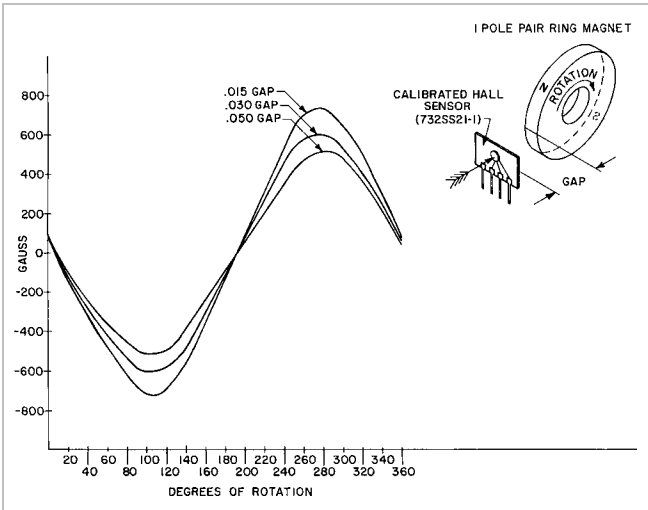

Figure C-27 Ceramic .75" dia. (3/8" mounting hole) ring magnet. Recommended for linear applications

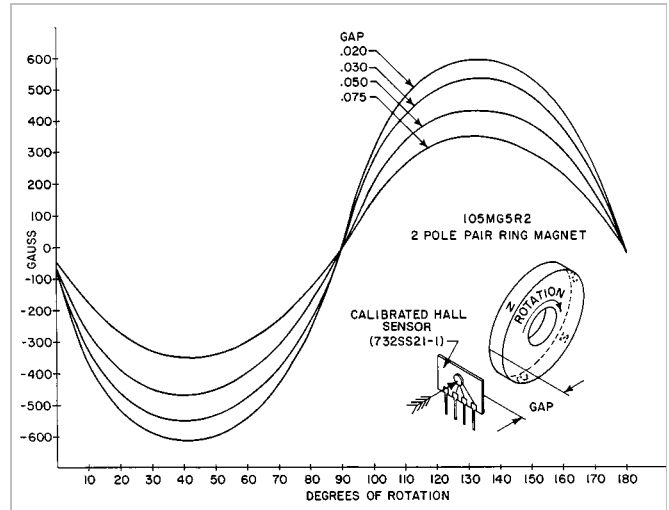

Figure C-28 Incox .625" dia. x .20" thick ring magnet

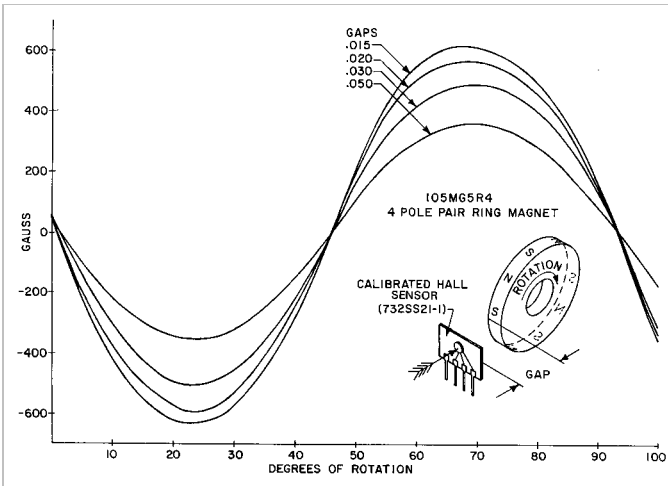

Figure C-29 Incox .625" dia. x .20" thick ring magnet

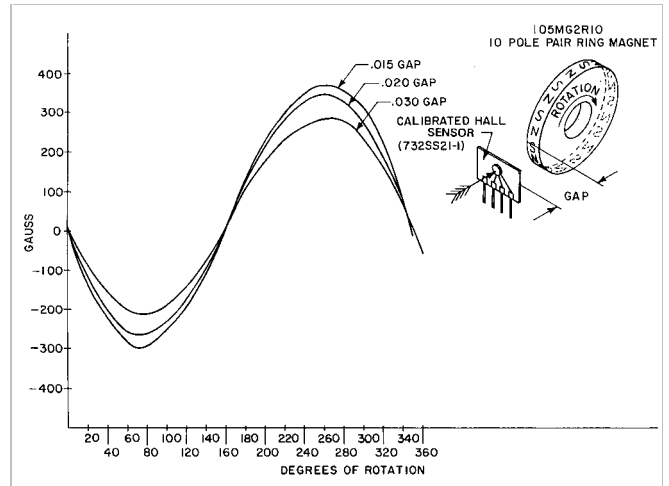

Figure C-30 Lodex 42 1.75" dia. x .14" thick ring magnet

**Toroid core magnetic characteristics**

Figures C-31 through C-34 illustrate graphs of magnetic flux (gauss) at the sensor, versus ampere-turns for various toroid cores. When choosing toroid cores, choose ferrite (magnetic ceramic) over tape (wound electrical steel) if fast response or high frequency is required or where minimum offset and hysteresis is needed. Use tape for currents over 200 amperes.

The diameter of the core will effect the location of the knee. If it is larger, the knee will be higher. If it is smaller, the knee will be lower. The cross-sectional area is not important as long as it is large enough to cover the sensor. Also, the position of the wire in the toroid is not critical with small gaps. Making the gap larger reduces the gauss per ampere, but tends to make it less linear, thus the position of wire becomes more critical. One wire through the core with 100 amperes produces the same effect as 100 turns with 1 ampere.

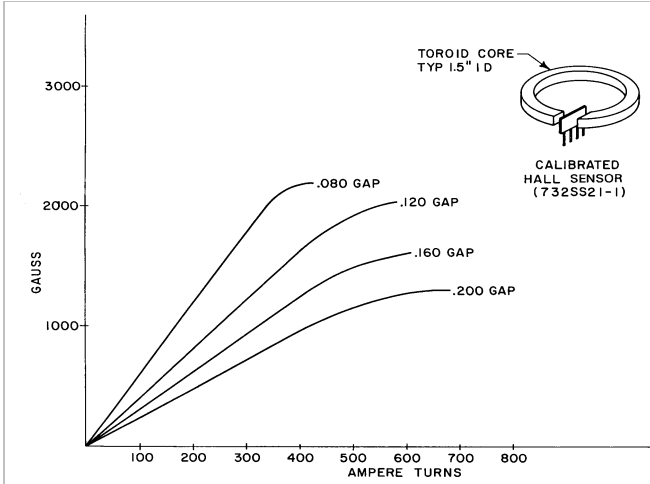

Figure C-31 Effect of gap on typical tape toroid core

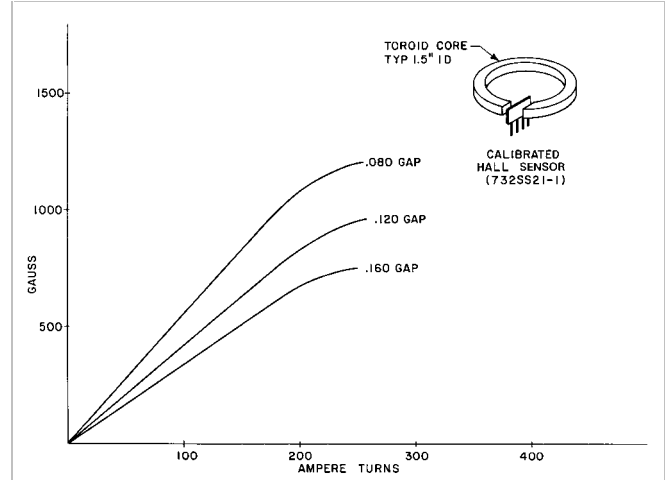

Figure C-32 Effect of gap on typical ferrite toroid core

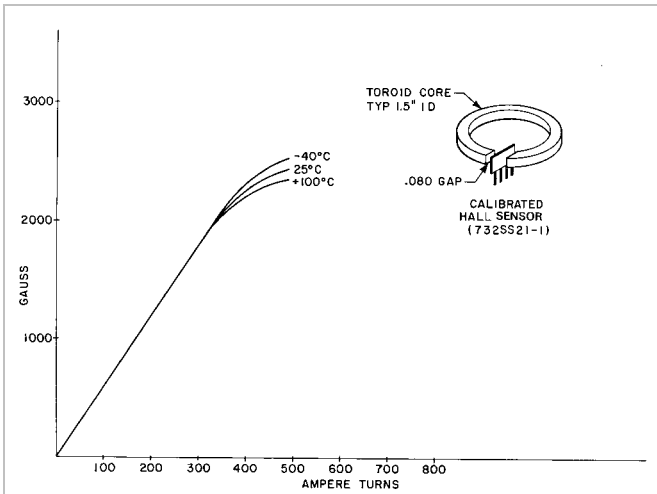

Figure C-33 Effect of temperature on typical tape toroid core with .080" gap

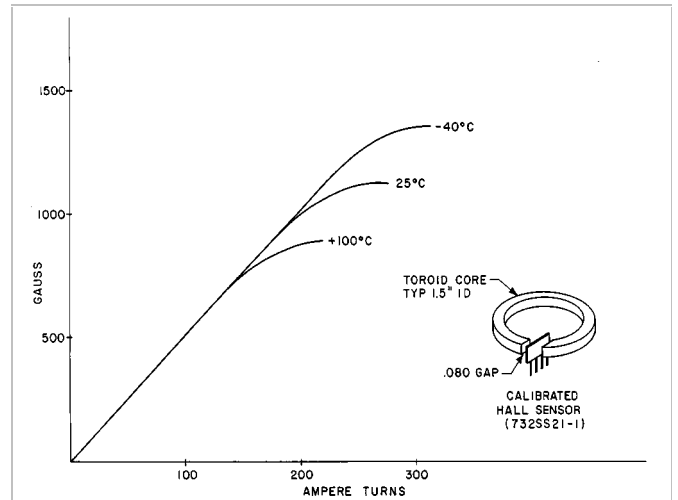

Figure C-34 Effect of temperature on typical ferrite toroid core with .080" gap

### Purchasing magnets

When specifying a magnet based on reading a particular level of gauss (as determined by the Hall sensor), it is important that the magnet vendor specify his magnet the same way. Specify exactly what the magnet should do using the Hall device. Most magnet suppliers will work with buyers to supply the magnets desired. Incoming inspection should have the capability to verify that a particular magnet does meet the specified requirements.



# How to use the X98824-SS Calibrated Hall Device

### Description

Magnetic characteristics for Hall effect devices are specified within particular ranges. To insure that all devices will operate and release in the application, gauss levels should be verified. The calibrated Hall device will allow the user to measure the gauss levels produced in the application. Calibrated devices are intended for laboratory use only. Any application of a magnetic sensor requires a thorough understanding of the magnetic gauss levels and how they change. The calibrated Hall device is used to determine the flux density produced at the sensor by the magnet.

The X98834-SS calibrated Hall device provides an output proportional to magnetic flux densities. This device is supplied with an accurate, individual plot of output voltage versus gauss (calibration data). A millivoltmeter with ungrounded input terminals and a  $1\text{M}\Omega$  minimum input impedance was used to measure the output voltage. In order for the calibration data to be accurate, a stable, precise power supply was used ( $5 \pm .003\text{VDC}$ ) and a temperature of  $24 \pm 2^\circ\text{C}$  was maintained. A  $2.2\text{K}\Omega$  resistor connected between output and minus terminals was used as the load during calibration.

An output voltage (null offset) exists when no magnetic field is present. This offset voltage is a result of a mismatch of the internal connections to the Hall element and is accounted for in the calibration data. Measure the null offset voltage at  $24^\circ\text{C}$  with an  $5.000\text{VDC}$  power supply and a  $2.2\text{K}\Omega$  resistor after a 15 minute warm-up period. If the null offset voltage measured with the application's equipment is different from the one shown in the calibration data, use your value to get the most accurate gauss measurements in your application.

Mount the calibrated Hall device and magnet(s) with provisions for moving the magnet(s) in known increments. A micrometer and increments of 0.025 inch (0.6mm) are recommended. If pole pieces or flux concentrators will be used in the magnetic system, they must be included during measurement. Initial measurements should be made in the head-on mode. The magnetic curves for this mode are not only useful for head-on sensing, but also for determining the effect of gap distance and pole piece effect for other modes.

Move the magnet toward the package using the head-on mode of operation. If the set-up is correct, the millivolt reading will increase. However, if the magnet polarization is incorrect, the reading will be positive, but will begin moving towards negative as the magnet approaches the package. In this case, reverse the magnet. Continue moving the magnet until it is touching the device package face evenly. This will provide the maximum reading in millivolts and the maximum induction available from the magnetic actuator.

## Appendix D • How to use the X92755-SS Calibrated Hall Device

---

When the magnetic field decreases, the output voltage decreases in a like manner. Referring to the calibration data supplied, a reading on the voltmeter is easily converted to gauss. Mechanical characteristics can be verified by first plotting a gauss versus distance graph. By comparing the curve to the magnetic characteristics of the sensor, the possible mechanical ranges of operate point and release point can be determined.

Once the operating limits of the magnet and sensor combination have been established, feeler gages, etc. may be used during installation to insure that the correct gap is maintained. The X98824-SS calibrated Hall device remains linear over a span of -600 gauss to +600 gauss. Using this device allows a thorough analysis of a mechanical/magnetic system. This information is needed to determine system reliability and tolerances.

# Comparison of Hall Effect and MR Technologies

## Description

The following table compares the Hall effect in silicon to magnetoresistance in a nickel-iron thin film.

1. Both technologies are compatible with integrated circuit processing and may be used to make totally integrated single-chip sensors.
2. MR is roughly 200 times more sensitive than the Hall effect in silicon. Furthermore, it is adjustable through selection of film thickness and line width.
3. The Hall effect is highly linear with no saturation effects out to extremely high fields.
4. The Hall effect occurs for fields applied perpendicular to the plan of the all element. The magnetoresistive effect occurs in the plane of the thin film perpendicular to the long direction of the resistive elements.
5. Both effects occurs for time-invariant fields and may be used to construct zero speed sensors.

## Magnetoresistive vs. Hall Effect

	Hall	MR
Process Technology	Silicon IC	NiFe Thin Film
Sensitivity	10uv/v/g	2 mv/v/g
Saturation Field	None	10 - 100g
Linearity	< 1%	$\text{COS}^2 \theta$
Sensitive Axis	Perpendicular to plane of chip	Parallel to plane of chip
Output for Constant Field	Yes	Yes



# Glossary

## -A-

**Absorption** - The taking in of a fluid to fill the cavities in a solid.

**AC** - See alternating current.

**Accelerometer** - A sensor used to measure acceleration or gravitational force

**Accuracy** - The extent the output of a SENSOR approaches the true value of the quantity being measured.

**Active Elements** - Those components in a circuit that have signal power gain; transistors, SCRs, etc.

**Admittance** - The reciprocal of the impedance of a circuit.

**Alignment** - Placing the light source and photoreceiver (or reflector) so as to direct the maximum amount of light on the photosensor.

**Alnico** - A family of permanent magnet alloys generally containing aluminum, nickel, cobalt, and iron. Material can be found both in cast and sintered form, including isotropic and anisotropic alloys.

**Alternating Current** - An electric current that is continually varying in value and is reversing its direction of flow at regular intervals, usually in a sinusoidal manner.

**Ambient Temperature** - The average temperature of the surrounding medium, i.e. air, water, or earth to which the heat of a device is dissipated.

**Amp** - See Ampere.

**Ampere** - The standard unit for measuring the strength of an electric current. Rate of flow or charge in a conductor of one coulomb per second.

**Ampere-Turns (NI)** - MKS unit of magnetomotive force.

**Ampere's Law** - One of the basic relations between electricity and magnetism that states quantitatively the measure of a magnetic field in terms of electric current or changing electric calculus: the line integral of the magnetic field around an arbitrarily chosen path is proportional to the net electric current enclosed by the path.

**Amplification** - The production of an output larger than the input.

**Amplifier** - A device whose output is an enlarged reproduction of the input signal.

**Analog** - Having the property of being continuously variable, as opposed to having discrete states.

**Analog Switch** - A solid state device capable of switching voltages or currents bilaterally in response to a digital control signal.

**Anisotropic Magnetic** - A material having preferred orientation. The magnetic characteristics are better along one axis than along another. This may be as a result of rolling, heat treatment in a magnetic field, or in the case of some of the sintered magnets, the direction of the press.

## Glossary

---

**Anode** - The terminal by which current enters to diode, or the one that is positive with respect to the other when the diode is biased in the forward direction.

### -B-

**B** - See Magnetic Flux Density.

**Barium Ferrite** - The general term given to a class of magnets having the composition  $BaFe_{12}O_{19}$ . The material may be held together with a ceramic, plastic or rubber binder.

**Bellows** - A mechanical pressure sensing element consisting of a metallic bellows with a plate on one end. Pressure applied to the open end causes the plate to move. The amount of movement becomes a measure of applied pressure.

**Best Straight Line (BSL)** - The best straight line chosen so that a true sensor response curve contains three points of equal maximum deviation.

**B-H Curve** - See Magnetization Curve.

**Bias** - The electrical, mechanical or magnetic force applied to a device for the purpose of shifting a reference level.

**Bimetallic Thermometer** - A strip of two metals having different coefficients of expansion bonded together in the form of a spiral or helix. Movement caused by a temperature change becomes a measure of temperature.

**Bipolar (semiconductor)** - A semiconductor process for fabricating PNP or NPN transistors.

**Bipolar Magnetic System** - A magnetic system where the direction of the magnetic field, at the point being considered, changes its polarity (plus to minus or minus to plus) as a function of time or motion of the system.

**Bipolar Sensor (Hall Effect)** - A sensor whose maximum operate value is a positive gauss level and whose minimum release value is a negative gauss value. A gauss level is considered positive if its direction is the same as the reference direction of the sensor.

**Bounce Buffer** - The electronic circuitry used to eliminate the effects of bounce of mechanical switch contacts.

**Bourdon Tube** - A mechanical pressure sensing device consisting of a curved or twisted metal tube that has a flat cross-section, and is sealed at one end. Pressure applied to the open end causes the tube to attempt to straighten. The resulting movement or resisting force is a measure of the applied pressure.

**Breakdown Voltage** - The reverse bias voltage applied to a PN junction where large currents are drawn for relatively small increases in voltage.

**Bubbler System** - A level measuring system that introduces a stream of air or gas bubbles into a liquid through a vertical dip tube. The pressure required to maintain the bubble flow is a measure of level.

### - C -

**Calibration** - A test where known values of measurands are applied to the sensor and corresponding output readings are recorded.

**Capacitance** - The property of an electric nonconductor that permits storage of energy.

**Capacitance Level Detector** - A device with single or multiple probes based on the fact that change in level causes change in probe capacitance.

**CGS System** - A system of measurement where the centimeter, gram and second are fundamental units.

**Charge** - Electric charge, like mass, length and time, is accepted as a fundamentally assumed concept, required by the existence of forces measurable experimentally. The unit is the coulomb.

**Chip** - A semiconductor material (silicon, sapphire, germanium, etc.) containing one or more active components.

**Circuit** - An arrangement of one or more complete paths for electron flow, (electronic circuit) or lines of flux (magnetic circuit).

**Circuit, Closed Magnetic** - A circuit where the magnetic flux is conducted continually around a closed path through low reluctance ferromagnetic materials; for example, a steel ring or toroid core.

**Circuit, Open Magnetic** - When a magnet does not have a closed external ferromagnetic circuit and does not form a complete conductive circuit in itself, the magnet is said to be open-circuited. For example, a horseshoe permanent magnet not having a keeper, although when "open", the path is continuous.

**CML** - See Current Mode Logic.

**CMOS** - See Complementary Metal Oxide Semiconductor.

**Coercive Force,  $H_C$**  - The magnetizing field that must be applied to a magnetic material in a direction opposite to the residual induction to reduce the flux density to zero (the value of H when B equals zero). One of several parameters used to describe a permanent magnet material.

**Coercivity** - The maximum value of the coercive force.

**Common Mode Voltage** - The voltage common to two points of an ungrounded network.

**Comparator** - A device with a digital output that indicates which of the two analog inputs is greater.

**Compensated Temperature Range** - The range of temperature over which a SENSOR is compensated to maintain span and zero balance within specified limits.

**Complementary Circuit** - A circuit that provides push-pull operation (sink and source capability) with a single input.

**Complementary Metal Oxide Semiconductor (CMOS)** - A semiconductor process where both P and N channel enhancement model field effect transistors are fabricated compatibly on a silicon or sapphire substrate.

**Conductance** - The reciprocal of resistance.

**Conductive Level Detector** - A device with single or multiple probes. A change in level completes an electric circuit between the container and/or probes.

**Conductor** - A substance or body that allows a current of electricity to pass continuously along it.

**Converter** - A device that receives information from a SENSOR or sensor, alters the form of the information, and sends out a resultant output signal.

**Coulomb** - The SI (Système International d'Unités) unit of electric charge.

**Curie Temperature** - The temperature at which the properties of a material change from being ferromagnetic to paramagnetic on heating (vice versa on cooling).

**Current** - The time value of movement of free electrons. One ampere = 1 coulomb/second. Conventional reference is opposite to the direction of actual electron movement.

**Current Mode Logic (CML)** - Logic in which sensors operate in the unsaturated mode as distinguished from most other logic types that operate in the saturation region. This logic has very fast switching speeds and low logic swings.

**Current Sinking** - A transistor configuration where loads are normally connected between the output and a supply voltage. When the transistor is ON, current flow is from the load into the transistor.

**Current Sourcing** - A transistor configuration where loads are normally connected between the output and ground. When the transistor is ON, current flow is from the transistor into the load.

## - D -

**DC** - See Direct Current.

## Glossary

---

**Dead Band** - The range through which an input can be varied without initiating response. Dead band is usually expressed in percent of span or engineering units.

**Demagnetization** - The partial or complete reduction of flux density.

**Demagnetization Curve** - A portion of the magnetization curve (second quadrant) for a magnetic material showing the manner in which the residual induction and the magnetization reduces to zero. This curve describes the characteristics of a permanent magnet (as contrasted with an electromagnet).

**Demagnetizing Field,  $H_d$**  - A magnetizing force applied in such a direction as to reduce the remanent induction in a magnetized body.

**Deviation** - The departure from a desired value.

**Diamagnetic Material** - A material having permeability less than that of a vacuum. For practical evaluation, a non-magnetic material.

**Diaphragm** - A pressure sensing device in which pressure is applied to either or both sides of a flexible enclosed membrane. Diaphragm movement is a measure of pressure or differential pressure or force.

**Differential (Hall effect sensor)** - The difference between the operate and release values of a Hall effect sensor. See Hysteresis.

**Differential Amplifier** - An amplifier whose output is proportional to the difference between the voltages applied to its two inputs. Also called a difference amplifier.

**Digital Circuit** - A circuit that has only two stable states, i.e., it is either ON or OFF, HIGH or LOW (high voltage or low voltage).

**Digital Hall Effect Sensor** - See Hall Effect Sensor, Digital.

**Dimension Ratio,  $L/D$**  - The ratio of the length of a magnet in the direction of magnetization to diameter. Or, the ratio of the length of the magnet to the diameter of a circle having an area equal to the cross-sectional area of the magnet. Used as a figure of merit to find the magnet's composite permeance coefficient.

**Diode** - A semiconductor device having two terminals and exhibiting a nonlinear voltage-current characteristics; a semiconductor device that has the asymmetrical voltage-current characteristic exemplified by a single P-N junction. Conducts current much more readily in one direction than the other.

**Direct Current (DC)** - An unidirectional current where the changes in value are zero or so small that they may be neglected.

**Discrete Circuits** - Electronic circuits built of separate components (transistors, resistors, etc.) connected by wiring or printed circuit etched conductors.

**Domain** - The region within a ferromagnetic substance where the magnetic fields of many atoms tend to orient themselves parallel to each other.

**Drift** - An undesired change in output over a period of time. The change is unrelated to input, operating conditions, or load.

**Dynamic Behavior** - Behavior as a function of time.

## - E -

**ECKO** - See Eddy Current Killed Oscillator.

**ECL** - See Emitter Coupled Logic.

**Eddy Current Killed Oscillator** - A sensor operated on the principle that changing the reactance of the tank circuit of an oscillator enough to stop the oscillations, which trigger the output.



**Eddy Current Loss,  $P_e$**  - That portion of the core loss due to the current circulating in the magnetic material as a result of electromotive forces induced by varying induction.

**Eddy Currents** - Those currents induced in the body of a conducting mass or coil by a rate of change in magnetic flux.

**Electromotive Force (EMF)** - See Voltage.

**Electron** - A negative charged particle with an electrical charge equal to about  $1.6 \times 10^{-19}$  coulomb.

**Emitter Coupled Logic** - A bipolar IC logic family characterized by its very high speed, low circuit density, and high power dissipation.

**Emitter Follower** - A transistor amplifier circuit characterized by relatively high input impedance, low output impedance, and a voltage gain of less than one.

**Energy Product Curve (magnetic)** - The graphical representation of the energy per unit volume produced by a magnet derived from the product of the flux density and demagnetizing field.

**Equilibrium** - The condition of a system when all inputs and outputs have steadied down and are in balance.

**Error** - The difference between the actual and the true value.

## - F -

**Fall Time** - A measure of the time required for the output voltage of a circuit to change from a high voltage level to a low voltage level, once a level change has started.

**Fan-Out** - The number of standard loads in a logic family that can be driven by a circuit output. A standard load is the current required to switch the basic gate of the family.

**Ferromagnetic Material** - Substances showing magnetic properties similar to those of iron; e.g. high magnetic susceptibility, permanent magnetism, etc. They include among the pure elements nickel, and cobalt and in addition, many alloys.

**Ferrous** - Composed of or containing iron. A ferrous metal exhibits magnetic characteristics.

**FET** - See Field Effect Transistor.

**Field Effect Transistor** - A transistor controlled by voltage rather than current. The flow of a current through a semiconductor channel is regulated by the effect of an electric field.

**Flip-Flop** - A type of digital circuit whose output can be in either of two static states depending both on the input received and on the previous state of the output.

**Floating Ground** - See Ground, Floating.

**Fluidic Flow Meter** - A flow meter based on the Coanda effect of the tendency of a fluid stream to attach itself to a nearby wall.

**Flux (magnetic)  $\Phi$**  - The magnetic lines of force produced by a magnet.

**Flux Concentrator** - A piece of soft, ferromagnetic material used to focus lines of flux in a given area.

**Flux Density (magnetic)  $B$**  - The magnetic flux passing through a unit area of a magnetic field in a direction at right angles to the magnetic force. Also called magnetic induction.

**Frequency** - The number of complete alternations per second of an alternating current.

## Glossary

---

### - G -

**Gap** - 1. A break in a closed magnetic circuit, containing air or filled with a non-magnetic material. 2. The distance between a permanent magnet and a Hall effect sensor when they are in closest proximity.

**Gauss** - The CGS unit of magnetic induction or flux density. 1 Gauss = 1 maxwell/sq. cm.

**Gilbert** - The CGS unit of magnetomotive force. The magnetomotive force required to produce one maxwell magnetic flux in a magnetic circuit of one unit of reluctance.

**Ground, Electrical** - A conducting path, intentional or accidental, between an electric circuit or equipment and the earth, or some large conducting body serving in place of the earth (a voltage reference).

**Ground, Floating** - A reference point or voltage in a circuit that is not tied to an external ground.

### - H -

**Hall Effect** - The development of a voltage between the two edges of a current carrying conductor whose faces are perpendicular to a magnetic field.

**Hall Effect Sensor** - A device that converts the energy stored in a magnetic field to an electrical signal by means of the Hall effect.

**Hall Effect Sensor, Digital** - A device that converts the energy stored in a magnetic field to an electrical signal which is always in one or two stable states (ON or OFF, High or Low, 1 or 0).

**Hall Effect Sensor, Linear** - A device that converts the energy stored in a magnetic field to a voltage which is directly proportional to its input.

**Hall Element** - The basic component of a Hall effect sensor that converts magnetic field to a lower level electrical signal. When used alone is often referred to as a Hall effect generator.

**Hall Sensor** - A term sometimes used to describe a SENSOR based upon a Hall effect sensor.

**Hard, Magnetically** - A ferromagnetic material having a high coercive force and high residual induction. Used to designate a permanent type magnetic material and not always synonymous with hardmetallurgically.

**Henry** - MKS unit of inductance. Equal to the self-inductance of a circuit or the mutual inductance of two circuits. The variation of 1 ampere/second results in an induced electromotive force of 1 volt.

**High Threshold Logic** - Allows for higher degree of inherent electrical noise immunity. A considerably larger input threshold characteristic is exhibited by the HTL devices by using a reverse biased base-emitter junction that operates in the breakdown avalanche mode. A higher input signal is required to turn on the HTL output inverting transistor than the DTL.

**HTL** - See High Threshold Logic.

**Hydroscopic Material** - A material with great affinity for moisture.

**Hygrometer** - A device that measures humidity.

**Hysteresis (magnetic)** - The difference between the magnetization that results from an increasing or decreasing magnetizing force.

**Hysteresis (switching)** - The difference between the point where a digital state change occurs (ON to OFF, OFF to ON) for an increasing or decreasing input. In a Hall effect sensor, this results in a distinct operate and release point.

**Hysteresis Loss,  $P_h$**  - The power dissipated in a ferromagnetic core as a result of its hysteresis; proportional to the product of the area of the loop times the frequency times the volume of the core.

---

**- I -**

**IC** - See Integrated Circuit.

**I<sup>2</sup>L** - See Integrated-Injection Logic.

**Impedance** - Ratio of electromotive force to effective current.

**Indox** - The trade name of Indiana General magnet product's barium ferrite permanent magnet alloy.

**Inductance** - The property of an electric circuit where an electromotive force is induced in it by a variation of current either in the circuit itself or in a neighboring circuit.

**Inductance (magnetic)** - See Flux Density.

**Inductance, Residual, B<sub>r</sub>** - See Residual Induction.

**Inductive Level Detector** - A level measuring system incorporating an oscillator and electromagnetic field.

**Input** - In electronic usage input usually means the signal or stimulus put into a circuit to make the output do something. For example: in an audio amplifier the input is not the 120 VAC power supply. The input is the signal from the magnetic head or whatever picks up the signal.

**Integrated Circuit** - An interconnected array of active and passive elements integrated within a single semiconductor substrate and capable of performing one complete electronic circuit function.

**Integrated-Injection Logic** - A bipolar logic design. ICs with a circuit density approaching MOS and the speed of the TTL.

**Interface Circuit** - A circuit that links one type of logic family with another or with analog circuitry. Its function is to produce the required current and voltage levels for the next stage of circuitry from the previous stage.

**Interference (electrical)** - Any spurious voltage or current arising from external sources and appearing in the circuits of a device.

**Interference, Electrostatic Field** - A form of interference induced in the circuits of a device due to the presence of an electrostatic field. It may appear as a common mode or normal mode interference in the measuring circuits.

**Interference, Magnetic Field** - A form of interference induced in the circuits of a device due to the presence of a magnetic field. It may appear as common mode or normal mode interference in the measuring circuits.

**Inverter** - A circuit whose output is always in the opposite state (phase) from the input. This is also called a NOT circuit. (A teeter-totter is a mechanical inverter).

**Isotropic, Magnetic** - A material having the same mechanical characteristics along any axis or orientation. Might be considered as the antonym of anisotropic.

**- K -**

**Keeper** - A piece of magnetically soft material used to close the magnet-circuit of a permanent magnet in order to protect it again demagnetizing influences.

**- L -**

**Latching Output** - Signal modification that maintains a digital output state after an input has been removed.

**Leakage Current** - An undesirable small value of current that flows thru (or across) the surface of an insulator, the dielectric of a capacitor, or a reverse-biased P-N junction.

## Glossary

---

**Least Squares Fit** - A linear approximation to a curve where a straight line is chosen to minimize the sum of the squares of the deviation between the straight line and the curve.

**LED** - See Light Emitting Diode.

**Level Detector** - See Comparator.

**Light Emitting Diode (LED)** - A solid state device that emits visible and/or infrared light when excited by a current.

**Linear Circuit** - A circuit with the property that its output is proportional to its input.

**Linear Hall Effect Sensor** - See Hall Effect Sensor, Linear.

**Linear Variable Differential Transformer (LVDT)** - A mutual inductance sensing element. It produces electrical output proportional to the movement of a separate movable core. Also available in a rotary version (RVDT).

**Linearity** - The measure of the deviation of a curve from a straight line.

**Load Line** - The line used to locate the operating point of the permanent magnet on the demagnetization curve. The slope of this line is equal to the permeance coefficient.

**Lodex** - A Hitachi trade name for permanent magnets that consist of elongated, single-domain iron cobalt particles dispersed in a lead matrix.

**Logic** - See Digital.

**LOHET (Linear Output Hall Effect Sensor)** - A linear output Hall effect sensor integrated circuit. A MICRO SWITCH acronym.

**Low Energy Materials** - Ferromagnetic materials having a low energy product; usually a low coercive force and residual induction and therefore, easily demagnetized. Also know as soft magnetic materials.

### - M -

**Magnet** - Any piece of material that produces a magnetic field and thus attracts materials such as iron.

**Magnet, Ring** - A cylindrical magnet around whose circumference pole pairs are magnetized.

**Magnetic Circuit** - Magnets combined with any soft ferromagnetic materials (pole pieces, flux concentrators, vanes, etc.) that make up closed paths for lines of flux.

**Magnetic Field** - A condition of space surrounding a magnetic pole or conductor, through which current is passing, which accounts for the physical force exerted by a magnet.

**Magnetic Field Intensity** - See Flux Density.

**Magnetic Field Strength, H** - The magnetomotive force per unit length at any given point in the magnetic circuit. At the CGS system, the unit is oersted.

**Magnetic Meter** - A flow meter based on Faraday's Law of Magnetic Induction. A conductive fluid flowing at right angles to a magnetic field will have a voltage introduced into it that is proportional to the relative velocity of the conductor and the field.

**Magnetic Moment** - On an atomic level, the force that results in the orientation of the magnetic field of an individual atom.

**Magnetic System** - A description of a magnetic circuit and the manner in which the magnetic field in the circuit varies as a function of time or motion at a point being considered (reference point).

**Magnetization Curve** - A curve showing successive states during magnetization of a ferromagnetic material. Flux density (B) is plotted against magnetizing field (H).

**Magnetomotive Force (mmf)** - The force that produces a magnetic field, either by current flowing through a conductor or by the proximity of a magnetized body.

**Magnetoresistor** - A semiconductor device in which the electrical resistance is a function of the applied magnetic field.

**Magnetostriction** - The phenomenon that ferromagnetic material show a small deformation under the influence of a magnetic field and, conversely, the magnetic properties are affected when the materials are strained mechanically.

**Mass Flow Meter** - A meter that measures flow in terms of mass rather than volume.

**Maxwell** - The CGS unit of magnetic flux. 1 maxwell =  $10^{-8}$  webers

**Metal Oxide Semiconductor (MOS)** - A class of insulated gate field effect transistors (FETs). The gate is insulated from the semiconductor substrate material by using an oxide (or nitride) dielectric to form a unipolar device.

**MKS** - Meter, kilogram, second system units of measure.

**Mode (magnetic)** - A description of the type or motion of a magnetic system.

## - N -

**NI (ampere turns)** - The product of the number of turns of a coil or a winding (distributed or concentrated) and the current in amperes circulating in the turns.

**Normally High** - The state of a device where the output is high (Logic 1) when no actuation forces are exerted.

**Normally Low** - The state of a device where the output is low (Logic 0) when no actuation forces are exerted.

**North Pole** - In a magnet, the pole where magnetic lines of force are considered to leave the magnet. The pole that points to geographic north for a freely suspended magnet.

**NPN (transistor)** - A transistor consisting of two N-type regions separated by a P-type region.

**N-Type** - Mobile conduction electron concentration exceeds hole concentration.

**Nuclear (radiation) Sensor** - A device consisting of a radiation source and a detector. Used to measure level, density, flow and mass flow.

**Null Offset** - The output from a device that results from a null or zero level input.

## - O -

**Oersted** - the CGS unit of magnetizing field, 1oersted = 2.021 ampere-turns/inch =  $10^3/4\pi$  NI/meter.

**Offset** - The change in input voltage required to produce a zero output voltage in a linear amplifier circuit.

**Off State Current** - See Leakage Current.

**Ohm** - The unit of electrical resistance. It is the resistance through which a current on one ampere will flow when a voltage of one volt is applied.

**Ohm's Law** - The current [I] in a circuit is directly proportional to the total voltage [E] in the circuit and inversely proportional to the total resistance [R] of the circuit. The law may be expressed in three forms:  $E=IR$ ;  $I=E/R$ ;  $R=E/I$ . Elements that obey Ohm's Law are called linear resistors.

**ON Voltage** - The voltage with respect to ground or the minus supply at a sensor output when it is in the conducting or ON state.

**One Shot** - A logic device whose output is a pulse triggered by an input and is of a fixed duration.

## Glossary

---

**Operational Amplifier** - A stable, high gain, direct coupled amplifier that depends on external feedback to determine its functional characteristics.

**Optoelectronics** - Technology dealing with the coupling of functional electronic blocks by light beams.

### - P -

**Parallel Circuit** - A circuit in which the current has two or more paths to follow. Two electrical elements are in parallel if (and only if) both terminals of both elements are electrically connected.

**Paramagnetic Material** - Material having a permeability slightly greater than that of a vacuum; generally considered non-magnetic.

**Passive Elements** - Resistors, inductors, capacitors, transformers, or diodes... elements incapable of power gain.

**Peak Energy Product** - The peak value of the product of the magnetic flux density (B) and the magnetizing field (H). Used as an index of magnetic material performance.

**Permanent Magnet Material** - A piece of ferromagnetic material which once having been magnetized shows definite resistance to external demagnetizing forces, i.e., it requires a high demagnetizing force to remove the resultant magnetism.

**Permeability ( $\mu$ )** - A measure of how much better a given material is than a vacuum as a path for magnetic lines of flux. Permeability is the flux density, B (gauss) divided by the magnetizing force, H (øersted).

**Permeability, Differential ( $\mu_D$ )** - The slope of the normal induction curve.

**Permeability, Incremental ( $\mu_{\Delta}$ )** - The ratio of the cyclic change in magnetic induction to the corresponding cyclic change in magnetizing force when the mean induction differs from zero. For small changes in magnetizing force, the incremental permeability is approximately equal to the slope of the minor hysteresis loop generated.

**Permeability, Initial ( $\mu_0$ )** - The slope of the normal induction curve at zero magnetizing force.

**Permeability, Intrinsic ( $\mu_i$ )** - The ratio of intrinsic normal induction to the corresponding magnetizing force.

**Permeability, Normal ( $\mu_N$ )** - The ratio of normal induction to a corresponding magnetizing force.

**Permeability, Relative (sometimes designated  $\mu_R$ )** - The permeability of a body relative to that of a vacuum.

**Permeability, Reversible (swing back permeability  $\mu_r$ )** - The slope of hysteresis loop at the residual induction. For a permanent magnet, when the induction is increased, the operating point ( $B_d$ ,  $H_d$ ) does not return along the demagnetization curve but moves along a line having the slope.

**Permeability, Space ( $\mu_V$ )** - The factor that expresses the ratio of magnetic induction to the magnetizing force in a vacuum. In the CGS system, the permeability of a vacuum is one.

**Permeance (P)** - A characteristic of a magnetic circuit equal to magnetic flux divided by a magnetomotive force.

**Permeance Coefficient (demagnetizing coefficient) (B/H)** - Describes the operating conditions of the magnet and is the slope of the magnetic load line.

Equal to  $B/H = L_m/A_m \times P$ . Where  $L_m$  and  $A_m$  are the length and the area of the magnet respectively, and P is the permeance from one end of the magnet to the other.

**Photocell** - A resistive, bulk effect type of photosensor; used when it is desirable to wire several photoreceivers in series or in parallel.

**Photo Optics** - The combination of an input light source and a photoreceiver producing an output signal and assembled either separately or in a single package.

**Photoreceiver** - A unit consisting of a photosensor, focusing lens, and protective enclosure.

**Photosensor** - A light-sensitive device in a photoelectric control that converts a light signal into an electric signal.

**Phototransistor** - A type of transistor whose output is controlled by the light intensity on its surface.

**Piezoelectric** - The property of certain crystals that produce a voltage when subjected to mechanical stress, or undergo mechanical stress when subjected to a voltage.

**Piezoresistance** - Resistance that changes with pressure.

**P-MOS, P Channel MOS** - Pertaining to MOS devices made on N-type substrates in which the active carriers flow between P-type source and drain contacts. The N-type channel inverts to P-type at the surface with the application of the proper voltage to the gate terminal.

**P-N Junction** - A region of transition between P-type and N-type semiconducting material.

**PNP (transistor)** - A transistor consisting of two P-type regions separated by an N-type region.

**Pole Face** - That surface of a magnet where lines of flux radiate or terminate (either a north or south pole).

**Pole Pair** - A combination of north and south poles. Multiple pole magnets must have an equal number of north and south poles and are, therefore, specified in terms of pole pairs.

**Pole Piece** - One or more pieces of soft ferromagnetic material used to channel or direct lines of flux.

**Poles, Magnetic** - Those portions of the magnet where the lines of flux converge. All magnets have at least two poles, north and south.

**Potentiometer** - A variable resistor used in an electronic bridge circuit. Commonly used to measure temperature or pressure.

**P-Type** - Mobile hole concentration exceeds the conduction electron concentration.

**Power Consumption** - The maximum wattage used by a device within its operating range during steady-state signal condition.

**Pull-down Resistor** - A resistor connected across the output of a device or circuit to hold the output equal to or less than the 0 input level. Also used to lower the output impedance of digital or analog devices. It is usually connected to a negative voltage or ground.

**Pull-up Resistor** - A resistor connected across the output of device or circuit to hold the output voltage equal to or greater than the 1 input level. It is usually connected to a positive voltage.

**Pulse** - A momentary sharp change in current, voltage or other quantity that is normally constant. A pulse is characterized by a rise and fall, and has a finite duration.

**Pyrometer** - A class of temperature measuring instruments incorporating a SENSOR and a readout device.

## - R -

**Radiation Pyrometer** - A temperature measuring device that uses an optical system to focus radiant energy from an object onto a detector. The detector converts this energy into an electrical signal that varies with the temperature of the object.

**Reactance** - The part of the impedance of an alternating current circuit that is due to capacitance or inductance or both. Expressed in ohms.

**Regulator (voltage)** - A device used to maintain a desired output voltage regardless of normal changes to the input or to the output load.

**Reliability (of a sensor)** - A measure of the probability that a sensor will continue to perform within specified limits for a given length of time under specified conditions.

**Reluctance [R]** - The resistance of a magnetic path to the flow of the magnetic lines of force through it. It is the reciprocal of permeance and is equal to the magnetomotive force divided by the magnetic flux.

## Glossary

---

**Remanence (see residual induction) ( $B_d$ )** - The magnetic induction that remains in a magnetic circuit after the removal of the applied magnetomotive force. If there is an air gap in the magnetic circuit, the remanence will be less than the residual induction. For a permanent magnet, the remanence can be considered as the operating induction. Note: The European definitions of residual induction and remanence are interchanged.

**Repeatability** - The ability of a device to reproduce output readings when the same measurand value is applied to it consecutively in the same direction.

**Reproducibility** - The exactness with which a measurement or other condition can be duplicated over a period of time.

**Residual Induction ( $B_r$ )** - The flux density corresponding to a zero magnetizing field in a magnetic material under the conditions it has been fully magnetized and contained in a closed magnetic circuit with no air gap. See Remanence.

**Resistance** - The opposition that a device offers to the flow of electrical current. All substances have the quality of electrical resistance. Copper has very low resistance and glass has very high resistance. Resistors are parts used in electronic circuits, which when connected between terminals of a battery or power supply, allow a predictable quantity of current to flow. Resistance is measured in ohms.

**Resistance Temperature Detector (RTD)** - A device whose resistance changes as a function of its temperature.

**Resolution** - The degree that nearly equal values of a quantity can be discriminated by a system or device.

**Resonant Wire** - A SENSOR based on the resonant frequency of a vibrating wire which changes as strain is applied to it.

**Response** - The behavior of the output of a device as a function of the input, both with respect to time.

**Response Time** - The time it takes for a device to respond to an input signal.

**Ring Magnet** - See Magnet, Ring.

**Rise Time** - A measure (10% to 90%) of the time required for the output voltage to rise from a state of low voltage level to a high voltage level, once a level change has been started.

## - S -

**Saturation, Magnetic** - The condition where all domains have become oriented in one direction. A magnetic material is saturated when an increase in the applied magnetizing field produces no appreciable increase in intrinsic induction.

**Saturation Voltage** - 1. The voltage drop appearing across a switching transistor (collector-emitter) when it is turned ON. 2. The voltage between base and emitter required to cause collector current saturation.

**SCR** - See Silicon Controlled Rectifier.

**Semiconductor** - A material whose resistivity is between that of conductors and insulators, and whose resistivity can sometimes be changed by light, an electric field or a magnetic field.

**Sensing device** - Any device that detects, measures, and responds to a physical quantity. Examples of various types are: current sensors, audio sensors, and light sensors.

**Sensing Element** - The basic component of a sensor that changes a physical quantity into an electrical signal.

**Sensitivity** - 1. (Linear Sensor) The proportionality constant that related the output of a sensor to its input. 2. (Digital Sensor) The magnitude of a maximum field required to actuate a digital Hall effect sensor.

**Sensor** - The primary component of any sensing device. A sensor detects one form of energy and converts it to another. The energy detected may be magnetic, electrical, mechanical, acoustical, etc. Examples of various types of sensors are Hall effect, variable reluctance, optoelectronic, piezoresistive and variable capacitance.

**Series Circuit** - A circuit in which the current has only one path to follow.

**SI** - "Le Systeme International d'Unités." Standard international unit. Same as MKS system-meter, kilogram, second.



**Signal Conditioning** - To process the form or mode of a signal so as to make it intelligible to, or compatible with, a given device, including such manipulation as pulse shaping, pulse clipping, digitizing and linearizing.

**Silicon Controlled Rectifier (SCR)** - A three-junction semiconductor device that is normally an open circuit until an appropriate signal is applied to the gate terminal, at which time it rapidly switches to the conducting state. Its operation is such that it only conducts current in one direction.

**Sink** - See Current Sinking.

**Sintering** - The process of bonding metal or other powders by cold-pressing into the desired shape, then heating to form a strong cohesive unit.

**Snap Action** - A rapid motion of contacts from one position to another position or their return. (Differential storing of energy).

**Soft, Magnetically** - A ferromagnetic material having a low coercive force. Used to designate materials for electromagnets, pole pieces, flux concentrators and vanes. Not always synonymous with softmetallurgically.

**Solid State Switch** - A no-contact device that completes a circuit by means of solid state components.

**Sonic Sensor** - A device using a sonic signal to measure level or flow.

**Source** - See Current Sourcing.

**South Pole** - In a magnet, the pole where magnetic lines of force are assumed to enter after emerging from the north pole.

**Span** - Defines the output range of a linear output sensor. Span is the difference in output voltages when the input is varied from a minimum gauss to a maximum gauss.

**Stabilization** - The treatment of a permanent magnet material designed to increase the permeance of its magnetic properties. This process may include such conditions as heat, shock or demagnetizing fields so that the magnet will produce a constant magnetic field. Stabilization generally refers only to magnetic stability wherein if the disturbing influence were removed and the magnet remagnetized, any magnetic changes can be completely restored. Flux changes caused by internal structural changes are permanent in character and cannot be restored simply by remagnetization.

**Strain Gage** - A device whose resistance changes as it is subjected to strain.

**Substrate** - The material upon or within which an integrated circuit or transistor is formed.

**Susceptibility** - The ratio of the intensity of magnetization produced in a substance, to the magnetizing force or intensity of the field to which it is subjected.

## - T -

**Tesla** - The MKS unit of magnetic induction. Equal to 1 weber per square meter.

**Thermistor** - An electrical resistor whose resistance varies sharply with temperature.

**Thermocouple** - A device constructed of two dissimilar metals that generates a small voltage as a function of the temperature difference between a measuring and reference junction.

**Thompson Effect** - The principle in which a voltage is developed in a conductor that is subjected to a longitudinal temperature gradient (temperature difference between two points along its length). Discovered by William Thompson (Lord Kelvin).

**Thyristor** - Any of several types of transistors having four semi-conducting layers (three P-N junctions). The solid state analogue of the thyatron. See SCR.

**Sensor** - Any device that converts energy from one form to another. The energy may be magnetic, electrical, mechanical, acoustical, etc. Examples of various types of sensors are Hall effect, variable reluctance, optoelectronic, piezoresistive and variable capacitance.

## Glossary

---

**Transients** - In electrical usage, usually refers to an unwanted, temporary, large increase or decrease in a current or supply voltage that only occurs occasionally. Usually due to reactive components during rapid changes in a voltage or a current.

**Transistor** - A tiny chip of crystalline material, usually silicon, that amplifies or switches electric current. It is a three terminal semi-conductor device. A small current (base current) applied to one terminal causes a larger current (collector current) to flow between the other two terminals. For elementary purposes, you can look at a transistor as a resistor whose value can be changed from a high to a low value by applying a current to the base lead.

**Transistor-Transistor Logic** - A bipolar circuit logic family where the multiple inputs on gates are provided by multiple emitter transistors. This family is characterized by high speed and low cost, and is widely used in modern digital circuits.

**Triac** - A General Electric trade name for a gate-controlled full-wave AC silicon switch. Designed to switch from a blocking state to a conducting state for either polarity of applied voltage with positive or negative gate triggering.

**Trigger** - A timing pulse used to initiate the transmission of signals throughout the appropriate circuit signal paths.

**TTL, T<sup>2</sup>L** - See Transistor-Transistor Logic.

### - U -

**Ultrasonic Sensor** - A device using an ultrasonic signal to measure level or flow.

**Ultrasonics** - The technology involved with sounds that are too high in frequency to be heard by the human ear.

**Uniform Field** - A magnetic field where the magnitude and direction are constant in the region being considered at any instant.

**Unipolar Magnetic System** - A magnetic system where the direction of the magnetic field, at the point being considered, has a single polarity (plus or minus) over time or motion of the system.

**Unipolar Sensor (Hall effect)** - A sensor whose maximum operate and minimum release value have a positive gauss level. A gauss level is considered positive if its direction is the same as the reference direction of the sensor.

### - V -

**Vane** - A piece of soft ferromagnetic material used to shunt lines of flux away from a given area.

**Vibration Level Detector** - A level detector based on the fact that when a vibrating element comes in contact with a different medium, its vibrating frequency changes or stops.

**Volt** - The unit of voltage, potential and electromotive force. One volt will send a current of one ampere through a resistance of one ohm.

**Voltage** - Term used to designate electrical energy difference that exists between two points and is capable of producing a flow of current when a closed circuit is connected between the two points.

**Voltage Drop** - The voltage developed across a component or conductor by the flow of current through the resistance or impedance of that component or conductor.

**Vortex Precession Flow Meter** - A flow meter based on vortex precession. Fluid entering the meter is forced to rotate as it passes through a set of fixed turbine-like blades. As the rotating fluid leaves the vanes, its center or vortex takes on a helical path. This change is called precession. The frequency of precession is proportional to the volumetric flow.

**Vortex Shedding** - The phenomena that a bluff body inserted in a flow causes alternative vortices to be created in the fluid on the downstream side. The frequency of the appearances of these vortices becomes a measure of the flow rate.

**- W -**

**Weber** - The MKS unit of magnetic flux. The amount of magnetic flux which, when linked at a uniform rate with a single turn electrical circuit during an interval of one second, will produce in this circuit an electromotive force of one volt.

**Wiegand Effect** - Under the influence of a magnetic field, domain reversals occur in a specially processed ferrous wire, generating a voltage pulse.

**Wired-OR** - The connection of two or more open collector or sinking outputs to a common point. The combined output is a Logic 0 if any of the individual outputs is 0 and a Logic 1 if all of the individual outputs are 1.

# Index

## -A-

Absolute maximum ratings.....	20, 30
Adjustable current sensor.....	65
Adverse fields .....	83
Air gap.....	15, 39, 43
Alnico .....	80
Analog linearization.....	65
Analog output sensors.....	5, 6, 29, 30
Analog .....	19, 66
Anti-skid sensor .....	67
Automotive sensors.....	76

## -B-

Basic interfaces.....	21, 30
Bias magnets.....	16, 42
Bipolar slide-by mode.....	13
Bipolar .....	17
Bohr's Model.....	79
BR .....	29
Brushless DC motor sensors.....	69

## -C-

Cam-operated vane sensors.....	63
Circuit chips.....	19
Circular vane.....	36
Closed loop current sensors.....	39, 40
Coercive force.....	10
Coil.....	39, 40
Conversion factors .....	77
Crankshaft position sensor .....	68
Current sensor .....	37, 38, 71

## -D-

Demagnetization curve.....	10
Design symbols .....	24
Device design .....	45
Differential travel.....	42
Digital current sensors .....	36
Digital output current sensors.....	59
Digital output sensors.....	7, 19, 29, 37
Digital .....	17, 19
Discrete capacitors.....	42
Discrete sensing devices .....	48
Distributor mounted ignition sensor .....	68
Door interlock sensor .....	67

## -E-

Electrical characteristics .....	21
Electrical quantities.....	78
Electrical specifications.....	20, 30
Electromagnets.....	37
EMI.....	49
Energy product curve.....	10

## -F-

Feedback system.....	40
Ferrous vane sensor .....	34
Field strength factors .....	11
Flow rate sensor .....	63, 72
Flux concentrator .....	15

## -G-

Gauss.....	9, 13, 18, 52
Gear tooth sensors .....	42, 44

## -H-

Hall effect sensor .....	10, 12, 18, 28, 33, 37, 39, 40
Hall effect .....	1, 2, 3, 4, 9, 19, 21, 45, 47
Hall element .....	4
Hall voltage.....	3, 4
Hall, Edwin .....	3
Head-on mode.....	89

## -I-

IC .....	38
Indox .....	81
Input characteristics.....	8
Interfaces.....	31

## -K-

Kelvin .....	3
--------------	---

# Index

<b>-L-</b>	
Level/tilt measurement sensor.....	69
Linear current sensors .....	38, 55
Linear feedback sensor .....	66
Linear output sensors.....	53, 65, 73
Linear .....	17
Locked-in domains.....	80
Lodex.....	81
Logic gate interfaces.....	22
Logic level sensor .....	59
Lorentz force.....	3
Low-level current sensor .....	72
<b>-M-</b>	
Magnetic card reader .....	74
Magnetic characteristics.....	9
Magnetic circuit.....	33
Magnetic curve .....	55, 58, 89
Magnetic flux .....	15, 20, 40
Magnetic materials.....	9
Magnetic quantities .....	77
Magnetic systems .....	11, 17
Magnetism.....	79
Material characteristics .....	80
Maximum current.....	41
Mechanical characteristics .....	35
Mechanically operated solid state switches.....	41
Metalurgical.....	82
Microprocessor controlled sensor.....	67
Microprocessor linearization.....	65
Motion type.....	17
Multiple position sensor.....	66
Multiple tooth vane sensor .....	34, 35
Multiples of units.....	78
<b>-N-</b>	
Non-precision applications .....	49, 50
NPN.....	19, 20, 22, 49
Null offset .....	31
<b>-O-</b>	
Office machine sensors.....	64
Operating force.....	42
Operating point.....	42, 43
Operational amplifier.....	39
Optoelectronic .....	46
Output characteristics .....	8
Output current.....	20, 21, 40
Output leakage current.....	21
Output switching time .....	21
Output voltage .....	21
Output vs. power supply characteristics .....	5
Over-travel.....	42
<b>-P-</b>	
Paper detection sensor .....	64
Peak Energy Product .....	10
Phototransistor .....	46
Piezoresistance effect.....	4
Piston detection sensor.....	73
Plunger.....	41
PNP .....	49
Pole pieces.....	15, 33
Power supply characteristics.....	8
Precision applications .....	51
Precision .....	17
Pressure sensor.....	73
Pre-travel.....	42
Primary current.....	40
Principles of operation .....	37, 38, 39, 41, 43
Proximity sensors .....	64
Pull-up resistors.....	21
<b>-R-</b>	
Radiation.....	83
Radiometric analog sensor .....	6
Rail to rail operation .....	18
Rare earth magnet.....	16
Rare earth .....	81
Ratiometric linear hall effect sensors.....	18
Reluctance changes .....	83
Remote conveyor sensing.....	70
Remote reading sensor.....	71
Residual induction .....	10
Reverse orientation.....	16
Ring Magnet.....	14, 46, 63
Rotary mode.....	96
RPM sensors .....	70
<b>-S-</b>	
Sensitivity shift .....	39
Sensor packages .....	57
Sensor specifications.....	35, 37
Sequencing sensors .....	63
Signature pulse.....	44
Sinking output .....	23
Sinking sensor.....	22, 25, 26, 27, 28
Slide-by mode .....	92
Slope.....	17, 53
Solid state switches .....	41, 42
Sourcing output .....	22
Speed sensor .....	68
Supply current .....	21
Supply voltage.....	21
Symmetry.....	17
System definition.....	48

**-T-**

Target design.....	43
Target geometry.....	44
Target speed.....	43, 44
Temperature coefficient.....	18
Temperature sensor.....	46
Temperature sensor.....	73
Throttle angle sensor.....	75
Toroid core.....	97
Total magnetic flux.....	39
Transfer function.....	6, 7
Transistor interfaces.....	22
Transmission mounted speed sensor.....	68
TTL.....	22
Two-wire current loop.....	28

**-U-**

Uniform tooth and window.....	36
Unipolar head-on mode.....	12, 16
Unipolar slide-by mode.....	12
Unipolar.....	17
Units.....	77
Unmagnetized magnets.....	84

**-V-**

Vane sensor.....	71
Vane-operated linear sensor.....	36
Vane-operated position sensors.....	33, 34
Vane-operated sensors.....	58
Voltage output.....	40

**-W-**

Wide slot.....	44
Wired OR.....	28



**Honeywell**

---

**Sensing and Control**  
Honeywell Inc.  
11 West Spring Street  
Freeport, Illinois 61032



Printed with Soy Ink  
on 50% Recycled Paper

[www.honeywell.com/sensing](http://www.honeywell.com/sensing)